

BoaX2[™] 2000

Powered by EXM2

Model 7451X2 Monitor

Installation, Operating, & Maintenance Instructions



98638000 REV-REL

1-574-295-8330
www.elkhartbrass.com

ELKHART BRASS
FIRE FIGHTING EQUIPMENT A SAFE FLEET BRAND

CONTENTS

- PRODUCT SAFETY INFORMATION 3**
- MONITOR CALLOUT DRAWING 4**
- SYSTEM COMPONENTS 5**
- CONTROL 7**
- MONITOR & VALVE ACCESSORIES 8**
- INSTALLATION INSTRUCTIONS 8**
 - Installation Step 1: Mount and Wire all System Components 9
 - Installation Step 2: Configure the EXM System 18
 - Installation Step 3: Calibrate the EXM2 System 18
 - Installation Step 4: Final Check 20
- OPERATING INSTRUCTIONS 21**
- MAINTENANCE INSTRUCTIONS 30**
- TROUBLESHOOTING GUIDE 31**
- SYSTEM SPECIFICATIONS 33**
- OPTIONAL ACCESSORY SPECIFICATIONS 34**

To view the most current parts list, drawings, or demonstrations of common EXM commands, please visit www.elkhartbrass.com

PRODUCT SAFETY INFORMATION

- All personnel who may be expected to use this equipment must be thoroughly trained in its safe and proper use.
- Before flowing water from this device, check that all personnel (fire service and civilian) are out of the stream path. Also, check to make sure stream direction will not cause avoidable property damage.
- Become thoroughly familiar with the hydraulic characteristics of this equipment, and the pumping system used to supply it. To produce effective streams, operating personnel must be properly trained.
- Whenever possible, this equipment should be operated from a remote location. Do not needlessly expose personnel to dangerous fire conditions.
- Open water valves supplying this equipment slowly so that piping fills slowly, thus preventing possible water hammer occurrence.
- After each use, and on a scheduled basis, inspect equipment per instructions in the Maintenance section.
- Any modifications to the electrical enclosures will destroy the NEMA 4 rating and void warranty coverage of the enclosure and all components within.



Important: Before installing and operating provided equipment, read this manual thoroughly. Proper installation is essential to safe operation.

SYSTEM INFORMATION:

Monitor Serial Number: _____

Monitor Accessories (Nozzle Gallon Age And Type, Types Of Transmitters, Water Valve, Etc.):

EXM2 MONITOR FEATURE CALLOUTS

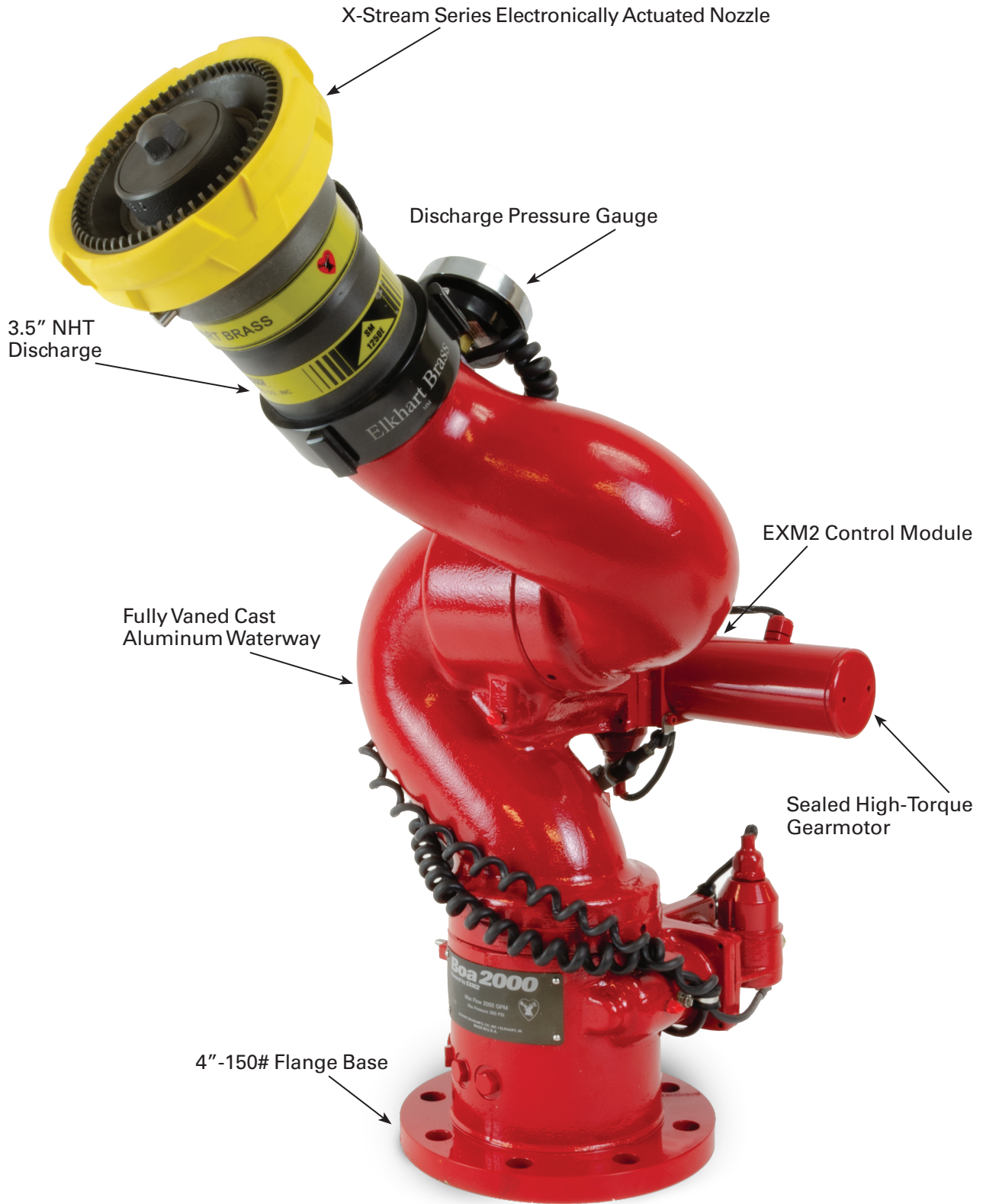

BoaX2 2000 Monitor

SYSTEM COMPONENTS

MONITOR

BoaX2™ 2000 Monitor - 7451X2

The BoaX2 2000 monitor is a cast aluminum monitor with 4" waterway. The waterway contains a central vane to minimize large-scale turbulence and provide superior fire streams. The water supply connection is a 4" -150# ANSI flange. The discharge nozzle connection is a 3 1/2" National Hose male thread.

High power, permanent magnet variable speed DC gear motors that drive the left-right and up-down monitor motions are NEMA 4 rated for use in harsh environments. The monitor utilizes the EXM2 control platform and can be controlled by hardwired input devices via CAN bus or by an optional upgraded Radio Frequency (RF) device. The monitor may be powered with 12 or 24 VDC.



An optional electric valve is available to allow the user to control water flow directly from the EXM input device.

When using the BoaX2 2000 monitor in a horizontal travel range in excess of 90 degrees to the left and 90 degrees to the right of the monitor center position, Keep-Out Zones must be used. The monitor horizontal center position is located at the center of the metal nameplate. Setting a left and right Keep-Out Zone is required to ensure that interference between the discharge elbow and horizontal motor and sensor geometry is prevented. Failure to use Keep-Out Zones as described can result in damage to the monitor. Refer to the Operating Instructions section for more on setting Keep-Out Zones.

A left and right Keep-Out Zone are factory set at Elkhart Brass so that the monitor discharge elbow and stream shaper do not contact the horizontal motor and sensor geometry. If the monitor is recalibrated or if these Keep-Out Zones are removed, new Keep-Out Zones or Travel Limits must be set to prevent potential interferences between these parts.

Factory calibrated center
of horizontal rotation.

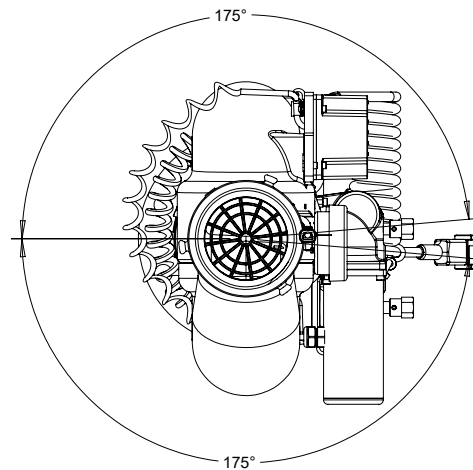



CAUTION: Failure to set Keep-Out Zones or Travel Limits to prevent contact between these parts could result in damage to the monitor. All parts and components damaged this way are not covered under warranty.

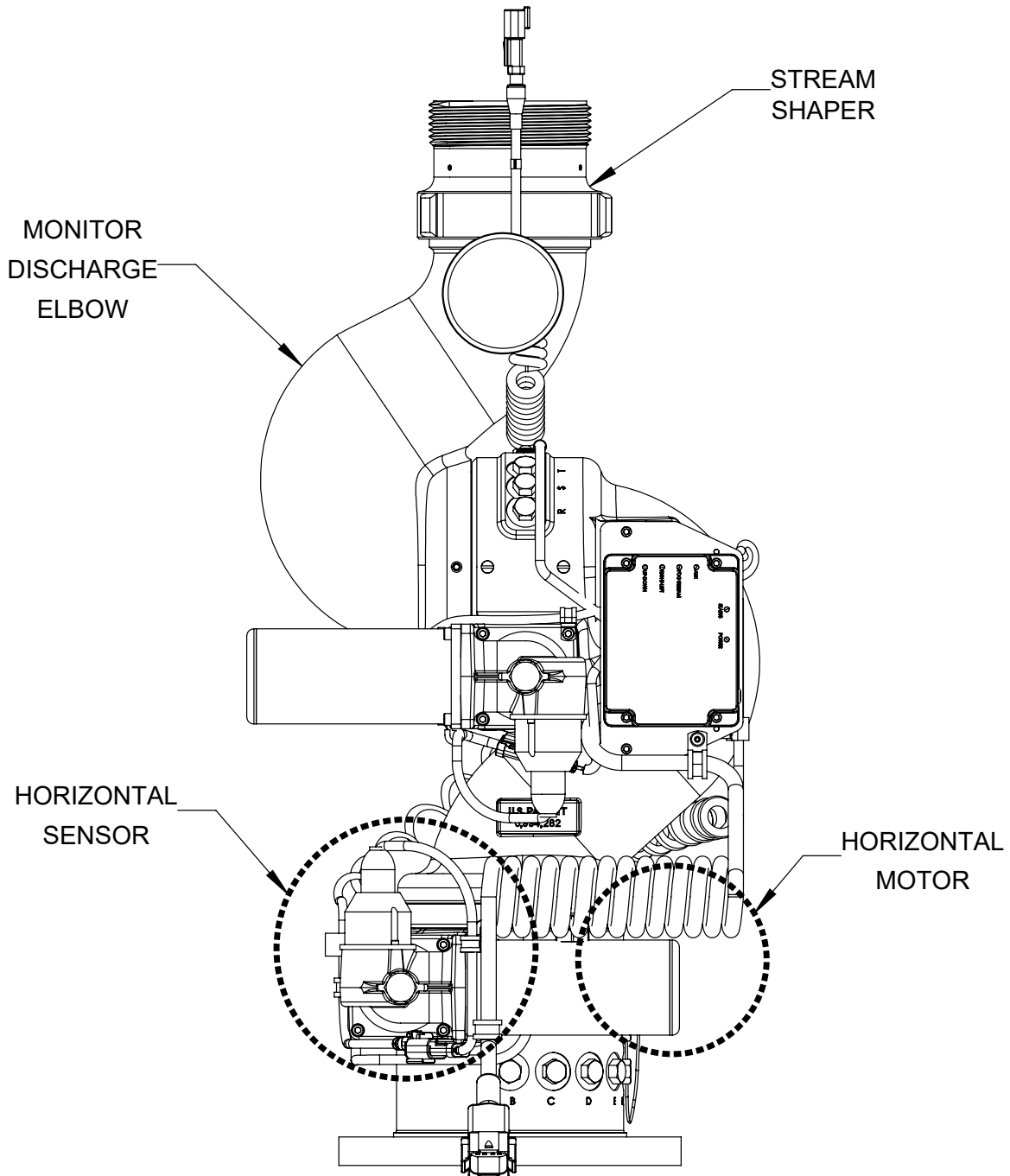

CAUTION: All EXM2 monitor motors are 12VDC. If using a non-EXM2 nozzle, another 12VDC nozzle should be used, or nozzle control may not function properly.

CONTROL

Joystick Controller – 7030X2

The Joystick Controller can be mounted inside the apparatus cab to control all monitor functions, including oscillation, stow and deploy. The monitor direction (both vertical and horizontal movement) is changed by moving the joystick in the desired direction of travel. The up-down and left-right motions can be operated simultaneously with pressure sensitive speed, moving the monitor faster or slower depending on how far the joystick is pushed and pulled. The water valve can be opened with a trigger switch located on the front of the joystick or can be locked into position through the use of the valve buttons on the joystick. Nozzle pattern can be changed using the thumb wheel on the top of the joystick. Oscillation is programmed by using the joystick in conjunction with the oscillate button.



Panel Mount Controller – 7010X2

The Panel Mount Controller is a sealed controller for operation of the monitor, nozzle, and water valve (optional). Separate push button switches are provided for up, down, left, right, fog and straight stream, valve open, valve close, valve preset, stow, deploy, oscillation, and auxiliary functions. The Panel Mount may be powered with 12 or 24 Volts.



Handheld Controller with Docking Station and RF to CAN gateway – 7015X2

The Handheld Controller is a sealed remote control that contains all the controls necessary for operation of the monitor, nozzle, and water valve (optional). The handheld (7015X2 WH) is paired to a RF to CAN gateway (7015X2 GW) and has a docking station (7015X2 DS). The handheld allows the operator to control the monitor from a significantly improved point of view, allowing the operator to confirm that they are hitting the desired target. Separate push buttons are provided for up, down, left, right, fog and straight stream, valve open, valve close, valve preset, stow, deploy, oscillation, and auxiliary functions. The 7015X2, through the use of frequency hopping techniques, allows multiple transmitters to operate on a common site without interference. The remote also has an automatic power down feature that will shut down the power after 5 minutes of no activity. As an additional power saving feature, the radio signal is only transmitted while buttons are pushed. The handheld remote case has a NEMA 4 rating. The Handheld docking station may be powered with 12 or 24 Volts.



Caution: Any modification of the Joystick, Panel Mount, or Handheld Controller enclosures will destroy the NEMA 4 rating to that piece of equipment and will void the warranty coverage.

MONITOR & VALVE ACCESSORIES

Position Feedback Display – 7051X2

All EXM2 monitors come with Absolute Position Feedback sensors. These sensors provide constant feedback to the monitors' processor even when the monitor is moved via manual override. This information is then transmitted to the Position Feedback Display.

Unibody Valve with E14X (E16X for EB6D) Electric Actuator

The Unibody water valve provides a convenient remote on/off and preset valve positioning control of the water supply to the EXM2 monitor. This allows the operator complete control of the unit from the safety of the vehicle cab or handheld radio controller*. The water valve motor speed prevents water hammer, yet closes quickly enough to help preserve the limited on-board water supply. The electric actuated Unibody Valve may be powered with 12 or 24 Volts.

*Valve must be wired for CAN communication with a RF to CAN gateway.



INSTALLATION INSTRUCTIONS

Recommended electrical requirements for BoaX2 2000 monitor:

Distance Ft.(m)	Wire Gauge (AWG)
100(30.5) – 150(45.7)	8
50(15.2) < 100(30.5)	10
25(7.62) < 50(15.2)	14
< 25(7.62)	16

- Power and Ground wire type: Cross Link or equivalent (Must meet or exceed NFPA 1901 Section 13)
- Maximum monitor amperage draw: 20 AMPS (35 AMPS for Foam Tube Expansion)
- CAN wire gauge and length:
 - Main Line: 131 ft. (40 m) – 18-20 AWG (Must meet J1939 specification)
 - Monitor is terminated and must be at the end of the main CAN line
- CAN wire type and shielding: Twisted shielded pair - 105°C 150V (Belden 9841 series or equivalent)
 - Shield Drain: Connect shield/drain to pin C of J1939 connector



WARNING: Turn off system power before connecting or disconnecting an EXM2 component.

Recommended electrical requirements for the EXM2 series input devices:

- Power and Ground wire gauge and length: 18-20 AWG 105°C 150V up to 150 ft. (45.7 m)
- Maximum input controller amperage draw: 500mA
- CAN wire gauge and length: 3 ft. (1 m) – 18-20 AWG
- CAN wire type and shielding: Twisted shielded pair - 105°C 150V (Belden 9841 series or equivalent)
 - Shield Drain: Connect shield/drain to pin C of J1939 connector

Termination Points

When using CAN lines for communication there must be 2 termination points within the system. The monitor should be considered one of these terminating points and located at one end of main CAN line. Termination points are explained further in the Configuration section (installation step 2). What is important at this time is that in order to maximize the efficiency of communication in your CAN network, you must terminate the component located at the opposite end of the main CAN line. This should be taken into consideration as you setup your EXM2 system. Each additional EXM2 component that requires connection to the main CAN communication line between the two end components will require the use of CAN Splitter (P/N 24196000). The maximum length of wire from the main CAN line is 3ft. and would be considered a branch (node) off the main CAN line. A CAN termination plug (P/N 24197000) and CAN splitter (P/N 24196000) may be required to terminate the EXM2 component at the opposite end of the CAN line from the monitor.

INSTALLATION STEP 1: Mount and Wire All System Components

Installation instructions have been included for all EXM components.

BoaX2 2000 Monitor –

- Before mounting the BoaX2 2000 monitor, ensure that space allows for monitor to move through the intended range of motion. Disconnect all electrical connections.
 - The horizontal center of the monitor is marked by the center of the nameplate. The monitor is factory calibrated to move equally to the left and right from this center point.
- Mount the monitor onto an appropriate flat face flange with eight (8) 5/8-11 UNC grade 5, carbon steel or stainless steel bolts & nuts. Seal flange joint with an appropriate full face gasket. Install eight (8) 5/8" flat washers onto the monitor flange side of the connection. Torque bolts uniformly (20 ft-lbs at a time in a crisscross pattern) to 60-70 ft-lbs. Apply blue Loctite 242 or equivalent to the threads.
- The monitor will use a CAN line to communicate with other EXM2 components. Connect the monitor pigtail 1 to CAN bus.
- Supply power to the monitor by connecting the two red and two black leads from the 8 pin connector to an appropriate power source. Install one 20 Amp fuse in line to both positive power leads for a 12V system (10 Amp for 24V system) to protect the monitor electrical components. Be sure the wire gauge is large enough to prevent a voltage drop under load. The voltage at the monitor needs to be 11V or larger during operation. Be sure the final wire size is appropriate for the connector. An OEM-supplied waterproof junction box or splice installed close to the EXM2 monitor may be needed to reduce wire size prior to making the final connections. Refer to recommended electrical requirements for EXM2 monitor on page 8.
- Refer to the respective plug figures for information on the plugs' pins.

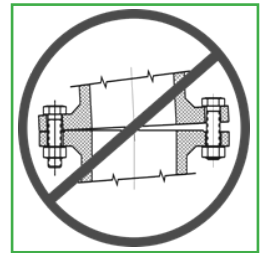

WARNING: When installing the monitor on a raised face companion flange, it is critical that the bolts be tightened uniformly to prevent misalignment of the monitor relative to the flange or valve. If the monitor becomes misaligned, the base flange will fracture and fail when the bolts on the "high" side are tightened.

CAUTION: Do NOT use motors or discharge as leverage to tighten monitor.

1

VIEW FROM WIRE SIDE		DEUTSCH PLUG DT06-3S-P012 NOTE 2	
PIN LETTER	WIRE COLOR	FUNCTION	
A	YELLOW	CAN HI	
B	GREEN	CAN LO	
C	BLACK	SHIELD	

2

POWER / CAN IN			
POSITION	WIRE SIZE	WIRE COLOR	FUNCTION
1	14 AWG	RED	TRUCK POWER
2	14 AWG	RED/WHITE	TRUCK POWER
3	20 AWG	YELLOW	CAN HIGH
4	20 AWG	WHITE	EXT TRAVEL
5	20 AWG	BROWN	STOW
6	20 AWG	GREEN	CAN LOW
7	14 AWG	BLACK	GROUND
8	14 AWG	BLACK/WHITE	GROUND

Stow Output:

The EXM2 monitor provides one electrical output to which an OEM can connect to in order to enable/disable truck operations based on whether an EXM2 monitor is stowed or not stowed. This could be used, for example, for a truck that has an aerial or other movable object that may hit the monitor if moved when the monitor is not stowed. These outputs could also be used to turn OEM-supplied indicator lights on or off depending on the monitor stow state.

- Disconnect monitor power and locate the Power/CAN connector provided with monitor.
- Remove the position 5 plug from the Power/CAN connector.
- Remove the wedge lock from end of the connector.
- Insert the contact end of stow output wire P/N 37241063 into position 5 until it snaps into place.
- Reinstall the wedge lock into the end of the connector.
- Connect the stow output lead to the customer-supplied relay device that the Stow output switches.
 - The stow output provides a ground to this lead when the monitor is not stowed, and provides an open circuit, otherwise.
 - The stow output is limited to 250 mA of current switched to ground (when the monitor is in a non-stowed position).
 - The stow output handles up to +28VDC when open circuit.
 - The stow output maintains the switch state when the monitor is powered off.

Proximity Sensor for Extended Travel:

An OEM supplied proximity sensor is used only for extended travel functionality and is not necessary for standard monitor operation.

The Cobra EXM2 is capable of vertical extended travel beyond the calibration point (straight up). An additional ground input is needed to enable this functionality. This functionality is intended to allow an OEM supplied proximity sensor to be used to enable or disable extended travel when the monitor is used with aerial applications. The proximity sensor should provide an open circuit under normal operation, and a ground when the monitor can move into the extended travel region.

- Disconnect monitor power and locate the Power/CAN connector provided with monitor.
- Remove the position 4 plug from the Power/CAN connector.
- Remove the wedge lock from end of the connector.
- Insert the contact end of the proximity sensor wire P/N 37241000 into position 4 until it snaps into place.
- Reinstall the wedge lock into the end of the connector.
- Reconnect connector and configure the EXM2 system for extended travel functionality before use.

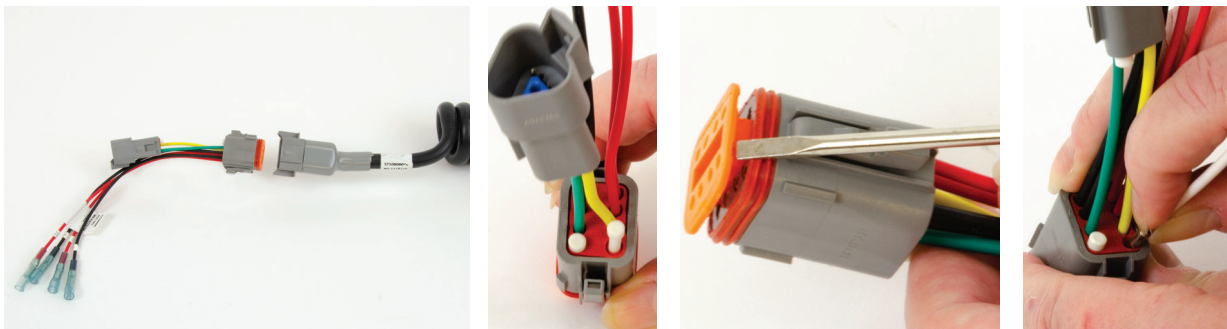

Connecting an OEM supplied proximity sensor to the wire from position 4 will provide conditional extended travel functionality via a ground or open circuit (see Operating Instructions). Connecting the proximity sensor wire from position 4 to a ground will provide an always enabled extended travel.

EXM2 Wiring Connections

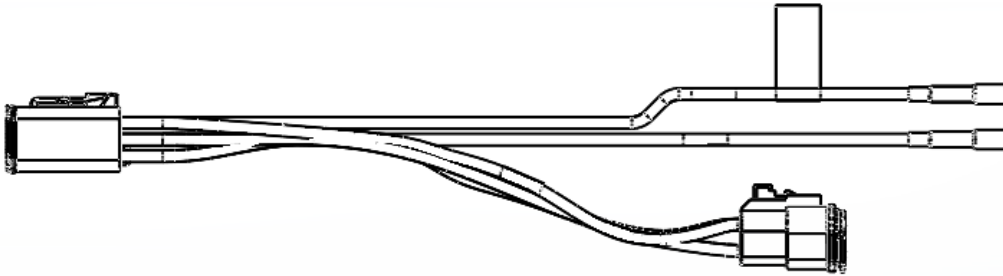

Harness A – P/N 37541000 Controller Pigtail included with EXM2 Panel mount, Position Display, & Joystick

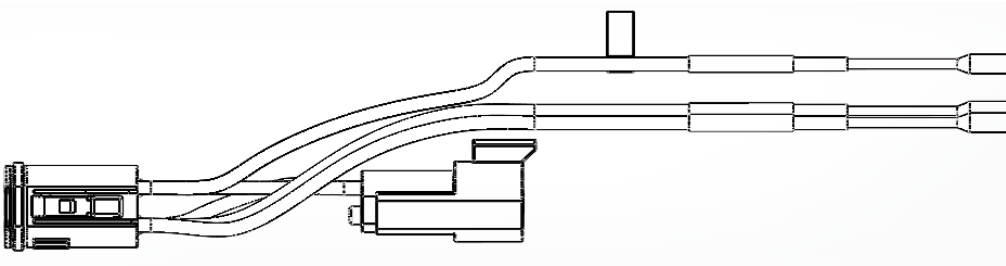

Harness B – P/N 37550000 Monitor Pigtail included with EXM2 monitor

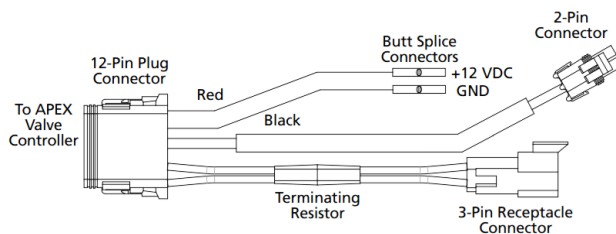

Harness C – P/N 37544000 Valve Pigtail included with E14X/E16X actuator

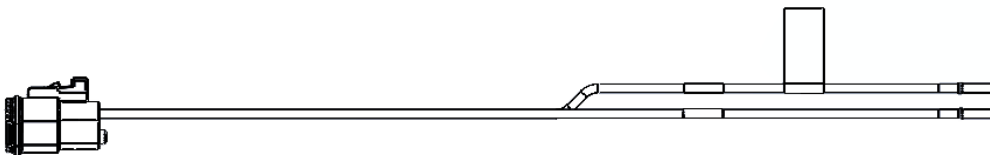

Harness D - P/N375440NT Valve Pigtail non-terminated harness for E14X/E16X valve actuator (optional)

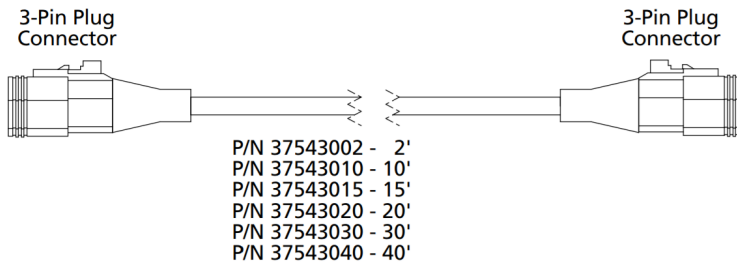

Harness E – EXM2 Extension harness (optional)

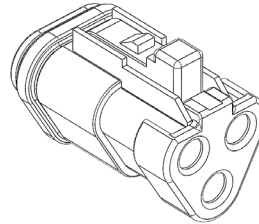
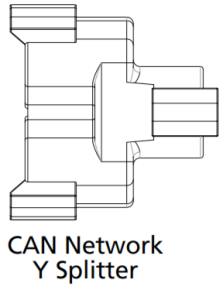

Harness F – P/N 24196000 Splitter (optional)

Harness G – P/N 24197000 CAN Termination Plug (optional)

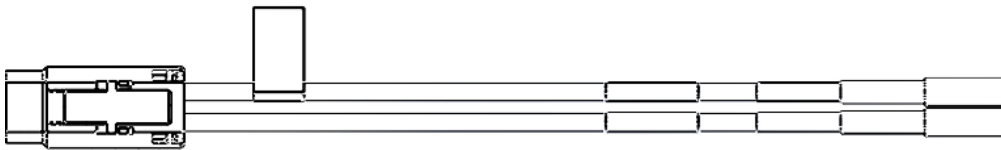

Harness H – P/N 37561000 Docking Station Pigtail included with EXM2 Hand Held pkg

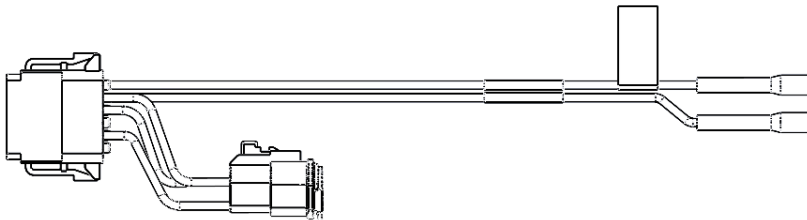

Harness J - P/N37551000 Gateway Pigtail included with EXM2 Hand Held pkg

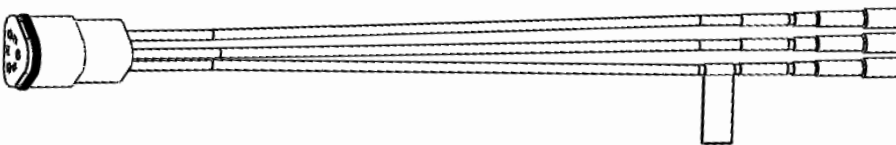

Harness K - P/N 37252000 Monitor CAN J1939 Pigtail

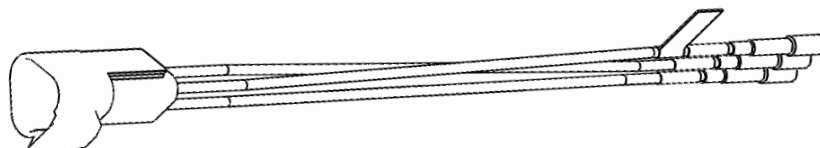

Harness L - P/N 37571000 Input Controller CAN Pigtail

EXM2 Wiring Connections (Shown with all Elkhart Brass Provided harnessing)

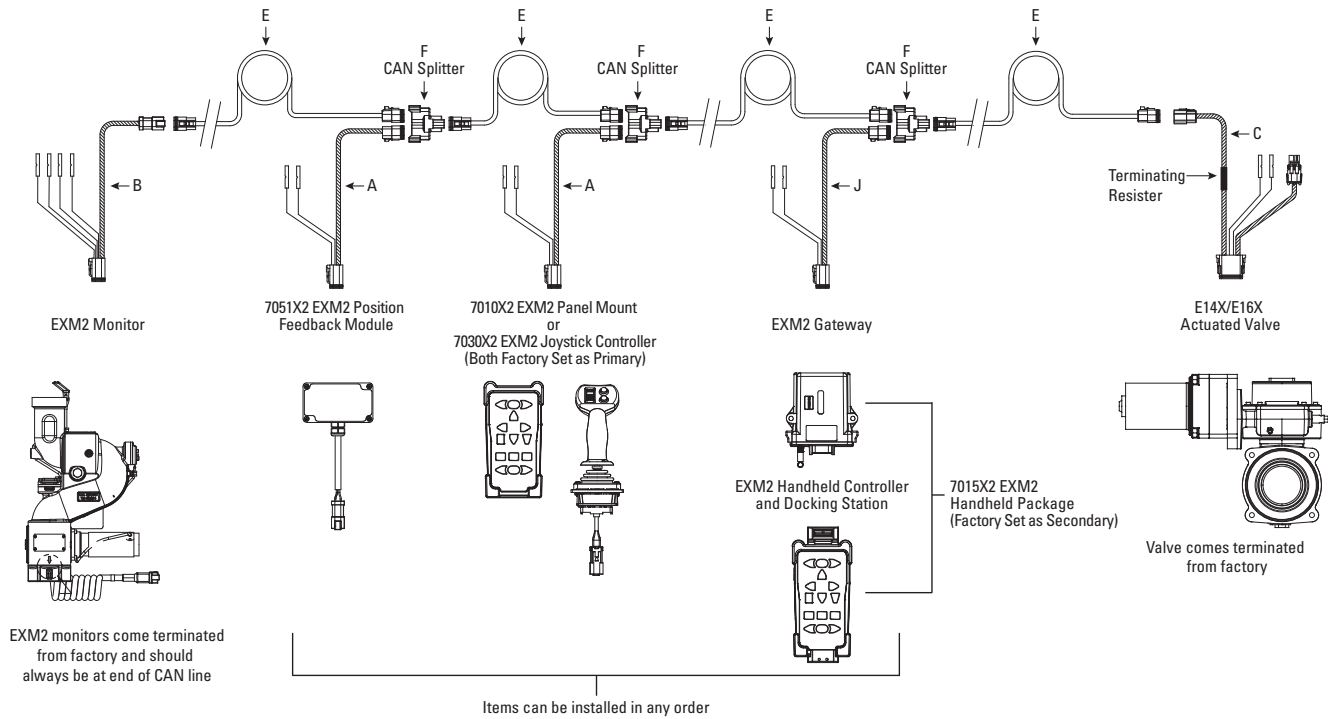

Example of an EXM2 System with a terminated valve at opposite end of main CAN line
(This system does not require configuration)

Panel Mount Controller

- Using the Panel Mount Controller template located at www.elkhartbrass.com, drill 6 #7(0.201" 5.1mm) holes as shown through the panel.
- The device should be mounted in the vehicle such that a minimum separation distance of 7.9" (20 cm) is maintained between the device (and/or its antenna) and any persons during normal operation .
- Mount the controller with six (6) 10-24 screws using blue Loctite 242 or equivalent. The controller has a 0.375 thread depth. Torque screws to 50-60 in-lbs (5.6-6.8 Nm).
- Connect plug 1 to the CAN line.
- Supply power to the controller by connecting plug 2 leads to an appropriate power source. Red (+) and black (-).
- Install a 1 Amp fuse into the positive (red +) power lead for a 12V system (1/2 Amp for 24V system).
- Termination requires CAN splitter (P/N 24196000) and CAN termination plug (P/N 24197000) not included. Non-termination requires CAN splitter (P/N 24196000) not included.
- Refer to the respective plug figures for information on the plugs' pins.



1

VIEW FROM WIRE SIDE		DEUTSCH PLUG DT06-3S-P012 NOTE 2	
PIN LETTER	WIRE COLOR	FUNCTION	
A	YELLOW	CAN HI	
B	GREEN	CAN LO	
C	BLACK	SHIELD	

2

VIEW FROM WIRE SIDE		DEUTSCH PLUG DT06-6S-P012	
PIN NUMBER	WIRE COLOR	FUNCTION	
1	RED	FUSED TRUCK PWR	
2	BLACK	BATT NEGATIVE	
3	PLUG		
4	BLACK	CAN SHIELD	
5	GREEN	CAN LOW	
6	YELLOW	CAN HIGH	

Handheld Controller, Gateway and Docking Station

Docking Station

- Using the Docking Station template located at www.elkhartbrass.com, drill 6 #7(0.201" 5.1mm) drill holes as shown through the panel.
- Mount the Docking Station with six (6) 10-24 screws using blue Loctite 242 or equivalent. The controller has a 0.375 thread depth. Torque screws to 50-60 in-lbs (5.6-6.8 Nm).
- Supply power to the Docking Station by connecting the plug leads shown to an appropriate unswitched power source.
- Install a 1 Amp fuse into the positive (red +) power lead of the Docking Station for a 12V system (1/2 Amp for 24V system).
- Place the Handheld Controller into the station. To remove, push the docking station latch down. (see maintenance instructions section B for LED signals)



Handheld and Docking Station

DEUTSCH CONNECTOR DTM04-2P			
POSITION	WIRE SIZE	WIRE COLOR	FUNCTION
1	20 AWG	RED	POWER
2	20 AWG	BLACK	GROUND

Gateway

- Using the Gateway template located at www.elkhartbrass.com, drill all 0.291"(7mm) holes as shown through the panel.
- Mount the Gateway with 10-24 screws using blue Loctite 242 or equivalent. Torque screws to 50-60 in-lbs (5.6-6.8 Nm).
- In order to comply with FCC and ISED RF Exposure requirements, the device should be mounted in the vehicle such that a minimum separation distance of 20 cm is maintained between the device (and/or its antenna) and any persons during normal operation. This device has been evaluated only with the provided half-wave Lynx 915 MHz antenna and must never be altered by installers/end-users. To allow the antenna to be mounted external to the vehicle and the Gateway to be mounted inside the vehicle out of sunlight, in a dry location with connectors facing down (to help keep the connectors and seals dry) a provided 2m low loss coax is provided.
- Supply power to the controller by connecting red (+) and black (-) leads to an appropriate power source.
- Install a 1 Amp fuse into the positive (red +) power lead of the Gateway for a 12V system (1/2 Amp for 24V system).
- Termination requires CAN splitter (P/N 24196000) and CAN termination plug (P/N 24197000) not included. Non-termination requires CAN splitter (P/N 24196000) not included.



Gateway

DEUTSCH PLUG DTM08-12SA NOTES 1,2			
PIN NUMBER	WIRE COLOR	LABEL	FUNCTION
1	RED	VTRUCK	TRUCK POWER
2	BLACK	GND	GROUND
3	PLUG	N/A	
4	PLUG	N/A	
5	PLUG	N/A	
6	PLUG	N/A	
7	PLUG	N/A	
8	BLACK	SHIELD	CAN SHIELD
9	PLUG	N/A	
10	PLUG	N/A	
11	YELLOW	N/A	J1939 CAN BUS - HIGH SIGNAL
12	GREEN	N/A	J1939 CAN BUS - LOW SIGNAL



DEUTSCH PLUG DT06-3S-P012 NOTE 2			
PIN LETTER	WIRE COLOR	FUNCTION	
A	YELLOW	CAN HI	
B	GREEN	CAN LO	
C	BLACK	SHIELD	

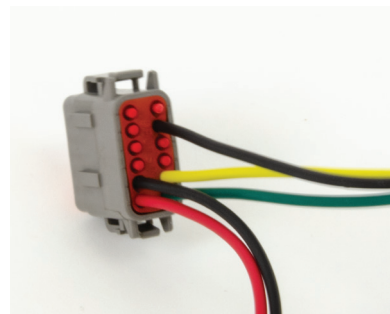
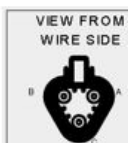

Joystick Controller

- Using the Joystick Controller template located at www.elkhartbrass.com, drill all holes as shown through the panel.
- Mount the Joystick Controller using 4 3/8" fasteners secured with blue Loctite 242 or equivalent.
- Connect plug 2 to the appropriate CAN line.



Joystick Plug Information

1

DEUTSCH CONNECTOR DT04-6P-E005		
POSITION	WIRE COLOR	FUNCTION
1	RED	TRUCK POWER
2	BLACK	GROUND
3	ORANGE	
4	WHITE	CAN SHIELD
5	GREEN	CAN LOW
6	YELLOW	CAN HIGH

2

VIEW FROM WIRE SIDE	DEUTSCH PLUG DT06-3S-P012 NOTE 2		
	PIN LETTER	WIRE COLOR	FUNCTION
	A	YELLOW	CAN HI
	B	GREEN	CAN LO
	C	BLACK	SHIELD

- Supply power to the Joystick by connecting the red (+) and black (-) leads coming from plug 1 to an appropriate power source.
- Install a 1 Amp fuse into the red (+) positive power lead of the joystick for a 12V system (1/2 Amp for 24V system).
- Termination requires CAN splitter (P/N 24196000) and CAN termination plug (P/N 24197000) not included. Non-termination requires CAN splitter (P/N 24196000) not included.
- Refer to the respective plug figures for information on the plugs' pins.

Position Feedback Display

- Using the Position Display template located at www.elkhartbrass.com, drill the two 11/64" holes as shown through the panel intended for mounting the display.
- Mount the Position Feedback Display using two (2) 6-32 x 1/2" fasteners secured with blue Loctite 242 or equivalent. Torque to 50-60 in-lbs (5.6-6.8 Nm).
- Connect plug 2 to the appropriate CAN line.
- Supply power to the Position Feedback Display by connecting plug 1 leads red (+) and black (-) to an appropriate power source.
- Install a 1 Amp fuse into the positive red (+) power lead of the Position Feedback Display for a 12V system (1/2 Amp for 24V system).
- Termination requires CAN splitter (P/N 24196000) and CAN termination plug (P/N 24197000) not included. Non-termination requires CAN splitter (P/N 24196000) not included.
- Refer to the respective figures for information on the plugs' pins.



1

VIEW FROM WIRE SIDE	DEUTSCH DT04-6P-E005			
	PIN NUMBER	WIRE SIZE	COLOR	LABEL
	1	18 AWG	RED	POWER+ (10-30V)
	2	18 AWG	BLACK	GROUND
	3		PLUG	
	4	18 AWG	BLACK	CAN SHIELD
	5	18 AWG	GREEN	CAN LOW
	6	18 AWG	YELLOW	CAN HIGH

2

VIEW FROM WIRE SIDE	DEUTSCH PLUG DT06-3S-P012 NOTE 2		
	PIN LETTER	WIRE COLOR	FUNCTION
	A	YELLOW	CAN HI
	B	GREEN	CAN LO
	C	BLACK	SHIELD



Important: Ensure horizontal & vertical calibration is correct or display may not accurately show position. See Installation Step 3: Calibrate the EXM2 System.

Electric Actuated Unibody Valve – E14X/E16X

- Install the valve into the water supply line.
- Supply power to the valve by connecting the red and black leads coming from the valve -1 plug to an appropriate power source, red (+), black (-). Do not power valve until ready to calibrate it (see page 21).
- Install a 30 Amp fuse to the positive power lead of the valve for a 12V system (20 Amp for 24V system).
- Connect plug 2 to the appropriate CAN line.
- Termination requires no additional items as CAN lead contains termination. Non-termination requires CAN splitter (P/N 24196000, not included) and removal of terminated CAN lead and installation of unterminated lead. Unterminated lead and instructions are included with valve.

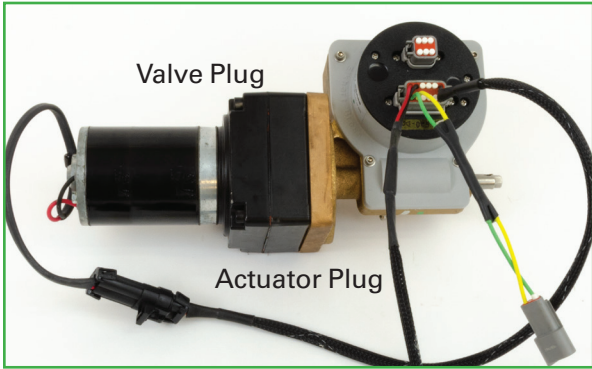

Valve Plug 1

DEUTSCH PLUG DT06-12SA-P012			
PIN NUMBER	WIRE SIZE	WIRE COLOR	FUNCTION
1	14 AWG	RED	FUSED TRUCK POWER
2	14 AWG	BLACK	BATT NEG
3	PLUG		
4	PLUG		
5	PLUG		
6	14 AWG	BLACK	VALVE MOTOR NEG
7	14 AWG	RED	VALVE MOTOR POS
8	PLUG		
9	PLUG		
10	PLUG		
11	18 AWG	YELLOW	CAN HIGH
12	18 AWG	GREEN	CAN LOW

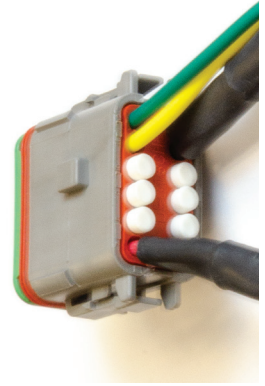

E14X (E16X for EB6D)

2

VIEW FROM WIRE SIDE			DEUTSCH PLUG DT06-3S-P012 NOTE 2		
PIN LETTER	WIRE COLOR	FUNCTION			
A	YELLOW	CAN HI			
B	GREEN	CAN LO			
C	BLACK	SHIELD			

Nozzles

- Ensure there is a gasket inside the nozzle swivel.
- Hand tighten the nozzle onto the monitor discharge.
- Loosen the swivel to reposition the nozzle with the electric actuator on top as shown.
- Tighten the nozzle swivel with a spanner wrench.
- Supply power to the nozzle by connecting the monitor and nozzle harness connectors.



INSTALLATION STEP 2: Configure the EXM2 System

NOTE: EXM2 systems consisting of a monitor and one Panel Mount or Joystick, a handheld with gateway, a position display, and an E14x or E16X actuated valve do not require configuration. EXM2 monitors come factory set for CAN termination and must be at the extreme end of the main CAN line. See options for CAN wiring and termination on page 15.

The following is a list of reasons why a system would require configuration via Wi-Fi:

- Need maximum travel limits to be different than factory setting
- Reversing monitor controls
- Setting priority or controller for override by primary, secondary, or number
- Reversing valve operation when using an EBXJ valve
- Group number used for multiple monitors on system
- Valve ID change for multiple valves
- CAN address for special system of not using Elkhart Brass controls
- Valve closure before stowing monitor need to be turned off

If the system requires configuration, please refer to the EXM2 System Configuration Manual (P/N 98612001) for configuration instructions. You can find the most current manual at www.elkhartbrass.com.

INSTALLATION STEP 3: Calibrate the EXM2 System

NOTE: If calibration was completed during the previous step, skip step 3.

After successfully installing the system, the system must be calibrated. Calibrating the EXM2 monitor's horizontal and vertical rotation is a necessary step for EXM2 systems.

If it was necessary to configure your system using Wi-Fi, calibration can also be done via the Wi-Fi interface. See the EXM2 System Configuration Manual (P/N 98612001) for configuration instructions. You can find the most current manual at www.elkhartbrass.com.

Setup Mode with Controllers

Before the EXM2 system can be calibrated, the system must be put into Setup Mode. To bring the system into Setup Mode simply press and hold the FOG and STREAM buttons simultaneously for 5 seconds (On the joystick use the PRESET and AUX buttons).

- When the system has successfully been brought into Setup Mode, the status LED on the monitor will be lit (magenta) and the status LED on all input controllers will be lit (magenta).
- Once in Setup Mode a user can perform horizontal and vertical calibration of the monitor as well as set travel limits, travel keep out zones, stow position, change motor speeds, etc.
- When in Setup Mode the RIGHT, LEFT, UP, and DOWN buttons function normally, but valve OPEN, CLOSE, and PRESET do not control the valve. Instead, they are used for entering setup commands.
- To exit Setup Mode simply press and release the FOG and STREAM buttons simultaneously one time (On the joystick use the PRESET and AUX buttons). The status LED (magenta) on the monitor and the status LED (magenta) on the input controller will turn off (The joystick status LED will turn solid green).
- Changes made will not take effect until after exiting Setup Mode. Setup Mode will automatically be exited after five minutes of no user inputs.



Caution: There are no vertical or horizontal travel limits when in Setup Mode. **MOVE THE MONITOR WITH CAUTION WHILE IN THIS MODE.** If monitor is obstructed by an object or by itself, the motors may over current and need to be moved manually out of the interfering object's way.

Calibrating Horizontal and Vertical Rotation with Controllers

Calibrating the EXM2 system's horizontal and vertical rotation is a necessary step for EXM2 systems of all types. The calibration points serve as a starting point for all other motion limits and commands entered to the EXM2 system. If not properly calibrated, the system may not operate correctly.

- Enter Setup Mode
- Calibrating Horizontal Rotation - This calibration process will establish the zero (0°) horizontal position and allow rotation half to the left and half to the right of the total rotation range specified during system configuration (i.e. 175 degrees left and 175 degrees right of center for a total of 350 degrees of travel. For Sidewinder EXM2 UHP 90 degrees left and 90 degrees right of center for a total of 180 degrees of travel).
 - Using RIGHT & LEFT controls, position the monitor in the location you want to be the center of the allowed range of horizontal travel (i.e. the 0° horizontal position).
 - Press and hold PRESET and then press and release either the LEFT or RIGHT button. (On the joystick, hold PRESET and move the stick to the right or left and release) The status LED on the monitor should blink then turn solid.
 - Release the PRESET button. The horizontal axis is now calibrated.
- Calibrating Vertical Rotation - (Optional) The Vertical calibration point is factory set at 90° (straight up). This is the position needed when wiring for extended travel (see Operating Instructions E), or when using a Position Feedback Display. This calibration will establish the highest vertical travel point of the monitor and allow rotation in the downward direction the total range specified during system calibration. This differs from the horizontal rotation calibration where the zero point is in the middle of the rotation range. (i.e highest vertical travel point to lowest is 135 degrees not in extended travel except the Magnum EXM2 has 150 degrees).
 - Using the UP & DOWN controls, position the monitor such that it is aimed directly vertical or at the uppermost limit of travel specified during system configuration.
 - Press and hold PRESET and then press and release the UP button. (On the joystick, hold PRESET and pull the stick back and release). The status LED on the monitor should blink then turn solid.
 - Release the PRESET button. The vertical axis is now calibrated.
- Exit Setup Mode and check the monitor's rotation limits. The monitor should not hit itself or other objects. Recalibrate the EXM2 system if needed.



Caution: If the vertical zero point is set too far forward, the monitor may be allowed to crash into itself at the lower points of vertical travel. **BE CAREFUL NOT TO MOVE THE MONITOR INTO OBSTRUCTIONS OR ITSELF** as this will cause the monitor motors to over current. The monitor may need to be manually reversed if this occurs.

Calibrate Valve

NOTE: LEDs flashing above the closed & open buttons on an input controller indicate that the valve has not been calibrated.

If an Elkhart Brass Unibody valve is being used in your system, calibrate it at this time by first placing the valve in a half open position using the manual override, and then pressing and holding the CLOSE and PRESET buttons on any controller until the valve calibration begins. Allow the valve to complete all movements (closed, opened, closed) before entering additional commands to the system.

Calibrate Position Display

Move monitor vertically to both upper and lower limits of travel, then left and right limits of travel. This will calibrate the position display. Dimly lit LEDs will show maximum allowed travel, and the brightly lit LED will show monitor position within the allowed travel. Changes to the travel limits will require recalibration before new limits will be displayed.

INSTALLATION STEP 4: Final Check

After mounting, wiring, configuring (if needed), and calibrating the EXM2 system, check the installation of the entire EXM2 system.

- Ensure that all components have been mounted securely and have had the correct fuses installed within their wiring leads.
- Ensure that all components have been configured (if required) and that all components are functioning.
- Ensure that the EXM2 system has been calibrated correctly for its specific installation.
- Ensure that all components are performing normally.
- For a list of operating functions that the EXM2 system should be capable of performing, go to the operating instructions section.

OPERATING INSTRUCTIONS

A. Button / Joystick Operation

- POWER – Turns Hand Held controller on and off.
- STREAM – Moves the nozzle in order to flow a straight stream of water
(Roll thumbwheel forward on the Joystick)
- FOG – Moves the nozzle in order to flow a fine mist of water
(Roll thumbwheel backward on the Joystick)
- UP – Moves the monitor in the upward direction
(Pull the Joystick handle back)
- STOW – Moves the monitor to a user programmed position. (Press and hold until monitor starts to move)
- DEPLOY – Moves the monitor to a user programmed position. (Press and hold until monitor starts to move)
- DOWN – moves the monitor in the downward direction
(Push the Joystick forward)
- RIGHT – moves the monitor to the right
(Pull the Joystick to the right)
- LEFT – moves the monitor to the left
(Pull the Joystick to the left)
- OSC (OSCILLATE) – Used to set automatic motion of the monitor
(See step I, Oscillation for directions)
- AUX (AUXILIARY) – Used for various operations including light operation, etc.
(See step L, Auxiliary for directions)
- CLOSE – Closes the electric valve within the EXM2 system
(See step K, Valve Operation for directions)
- PRESET – Opens the electric valve to a specified position set by the user
(See step K, Valve Operation for directions)
- OPEN – Opens the electric valve within the EXM2 system
(See step K, Valve Operation for directions)
- TRIGGER (Joystick) – Opens valve when pulled. When released, valve will close.
Double-click trigger and release with initiate valve auto-travel to fully opened. A trigger pull and release afterwards will close valve.

B. LED Meanings

• Monitor LEDs in Normal Operation

- When the monitor is first powered up all LEDs turn on for approximately 1 second, then only the Power LED remains illuminated
- When the monitor control box powers the horizontal motor, the RIGHT-LEFT LED illuminates. (The box may power the motor if it receives a right or left command, a stow/deploy command, etc.)
- When the monitor control box powers the vertical motor, the UP-DOWN LED illuminates. (The box may power the motor if it receives an up or down command, a stow/deploy command, etc.)
- When the monitor control box powers the nozzle motor, the FOG-STREAM LED illuminates. (The box powers the motor if it receives a fog or stream command.)
- The AUX LED illuminates on the monitor control box when the box is providing power to one of its auxiliary outputs. (Switching on a light for example.)
- If Wi-Fi is on, then:
 - The POWER LED blinks blue.
 - The UP-DOWN, RIGHT-LEFT, FOG-STREAM, and AUX LEDs blink blue in a cycling pattern. Once a device connects to the EXM2 Wi-Fi, then the LEDs will blink green in a cycling pattern.
 - The STATUS LED will illuminate solid blue.

- **Monitor LEDs in Setup Mode Operation**

- When in Setup Mode, the status LED on the monitor control box will illuminate Magenta, and depending on motor speeds, the horizontal, vertical, and nozzle LEDs may or may not be lit.

- **Input Controller LEDs (General)**

- **STOW LED**
 - Lit solid = monitor has been stowed and is now at its stow position.
 - Flash = monitor is moving to its stow position.
- **DEPLOY LED**
 - Lit solid = monitor has been deployed and is now at its deploy position.
 - Flash = monitor is moving to its deploy position
- **CLOSE LED**
 - LEDs flashing above both the open & close buttons indicate that the valve needs to be calibrated.
 - Lit solid = valve is in the fully-closed position (unless the user brings the system into Setup or Programming Modes).
 - Flash = valve is closing (whether in auto-travel mode or while holding the CLOSE button).
- **PRESET LED**
 - Lit solid = valve is in the preset position (unless the user brings the system into Setup or Programming Modes).
 - Flash = valve is moving to its preset position (PRESET button has been pushed and released).
- **OPEN LED**
 - LEDs flashing above both the open & close buttons indicate that the valve needs to be calibrated.
 - Lit solid = valve is in the fully-open position (unless the user brings the system into Setup or Programming Modes).
 - Flash = valve is opening (whether in auto-travel mode or while holding the OPEN button).

- **Panel Mount and Handheld Specific LEDs**

- **OSC LED**
 - Lit solid = 1ST oscillate position accepted by monitor. Waiting for 2nd oscillate position.
 - Flash = monitor is auto-oscillating
- **AUX LED**
 - Lit solid = at least one monitor light/auxiliary output is on.
- **EXT LED** – always off

- **Panel Mount STATUS LED**

- Color meanings:
 - Off = normal operation, monitor Wi-Fi is off, monitor and valve is not moving, and this controllers buttons are not being pushed.
 - Green = normal operation
 - Blue = Monitor Wi-Fi is on, normal operation
 - Yellow = a DTC error has occurred (Refer to the Troubleshooting section of this manual)
 - Magenta = in setup or update mode.

- Blink meanings:
 - Green, Blue, or yellow blinking in a 1 blink continuous pattern indicates at least one of the following:
 - the monitor is moving
 - valve is moving
 - a button is being pushed on this panel mount.
 - Magenta blinking indicates that the handheld and it's associated monitor are in setup or update mode.
 - Red blinking indicates handheld is in pairing mode.
- **Wireless Handheld POWER LED**
 - If not loaded on Docking Station
 - Off = handheld off
 - SOLID GREEN = GOOD Battery level
 - SOLIDYELLOW = LOW Battery level
 - FAST BLINKYELLOW = VERY LOW Battery level
 - FAST BLINK RED = CRITICAL Battery level
 - If loaded on Docking Station
 - Off = handheld off, not charging
 - Solid BLUE = handheld off, but charging
 - SOLID CYAN = handheld on, charging, GOOD Battery level
 - SOLIDWHITE = handheld on, charging, LOW Battery level
 - FAST BLINK WHITE = handheld on, charging, VERY LOW Battery level
 - FAST BLINK MAGENTA = handheld on, charging, CRITICAL Battery level
 - SOLID GREEN = handheld on, not charging, GOOD Battery level
 - SOLIDYELLOW = handheld on, not charging, LOW Battery level
 - FAST BLINKYELLOW = handheld on, not charging, VERY LOW Battery level
 - FAST BLINK RED = handheld on, not charging, CRITICAL Battery level
- **Wireless Handheld Specific LEDs (during pairing)**
 - OSC + EXT LED Blinking = clearing previous pairing
 - STOW + DEPLOY (with power LED off)
 - Lit solid = ready to pair RF
 - Blinking = performing RF pairing operations, please wait
- **Wireless Handheld STATUS LED**
 - Color meanings:
 - Off = normal operation, monitor Wi-Fi is off, monitor and valve is not moving, and this controllers buttons are not being pushed.
 - Green = normal operation
 - Blue = Monitor Wi-Fi is on, normal operation
 - Yellow = a DTC error has occurred (Refer to the Troubleshooting section of this manual)
 - Magenta = in setup or update mode.
 - Red-yellow = RF is paired, but not currently communicating to any other RF device
 - Red = RF is not paired (LED is solid) or Handheld is trying to pair (Led is blinking)

- Blink meanings:
 - Green, Blue, or yellow blinking in a 1 blink continuous pattern indicates at least one of the following:
 - the monitor is moving
 - valve is moving
 - a button is being pushed on this panel mount.
- **Joystick STATUS LED**
 - Color meanings:
 - Off = Joystick is not powered
 - Green = normal operation, monitor Wi-Fi is off.
 - Blue = Monitor Wi-Fi is on, normal operation
 - Yellow = a DTC error has occurred (Refer to the Troubleshooting section of this manual)
 - Magenta = in setup or update mode.
- **Docking Station LEDs**
 - RED LED off, Green LED off = The Docking Station is not powered
 - RED LED Solid, Green LED off = The Docking Station has power supplied to it and is not charging a Handheld Controller (waiting for a handheld to be docked).
 - RED LED off, Green LED blinking = The Docking Station is charging a Handheld Controller.
 - RED LED off, Green LED on solid = The Docking Station is not charging a Handheld Controller because Handheld battery is at full capacity.
 - RED LED blinking, Green LED off = The Docking Station is not charging a Handheld Controller due to a battery charging error. Refer to Troubleshooting section of this manual

C. Setup Mode

Before some system programming can be entered into the EXM2 system, the system must be put into Setup Mode.

Please refer back to Step 3 in the Installation Instructions section for directions of how to enter and exit Setup Mode.

NOTE: Changes made in setup mode will not take effect until after exiting setup mode.



Caution: There are no travel limits when in Setup Mode. **MOVE THE MONITOR WITH CAUTION WHILE IN THIS MODE.** Be careful not to move the monitor into obstructions or itself as this will cause the motors to over current. The monitor may need to be manually reversed if this occurs.

D. Re-calibrating Horizontal and Vertical Rotation

Calibrating the EXM2 system's horizontal and vertical rotation is a necessary step for EXM2 systems of all types. The calibration points serve as a starting point for all other motion limits and commands entered to the EXM2 system. If not properly calibrated, the system may not operate correctly.

The EXM2 system should be calibrated from when installation of the EXM2 system occurred, but if it is desired that the monitor's rotation be re-calibrated it is possible to do so. Please refer back to Step 3 in the Installation Instructions section for directions of how to calibrate, or re-calibrate your EXM2 system.

E. Travel Limits

Travel limits are used when it is desired to restrict the motion of the monitor to a smaller, more specific range than the one set at the factory or during system configuration. Travel limits can be used to aid in avoiding objects that may interfere with the motions of the monitor.

It is important to note that travel range cannot be increased further than that range which was set at the factory or as the system default during system configuration. If a larger travel range is desired, this may be able to be changed by reconfiguring the system with the EXM2 Wi-Fi.

• Horizontal Travel Limits

- **Put the EXM2 system into the Setup Mode** (reference Part B of the Operating Instructions section).
- Move the monitor to the intended point of left-most (or right-most) travel.
- The horizontal travel limit should be set within the total allowed factory set travel or total travel specified during configuration of the system. If a travel limit is set outside the intended operating area, operation of the monitor may be unpredictable.
- To set the left-most travel point, press and release the CLOSE button .
(To set the right-most travel point press and release the OPEN button).
- When the EXM2 system is brought out of Setup Mode, horizontal travel limits will be set.

• Vertical Travel Limits

- **Put the EXM2 system into the Setup Mode** (reference Part B of the Operating Instructions section).
- Move the monitor to the intended point of highest (or lowest) travel.
- The vertical travel limit should be set within the total allowed factory set travel or total travel specified during configuration of the system. If a travel limit is set outside the intended operating area, operation of the monitor may be unpredictable.
- To set the highest travel point, hold the STREAM button, press the UP button, then release both buttons. To set the lowest travel point hold the STREAM button, press the DOWN button, then release both buttons. (On the joystick roll the thumbwheel forward and hold it there, then pull back on the joystick to set the highest travel point or push forward to set the lowest travel point. Release the thumbwheel & joystick).
- When the EXM2 system is brought out of Setup Mode, vertical travel limits will be set

F. Extended Travel

The extended-travel-capable EXM2 monitor's maximum vertical travel is dependent on the state of an additional input to position 4 of the 8-pin monitor power connector. This input allows the attachment of an OEM provided proximity sensor to trigger an open or grounded state of operation. The discharge vertical rotation limits from the horizontal center line (discharge parallel to the ground) for the proximity sensor input state are shown in the table below.

Proximity Switch Input	Vertical Max (Degrees)	Vertical Min(Degrees)
Ground	+120°	-45°
Open Circuit	+90°	-45°

The extended travel function will only work if the monitor is properly vertically calibrated (see Installation Step 3) and if the highest vertical travel limit is properly set (see Operation Instructions D).

- The factory set vertical Calibration Point will become the highest point of operation when the proximity switch is in Open Circuit (extended travel disabled). This is factory set to straight up; +90°. The horizontal calibration is unchanged when using extended travel.
- The highest Vertical Travel Limit should be set to the highest point of operation desired when the proximity switch is Grounded (extended travel enabled). This can be up to 30° beyond the vertical Calibration Point. The lowest Vertical Travel Limit cannot be set within the extended travel region.

If the proximity sensor changes the state to disable the extended travel area (Open Circuit) while the discharge is in the extended travel region, the monitor controller will automatically lower the discharge to the Calibration Point.

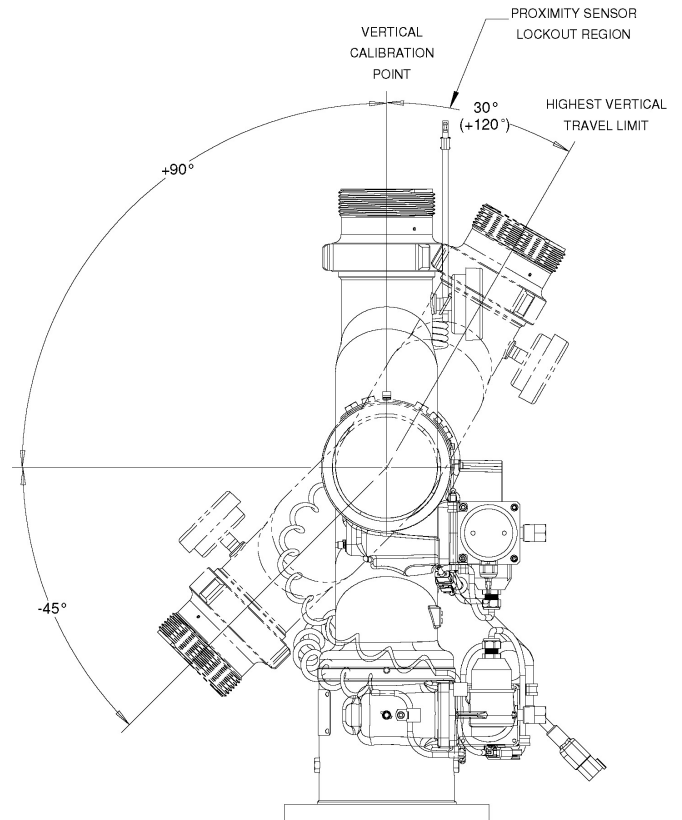

Important: If using a Position Feedback Display with an extended travel monitor, the position display will need to be calibrated after setting new limits.

G. Keep-Out Zones

Keep-Out Zones are used when it is desired to restrict the motion of the monitor to a smaller more specific range than that set at the factory or during system calibration. Keep-Out Zones are different from travel limits in that they do not restrict motion completely in any one direction. Keep-Out Zones can be set to allow the monitor to move above a certain zone or beside the zone to either the left or right.

- **Lower-Right Keep-Out Zone** –The Right Keep-Out Zone will prevent the monitor from moving down and to the right into a specified zone (reference figure 1).
 - **Put the EXM2 system into the Setup Mode** (reference Part B of the Operating Instructions section).
 - Move the monitor to the upper left corner of the keep out zone.
 - The Keep-Out Zone should be set within the previously set monitor calibration points. If a Keep-Out Zone is set outside the intended operating area, operation of the monitor may be unpredictable.
 - Hold the PRESET button, then press the OPEN button, and then release both.
 - When the EXM2 system is taken out of Setup Mode, the monitor will be prevented from moving below and to the right of this point.
- **Lower-Left Keep-Out Zone** –The Left Keep-Out Zone will prevent the monitor from moving down and to the left into a specified zone (reference figure 1).
 - **Put the EXM2 system into the Setup Mode** (reference Part B of the Operating Instructions section)
 - Move the monitor to the top right corner of the keep out zone
 - The Keep-Out Zone should be set within the previously set monitor calibration points. If a Keep-Out Zone is set outside the intended operating area, operation of the monitor may be unpredictable.
 - Hold the PRESET button, the press the CLOSE button, and then release both.
 - When the EXM2 system is taken out of Setup Mode, the monitor will be prevented from moving below and to the left of this point

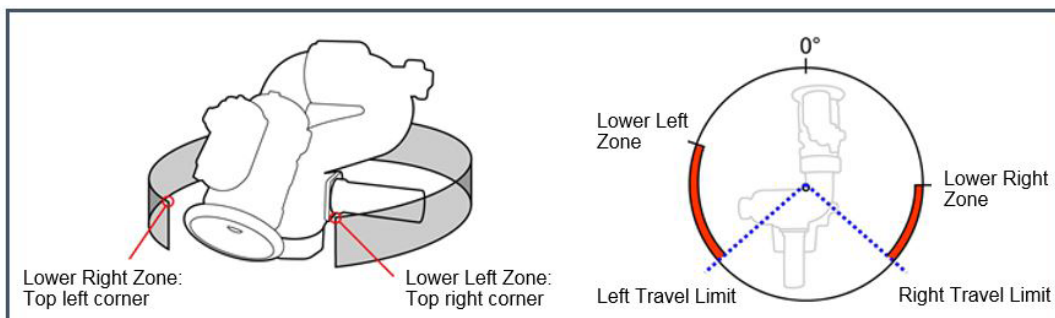

Figure 1: Keep-Out Zones

H. Stow Position

The Stow Position is a preset position that can be used to bring the monitor into a position suitable for when the system is powered off. A stow position must be within the allowed travel area defined by any travel limits or keep-out zones, therefore it is recommended that travel limits and keep-out zones are set before setting a stow position.

- Move the monitor discharge to the desired stow position using the monitor controls. If a travel limit or keep-out zone boundary is met, move the discharge off the boundary a short distance.
- **Put the EXM2 system into the Setup Mode** (reference Part B of the Operating Instructions section).
- Press and release the stow button to program this as the stow position.
- Exit Setup Mode
- Move monitor away from programmed stow position and test stow function. See operation instructions step A, stow, on page 23.



Warning! Water SHOULD NOT be flowing while stowing the monitor.

I. Deploy Position

The Deploy Position is a preset position that can be used to bring the monitor to a user programmed position. A deploy position must be within the allowed travel area defined by any travel limits or keep-out zones, therefore it is recommended that travel limits and keep-out zones are set before setting a deploy position.

- Move the monitor to the desired position. If a travel limit or keep-out zone boundary is met, move the discharge off the boundary a short distance.
- **Put the EXM2 system into the Setup Mode** (reference Part B of the Operating Instructions section).
- Press and release the deploy button to program this as the deploy position.
- Exit Setup Mode
- Move monitor away from programmed deploy position and test deploy function. See operation instructions step A, deploy, on page 23.

J. Motor Speed

The speed of both the horizontal and vertical motors can be changed from something different than that set at the factory or during configuration of the EXM2 system. The monitor's horizontal and vertical motors can be set to either Fast or Slow in one of four combinations.

- **Put the EXM2 system into the Setup Mode** (reference Part B of the Operating Instructions section).
- Press the OSCILLATE button to cycle through the various motor speed combinations.
 - The Yellow LED's (AUX, FOG-STREAM, and RIGHT-LEFT) on the monitor indicates which motor speed combination the monitor will be set at after Setup Mode is exited
 - All Yellow LED's "OFF" places both motors in fast mode
 - One Yellow LED (AUX) only "ON" indicates horizontal motor fast and vertical motor slow mode
 - Two Yellow LED's (AUX and FOG-STREAM) only "ON" indicates horizontal motor slow and vertical motor fast mode
 - Three Yellow LED's (AUX, FOG-STREAM, and RIGHT-LEFT) "ON" places both motors in slow mode
- When the system is brought out of Setup Mode, the motor speeds will be changed to the combination selected.

K. Clear All Function

The Clear All Function allows the user to remove any Travel Limits, Keep-Out Zones, or Stow Positions set while in Setup Mode. When the Clear All Function is used, it will remove all of the previously listed operations. The Clear All Function will not affect calibration points, Motor Speed, or Preset valve positions.

- **Put the EXM2 system into Setup Mode** (reference Part B of the Operating Instructions section).
- Press the OPEN and CLOSE buttons simultaneously.
- All set Travel Limits, Keep-Out Zones, and Stow Positions will be removed from the system.

L. Oscillation

The oscillation function is used to move the monitor back and forth inside a boxed area or straight horizontal or vertical line specified by the user.

- Move the monitor to one corner of the intended boxed area (For a straight horizontal or vertical line, move monitor to the first line endpoint).
- Press the OSCILLATE button. The LED above the OSC will turn on solid (No LED on joystick).
- Move the monitor to the opposite corner of the intended boxed area (For a straight horizontal or vertical line, move monitor to the opposite endpoint of the line.)
- Press the OSCILLATE button a second time. The LED above the OSC will start blinking.
- The monitor should begin moving up and down, and left and right within the boxed area. (If setting a horizontal or vertical line, monitor should begin oscillating horizontally or vertically only.)
- If there is no monitor movement for 30 seconds while setting up the oscillation limits, the monitor will automatically exit oscillate setup.
- Pressing UP, DOWN, LEFT, RIGHT, or OSCILLATE will stop oscillation of a boxed area (Pressing LEFT, RIGHT, or OSCILLATE will stop horizontal oscillation while pressing UP, DOWN, or OSCILLATE will stop vertical oscillation.
 - All other functions can be operated without stopping oscillation.

M. Handheld Controller On/Off

- Pressing the red POWER button turns handheld on or off. After 5 minutes of inactivity, the handheld will automatically shut off to save battery power.

N. Valve Operation

- OPEN – opens the valve. If the button is released, the valve will remain in the current position until another valve operation is performed.
 - In order to initiate auto-travel open, press and hold the OPEN button, then press and release the CLOSE button, then release the OPEN button. The valve will then auto-travel to fully open.
- CLOSE – closes the valve. If the button is released, the valve will remain in the current position until another valve operation is performed.
 - In order to initiate auto-travel close, press and hold the CLOSE button, then press and release the OPEN button, then release the CLOSE button. The valve will then auto-travel to fully closed.
- PRESET – Opens or closes the valve to a preset position.
 - To Change Valve Preset, move the valve to the desired position.
 - Press and hold the PRESET button for 10 seconds
 - The PRESET button will now bring the valve into this position when pressed outside of Setup Mode
- TRIGGER (Joystick Only) – When the Joystick TRIGGER is pulled, the valve will begin opening and stay open as long as the TRIGGER remains pulled. When the TRIGGER is released, the valve will close. Double-click trigger and release will initiate valve auto-travel to fully opened. A trigger pull and release afterwards will close valve.

O. Auxiliary

- Turn on/off optional light 1 – Press AUX button to toggle light on or off.

MAINTENANCE INSTRUCTIONS

Preventive Maintenance

The complete monitor and control system should be inspected during each apparatus check. Careful inspection for damage to the monitor, valve or nozzle is especially important after use of the **EXM2** monitor in emergency operations.

- Operate all possible functions to ensure that each works normally
- Flow water to check the nozzle pattern
 - If the pattern is disrupted, clear the debris
 - If the obstruction still remains, remove the nozzle and check for debris lodged between the nozzle stem and body
- During nozzle flow test, inspect monitor swivel joints and water valve for leaks
- Inspect all exposed wiring for signs of damage

Note: Grease fittings are provided for the up-down and left-right rotation joints, routine greasing should be performed to expel water & other contaminants that can get into the rotation joints. If the monitor is exposed to a high level of radiant heat for a prolonged period, it may be possible for the factory grease to thin and run out of the rotation joints. In such an event, fresh grease should be applied. Use Mobilux EP2 or equivalent. Start at one end of travel range and apply grease through the fitting of each joint until fresh grease comes out the joint. Repeat every 30 degrees throughout the full range of travel on each rotation joint. Wipe off any expelled grease when done.



Caution: DO NOT use high pressure spray to clean the EXM2 System. Using high pressure spray can damage seals and lead to serious damage of electrical components.

TROUBLESHOOTING GUIDE

Understanding System LEDs

• Monitor LEDs

- The STATUS LED blinks yellow if an error occurred that caused the monitor to report a significant Diagnostic Trouble Code and go into safe mode. (The reported error is described through the EXM2 web interface accessed over Wi-Fi.) The blink pattern indicates the condition. The blinks will continue until the monitor control box is reset (power-cycled). The blink pattern is as follows:

Status Blink Pattern	Reason for Safe Mode	Solution
2 blinks continuous	Not Calibrated	Complete Installation Step 3
3 blinks continuous	Sensor Failure	Check wires of the sensor for any damage. Ensure the wires are completely plugged into the control module (Wiring diagram is located at www.elkhartbrass.com). Order a replacement at Elkhart Brass
4 blinks continuous.	Sensor indicates that monitor is moving in the opposite direction of the expected.	Check wiring diagram at www.elkhartbrass.com for motors location.
5 blinks continuous	Sensor did not detect movement on motor when power was applied to either vertical or horizontal motors.	Ensure monitor has power. Check wiring for damage. Order new motors.

- Other LEDs may blink a pattern if an error occurred. The pattern is described in the following table. The monitor is not in safe mode for these errors. The blinks remain until the monitor is reset (power-cycled). (The reported error is also described in the EXM2 web pages accessed over Wi-Fi.)

Blink Pattern	Reason for Notification
Cycle FOG-STREAM and LEFT-RIGHT LEDs (inside 2 of the four LED's grouped on the monitor control box)	Temperature inside the module over 185 degrees F (85 degrees C)
Cycle UP-DOWN and AUX LED's (outside 2 of the four LED's grouped on the monitor control box)	During movement of the monitor, the monitor's input voltage dropped below 10 VDC.

• Panel Mount STATUS LED

- Color meanings:
 - Yellow = a DTC error has occurred
- When not moving or pushing buttons with Wi-Fi off, the STATUS LED blinks a yellow pattern if an error occurred that caused the monitor to report a significant Diagnostic Trouble Code and go into safe mode. (The reported error is described through the EXM2 web interface accessed over Wi-Fi.) The blink pattern indicates the condition. The blinks will continue until the panel mount is reset (power-cycled). The blink pattern is as follows:

Status Blink Pattern	Reason for Safe Mode	Solution
2 blinks continuous	Not Calibrated	Complete Installation Step 3
3 blinks continuous	Sensor Failure	Check wires of the sensor for any damage. Ensure the wires are completely plugged into the control module (Wiring diagram is located at www.elkhartbrass.com). Order a replacement at Elkhart Brass
4 blinks continuous.	Sensor indicates that monitor is moving in the opposite direction of the expected.	Check wiring diagram at www.elkhartbrass.com for motors location.
5 blinks continuous	Sensor did not detect movement on motor when power was applied to either vertical or horizontal motors.	Ensure monitor has power. Check wiring for damage. Order new motors.
6 blinks continuous	During movement of the monitor, the monitor's input voltage dropped below 10 VDC.	Review wiring in installation step one.

• Panel Mount POWER LED

- Green solid = panel mount is powered and communicating via CAN with at least on other EXM2 device.
- Green Blinking = panel mount is not able to communicate on the CAN bus with another EXM2 device.

• Wireless Handheld STATUS LED

- Color meanings:
 - Yellow = a DTC error has occurred
- When not moving or pushing buttons with Wi-Fi off, the STATUS LED blinks a yellow pattern if an error occurred that caused the monitor to report a significant Diagnostic Trouble Code and go into safe mode. (The reported error is described through the EXM2 web interface accessed over Wi-Fi.) The blink pattern indicates the condition. The blinks will continue until the panel mount is reset (power-cycled). The blink pattern is as follows:

Status Blink Pattern	Reason for Safe Mode	Solution
2 blinks continuous	Not Calibrated	Complete Installation Step 3
3 blinks continuous	Sensor Failure	Check wires of the sensor for any damage. Ensure the wires are completely plugged into the control module (Wiring diagram is located at www.elkhartbrass.com). Order a replacement at Elkhart Brass
4 blinks continuous.	Sensor indicates that monitor is moving in the opposite direction of the expected.	Check wiring diagram at www.elkhartbrass.com for motors location.
5 blinks continuous	Sensor did not detect movement on motor when power was applied to either vertical or horizontal motors.	Ensure monitor has power. Check wiring for damage. Order new motors.
6 blinks continuous	During movement of the monitor, the monitor's input voltage dropped below 10 VDC.	Review wiring in installation step one.

• Joystick STATUS LED

- All LEDs Blinking = Joystick is not able to communicate on the CAN bus with another EXM2 device
- Color meanings:
 - Yellow = a DTC error has occurred
- When not moving or pushing buttons with Wi-Fi off, the STATUS LED blinks a yellow pattern if an error occurred that caused the monitor to report a significant Diagnostic Trouble Code and go into safe mode. (The reported error is described through the EXM2 web interface accessed over Wi-Fi.) The blink pattern indicates the condition. The blinks will continue until the panel mount is reset (power-cycled). The blink pattern is as follows:

Status Blink Pattern	Reason for Safe Mode	Solution
2 blinks continuous	Not Calibrated	Complete Installation Step 3
3 blinks continuous	Sensor Failure	Check wires of the sensor for any damage. Ensure the wires are completely plugged into the control module (Wiring diagram is located at www.elkhartbrass.com). Order a replacement at Elkhart Brass
4 blinks continuous.	Sensor indicates that monitor is moving in the opposite direction of the expected.	Check wiring diagram at www.elkhartbrass.com for motors location.
5 blinks continuous	Sensor did not detect movement on motor when power was applied to either vertical or horizontal motors.	Ensure monitor has power. Check wiring for damage. Order new motors.
6 blinks continuous	During movement of the monitor, the monitor's input voltage dropped below 10 VDC.	Review wiring in installation step one.

- Magenta blinking indicates that the controller and monitor are in setup or update mode.

• Docking Station LEDs

- RED LED blinking, Green LED off = The Docking Station is not charging a Handheld Controller due to a battery charging error.

• RF-CAN Gateway LED

- Off = gateway is not powered.
- On Solid = gateway is paired with another RF device.
- Blinking in a 1-blink pattern = gateway is not paired with another RF device.
- Blinking in a 2-blink pattern = gateway is not communicating on the CAN bus.

SYSTEM SPECIFICATIONS

BoaX2 2000 Monitor - 7451X2

Max Flow Rating	2000 GPM (8000 LPM)
Max Operating Pressure	200 PSI (13.8 BAR)
Inlet Size	4"-150# Flange
Outlet Size	3.5" Male NHT
Travel	V: -45° to +120° H: L175° to R175°
Movement	Sealed Electric Motors
Swing Radius	8.9" (226 mm) (360°)
Stow Height	20" (508mm)
Weight	47 Lbs. (21.3 Kg)
Environmental Rating	NEMA 4

BoaX2 2000 Motors

Motor (12 VDC)	Left/Right	Up/Down
Run Current	3 A	3 A
Stall Current	27 A	27 A
Current Trip Point	15 A	15 A

Table 1: Motor Current Specifications

OPTIONAL ACCESSORY SPECIFICATIONS

Panel Mount Controller – 7010X2

Input power	12 or 24VDC Compatible
Electrical Load	0.5 AMPS
Fuse Rating	1 AMPS (12V) & 0.5 AMPS (24V)
Controller Dimensions	7.54in(191.5mm) x 3.85in(97.8mm) X 1.48in(37.6 mm)
Controller Weight	1.15 lbs (0.5kg)
Operating Temperature Range	-40°F to +140°F (-40°C to +60°C)
Environmental Rating	NEMA 4 /IP67

Joystick Controller – 7030X2

Input power	12 or 24VDC Compatible
Electrical Load	0.5 AMPS
Fuse Rating	1 AMPS (12V) & 0.5 AMPS (24V)
Controller Dimensions	8.20in(208.3mm) x 7.8in(196.9mm) X 4.0in(101.6mm)
Controller Weight	2.2 lbs.(1.0kg)
Operating Temperature Range	-40°F to +140°F (-40°C to +60°C)
Environmental Rating	NEMA 4 /IP67

Handheld Controller – 7015X2WH

Input power	Li-Ion 3.7V
Battery Life	3 years
Battery Charge Life	Up to 24 hours operation before recharge required
RF Power Output	Meets FCC part 15 requirements for license free operation (See note on page 38)
Controller Dimensions	7.54in(191.5mm) x 3.85in(97.8mm) X 2.38in(60.5mm)
Controller Weight	1.3 lbs.(0.6kg)
Operating Temperature Range	-40°F to +140°F (-40°C to +60°C)
Environmental Rating	NEMA 4 /IP67
FCC ID	QT8EXM2WH
Canadian ID	4637A-EXM2GW

Docking Station – 7015X2DS

Input power	12 or 24VDC Compatible
Electrical Load	0.5 AMPS
Fuse Rating	1 AMPS (12V) & 0.5 AMPS (24V)
Electromagnetic Compliance	Meets FCC part 15 requirements
Controller Dimensions	8.77in(222.8mm) x 2.0in(50.8mm) x 2.96in(75.2mm)
Controller Weight	0.81 lbs (0.4kg)
Charging Temperature Range	32°F to +140°F (0°C to +60°C)
Environmental Rating	NEMA 4 /IP67

Gateway – 7015X2GW

Input power	12 or 24VDC Compatible
Electrical Load	0.5 AMPS
Fuse Rating	1 AMPS (12V) & 0.5 AMPS (24V)
RF Power Output	Meets FCC part 15 requirements for license free operation (See note on page 39)
Transmitter Dimensions	6.0in(152.4mm)x4.68in(118.87mm)x4.3in(109.22mm)
Transmitter Weight	0.66lbs (0.3kg)
Operating Temperature Range	-40°F to +140°F (-40°C to +60°C)
Environmental Rating	NEMA 4 /IP67
FCC ID	QT8EXM2GW
Canadian ID	4637A-EXM2WH

Valve Controller – E14X/E16X

Input power	12 or 24VDC Compatible
Electrical Load	10 AMPS
Fuse Rating	30 AMPS (12V) & 15 AMPS (24V)
Operating Temperature Range	-40°F to +185°F (-40°C to +85°C)
Environmental Rating	NEMA 4

Position Display – 7051X2

Input power	12 or 24VDC Compatible
Electrical Load	0.1 AMPS
Fuse Rating	1 AMPS (12V) & 0.5 AMPS (24V)
Controller Dimensions	2.56in(65mm) x 1.58in(40.1mm) X 4.53in(115.1mm)
Controller Weight	0.58lbs (0.3kg)
Operating Temperature Range	-40°F to +140°F (-40°C to +60°C)
Environmental Rating	NEMA 4 /IP67

Gateway

Model: 7015X2GW

FCC ID: QT8EXM2GW

FCC Statements:

Note: This equipment has been tested and found to comply with the limits for a Class A digital device, pursuant to part 15 of the FCC Rules. These limits are designed to provide reasonable protection against harmful interference when the equipment is operated in a commercial environment.

This equipment generates, uses and can radiate radio frequency energy and, if not installed and used in accordance with the instruction manual, may cause harmful interference to radio communications. Operation of this equipment in a residential area is likely to cause harmful interference in which case the user will be required to correct the interference at his own expense.

Modifications made to this equipment not expressly approved by Elkhart Brass Mfg. Co., Inc., could void the users authority to operate the equipment.

FCC and ISED Radio Frequency Exposure WARNING: In order to comply with FCC and ISED RF Exposure requirements, the device should be mounted in the vehicle such that a minimum separation distance of 20 cm is maintained between the device (and/or its antenna) and any persons during normal operation. This device has been evaluated only with the provided half-wave Lynx 915 MHz antenna and must never be altered by installers/end-users. To allow the antenna to be mounted external to the vehicle and the Gateway to be mounted inside the vehicle out of sunlight, in a dry location with connectors facing down (to help keep the connectors and seals dry) a provided 2m low loss coax is provided.

HVIN: EXM2GW

IC: 4637A-EXM2GW

Innovation, Science and Economic Development Canada (ISED) Statements:

RSS-Gen and RSS-210 statement:

This device complies with Industry Canada license-exempt RSS standard(s). Operation is subject to the following two conditions: (1) this device may not cause interference, and (2) this device must accept any interference, including interference that may cause undesired operation of the device.

Le present appareil est conforme aux CNR d'Industrie Canada applicables aux appareils radio exempts de licence. L'exploitation

est autorisée aux deux conditions suivantes : (1) l'appareil ne doit pas produire de brouillage, et (2) l'utilisateur de l'appareil doit accepter tout brouillage radioélectrique subi, meme si le brouillage est susceptible d'en compromettre le fonctionnement.

RSS-102 Statement:

This equipment complies with Industry Canada radiation exposure limits set forth for an uncontrolled environment.

Cet equipement est conforme a l'exposition aux rayonnements industry Canada limites établies pour un environnement non contrôlé.

RSS-GEN 6.8 Statement:

This radio transmitter, 4637A-EXM2GW, has been approved by Innovation, Science and Economic Development Canada to operate with the antenna types listed below, with the maximum permissible gain indicated. Antenna types not included in this list that have a gain greater than the maximum gain indicated for any type listed are strictly prohibited for use with this device.

This device has been designed to operate with the antennas listed below, and having a maximum gain of 1.2 dBi. Antennas not included in this list or having a gain greater than 1.2 dBi are strictly prohibited for use with this device. The required antenna impedance is 50 ohms.

Approved antenna list:

Model Number	Type
ANT-916-CW-HWR-SMA	half-wave center-fed dipole antenna, SMA Connector

Ce transmetteur radio, 4637A-EXM2GW, a été approuvé par Industrie Canada pour fonctionner avec les types d'antenne énumérés ci-dessous avec le gain maximal admissible et l'impédance d'antenne requise pour chaque type d'antenne indiqué. Types d'antennes ne figurent pas dans cette liste, ayant un gain supérieur au maximum le gain indiqué pour ce type, sont strictement interdites pour une utilisation avec cet appareil.

Ce dispositif a été conçu en vue de fonctionner avec les antennes énumérées ci-dessous, et ayant un gain maximal de 1,2 dBi. Il est formellement interdit d'utiliser avec ce dispositif des antennes non comprises dans cette liste ou des antennes ayant un gain supérieur à 1,2 dBi. L'impédance électrique requise pour l'antenne est de 50 ohms.

Liste d'antennes approuvées:

Numéro de modèle	Le genre
ANT-916-CW-HWR-SMA	antenne dipôle demi-onde à alimentation centrale, connecteur SMA

Handheld

Model: 7015X2

FCC ID: QT8EXM2WH

FCC Statement:

Note: This equipment has been tested and found to comply with the limits for a Class A digital device, pursuant to part 15 of the FCC Rules.

These limits are designed to provide reasonable protection against harmful interference when the equipment is operated in a commercial environment.

This equipment generates, uses and can radiate radio frequency energy and, if not installed and used in accordance with the instruction manual, may cause harmful interference to radio communications. Operation of this equipment in a residential area is likely to cause harmful interference in which case the user will be required to correct the interference at his own expense.

Modifications made to this equipment not expressly approved by Elkhart Brass Mfg. Co., Inc., could void the users authority to operate the equipment.

FCC Radio Frequency Exposure WARNING: The Elkhart Brass device radiates radio frequency energy at a level below the United States FCC radio frequency exposure limits. Nevertheless, this device should be used in such a manner that the potential for human contact during normal operation is minimized. For handheld operation, this device has been tested and meets FCC RF exposure guidelines. When not being operated, it is suggested that the handheld device be kept a minimum of 20 cm from the body. This device has been evaluated for and shown compliant with the FCC RF Exposure limits. The unit of measurement for RF exposure is Specific Absorption Rate (SAR). The FCC SAR limits for devices is 1.6W/Kg per 1g of tissue.

IC: 4637A-EXM2WH

RSS-Gen and RSS-210 statement:

This device complies with Industry Canada licence-exempt RSS standard(s). Operation is subject to the following two conditions: (1) this device may not cause interference, and (2) this device must accept any interference, including interference that may cause undesired operation of the device.

Le présent appareil est conforme aux CNR d'Industrie Canada applicables aux appareils radio exempts de licence. L'exploitation est autorisée aux deux conditions suivantes : (1) l'appareil ne doit pas produire de brouillage, et (2) l'utilisateur de l'appareil doit accepter tout brouillage radioélectrique subi, même si le brouillage est susceptible d'en compromettre le fonctionnement.

RSS-102 Statement

This equipment complies with Industry Canada radiation exposure limits set forth for an uncontrolled environment.

Cet équipement est conforme à l'exposition aux rayonnements industrie Canada limites établies pour un environnement non contrôlé.



Elkhart Brass Manufacturing Co., Inc.

1302 W. Beardsley Avenue Elkhart, IN 46514

Tel. (574) 295-8330

Toll Free (800) 346-0250

Fax (574) 293-9914

www.elkhartbrass.com

Email: eb.info@safefleet.net

