

# Boa 2000

Powered by EXM

**Model 7451 Monitor**

**Installation, Operating, & Maintenance Instructions**



## TABLE OF CONTENTS

PRODUCT SAFETY INFORMATION.....	3
MONITOR CALLOUT DRAWING.....	4
SYSTEM COMPONENTS.....	5
INSTALLATION INSTRUCTIONS.....	10
Installation Step 1: Mount and Wire all System Components	11
Installation Step 2: Configure the EXM System	18
Installation Step 3: Calibrate Valve & Position Display	18
Installation Step 4: Check Installation	18
OPERATING INSTRUCTIONS.....	19
MAINTENANCE INSTRUCTIONS.....	29
SYSTEM SPECIFICATIONS.....	31
MONITOR AND NOZZLE HYDRAULIC DATA.....	35
COMPONENT MOUNTING TEMPLATES.....	37

To view the most current parts list, drawings, or demonstrations of common EXM commands, please visit [www.elkhartbrass.com](http://www.elkhartbrass.com)

## PRODUCT SAFETY INFORMATION

- All personnel who may be expected to use this equipment must be thoroughly trained in its safe and proper use.
- Before flowing water from this device, check that all personnel (fire service and civilian) are out of the stream path. Also, check to make sure stream direction will not cause avoidable property damage.
- Become thoroughly familiar with the hydraulic characteristics of this equipment, and the pumping system used to supply it. To produce effective fire streams, operating personnel must be properly trained.
- Whenever possible, this equipment should be operated from a remote location. Do not needlessly expose personnel to dangerous fire conditions.
- Open water valves supplying this equipment slowly so that piping fills slowly, thus preventing possible water hammer occurrence.
- After each use, and on a scheduled basis, inspect equipment per instructions in the Maintenance section.
- Any modifications to the electrical enclosures will destroy the NEMA 4 rating and void warranty coverage of the enclosure and all components within.



**Important: Before installing and operating provided equipment, read this manual thoroughly. Proper installation is essential to safe operation.**

### SYSTEM INFORMATION:

MONITOR SERIAL NUMBER: \_\_\_\_\_

MONITOR ACCESSORIES (NOZZLE GALLONAGE AND TYPE, TYPES OF TRANSMITTERS, WATER VALVE, ETC.):

---

---

---

---

---

---

---

---



**Boa 2000** Monitor

## SYSTEM COMPONENTS

### MONITOR

#### **Boa 2000** Monitor – 7451

The **Boa 2000** monitor is a cast aluminum monitor with 4" waterway. The waterway contains a central vane to minimize large-scale turbulence and provide superior fire streams. The water supply connection is a 4"-150# ANSI flange. The discharge nozzle connection is a 3 1/2" National Hose male thread.

High power, permanent magnet variable speed DC gear motors that drive the left-right and up-down monitor motions are NEMA 4 rated for use in harsh environments. The monitor utilizes the EXM control platform and can be controlled by hardwired input devices via CAN bus or by an optional upgraded Radio Frequency (RF) device. The monitor may be powered with 12 or 24 VDC.

An optional electric valve is available to allow the user to control water flow directly from the EXM input device.



When using the Boa 2000 monitor in a horizontal travel range in excess of 90 degrees to the left and 90 degrees to the right of the monitor center position, Keep-Out Zones must be used. The monitor horizontal center position is located at the center of the metal nameplate. Setting a left and right Keep-Out Zone is required to ensure that interference between the discharge elbow and horizontal motor and sensor geometry is prevented. Failure to use Keep-Out Zones as described can result in damage to the monitor. Refer to the Operating Instructions section for more on setting Keep-Out Zones.

A left and right Keep-Out Zone are factory set at Elkhart Brass so that the monitor discharge elbow and stream shaper do not contact the horizontal motor and sensor geometry. If the monitor is recalibrated or if these Keep-Out Zones are removed, new Keep-Out Zones or Travel Limits must be set to prevent potential interferences between these parts.

Factory calibrated center  
of horizontal rotation.

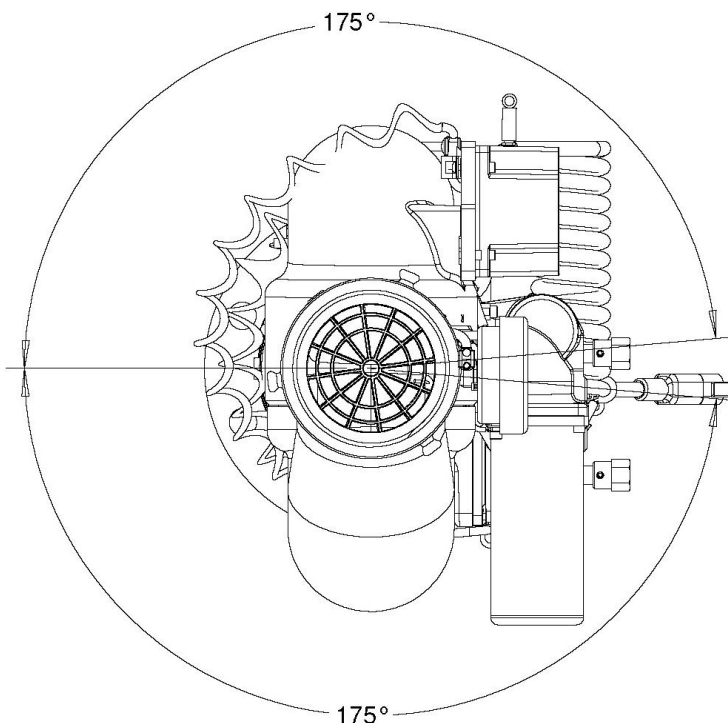



**Caution:** Failure to set Keep-Out Zones or Travel Limits to prevent contact between these parts could result in damage to the monitor. All parts and components damaged this way are not covered under warranty.

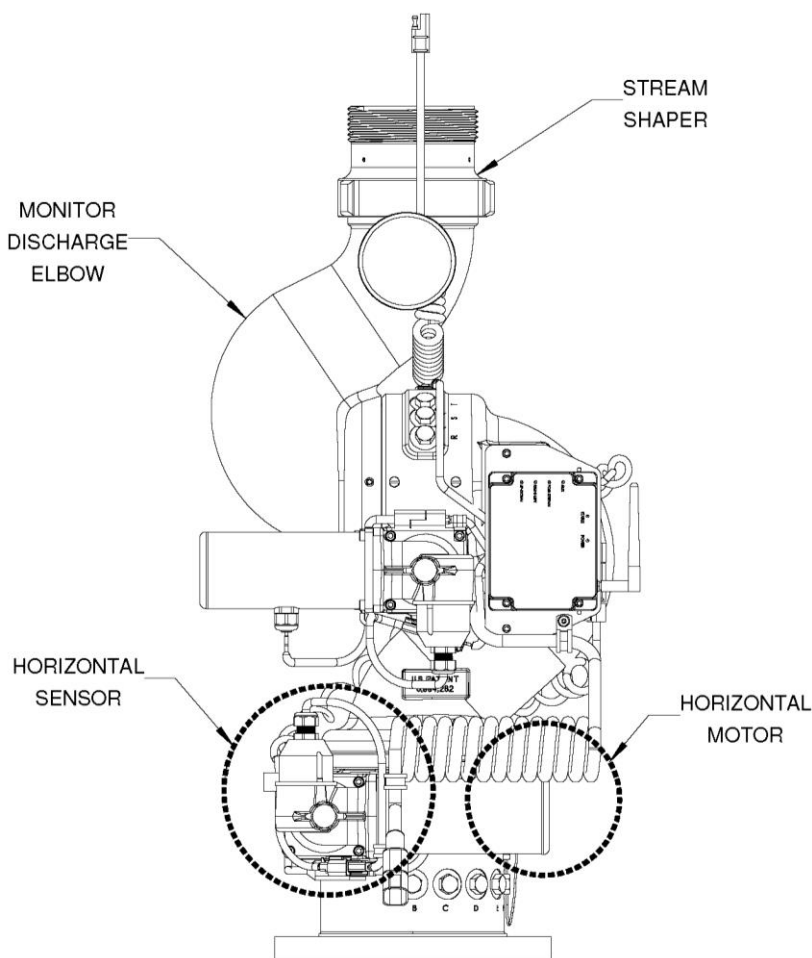

## NOZZLE

### 8294 SCORPION™ EXM Nozzles –

#### SM-1250E & SM-2000E

Each nozzle automatically adjusts to maintain effective stream and maximum reach at variable flows. These nozzles have been calibrated to work at lower pressures, from 75 to 80 PSI, to better suit real world conditions.

SM-1250E; 350 GPM @ 50 PSI - 1250 GPM @ 75 PSI

SM-2000E; 500 GPM @ 50 PSI - 2000 GPM @ 80 PSI



SM-1250E (P/N: 03781211) &  
SM-2000E (P/N: 03990201)



**Caution:** All EXM monitor motors are 12VDC. If using a non-EXM nozzle, another 12VDC nozzle should be used, or nozzle control may not function properly.

## CONTROL

### Joystick Controller - 7030

The Joystick Controller must be used in conjunction with the 7070 OEM Interface Module (Joystick and OEM Interface Module can be ordered together as the 7035 package). The Joystick Controller can be mounted inside the apparatus cab to control all monitor functions, including oscillation. The monitor direction (both vertical and horizontal movement) is changed by moving the joystick in the desired direction of travel. The up-down and left-right motions can be operated simultaneously with pressure sensitive speed, moving the monitor faster or slower depending on how far the joystick is pushed and pulled. The water valve can be opened with a trigger switch located on the front of the joystick or can be locked into position through the use of the valve buttons on the joystick. Nozzle pattern can be changed using the thumb wheel on the top of the joystick. Oscillation is programmed by using the joystick in conjunction with the oscillate button.



### Panel Mount Controller – 7010

The Panel Mount Controller is a sealed controller for operation of the monitor, nozzle, and water valve (optional). Separate push button switches are provided for up, down, left, right, fog and straight stream, valve open, valve close, valve preset, oscillation, and auxiliary functions. The Panel Mount may be powered with 12 or 24 Volts.



### Handheld Controller with Docking Station– 7015

When paired with battery pack, docking station, and RF transceiver module, the Panel Mount Controller becomes a Handheld Controller. The Handheld Controller is a sealed remote control that contains all the controls necessary for operation of the monitor, nozzle, and water valve (optional). The handheld wireless remote allows the operator to control the monitor from a significantly improved point of view, allowing the operator to confirm that they are hitting the desired target. Separate push buttons are provided for up, down, left, right, fog and straight stream, valve open, valve close, valve preset, oscillation, and auxiliary functions. The handheld remote, through the use of frequency hopping techniques, allows multiple transmitters to operate on a common site without interference. The remote also has an automatic power down feature that will shut down the power after 5 minutes of no activity. As an additional power saving feature, the radio signal is only transmitted while buttons are pushed. The handheld remote case has a NEMA 4 rating. The Handheld may be powered with 12 or 24 Volts.



**Caution: Any modification of the Joystick, Panel Mount, or Handheld Controller enclosures will destroy the NEMA 4 rating to that piece of equipment and will void the warranty coverage.**

## OEM Interface Module – 7072 & 7073

The OEM Interface Module is used in conjunction with either the Elkhart Brass or customer supplied joystick, or OEM installed switches. The OEM Interface Module may be configured to handle switching power or ground. The Interface Module provides the option of mounting a joystick or switches in the apparatus cab to control all monitor functions, including oscillation. The OEM Interface Module may be powered with 12 or 24 Volts.

7072 – CAN & RF enabled, internal USB connection

7073 – CAN enabled, sealed external USB connection



7072

7073

For more information about the 7072/7073, please see flyer p/n 98550000 at [www.elkhartbrass.com](http://www.elkhartbrass.com).

## MONITOR ACCESSORY

### Position Feedback Display - 7051

All EXM monitors come with Absolute Position Feedback sensors. These sensors provide constant feedback to the monitors' processor even when the monitor is moved via manual override. This information is then transmitted to the Position Feedback Display.



### EXM CAN Stow Module- 7095

The EXM CAN Stow Module provides electrical outputs to which an OEM can connect to in order to enable/disable truck operations based on whether an EXM monitor is stowed or not stowed. This could be used, for example, for a truck that has an aerial or other movable object that may hit the monitor if moved when the monitor is not stowed. These outputs could also be used to turn OEM-supplied indicator lights on or off depending on the monitor stow state.



### External RF Antenna Module - 7062

The External RF Antenna Module can be utilized with an RF equipped 7070 OEM Interface Module. The 10ft. extension harness allows the antenna to be mounted in a position with a better line of sight to the monitor. Use of the external RF antenna module is required for aerial applications. The external antenna should also be used with the OEM interface module when RF interference is likely.



### RF Transceiver Module - 7061

The RF Transceiver Module can be used with any input controller to enable RF communication within the EXM system.





## CAN Connector Kit - 37221000

This kit provides the wired connectors needed to branch off the main CAN communication line, and allows you to connect another EXM component between the two EXM components at the ends of the main line. **One kit is needed for each additional EXM component that is added to the main CAN line.**

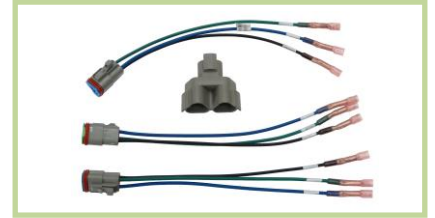

## VALVE

### Unibody Valve with E3F Electric Actuator -

The Unibody water valve provides a convenient remote open, close, and preset valve positioning control of the water supply to the monitor. This allows the operator complete control of the unit from the safety of the vehicle cab or handheld radio controller\*. The water valve motor speed prevents water hammer, yet closes quickly enough to help preserve the limited on-board water supply. The electric actuated Unibody Valve may be powered with 12 or 24 Volts.



\*Valve must be wired for CAN communication with the monitor to allow operation from an "RF ONLY" enabled controller.

## INSTALLATION INSTRUCTIONS

### Installation Overview:

- Step 1 – Mount and Wire All System Components
- Step 2 – Configure the EXM System (If Required)
- Step 3 – Calibrate Valve & Position Display
- Step 4 – Check Installation

### Recommended electrical requirements for **Boa 2000** monitor:

- Power and Ground wire gauge and length:

Distance Ft. (m)	Wire Gauge (AWG)
100 (30.5) – 150 (45.7)	8
< 100 (30.5)	12
- Power and Ground wire type: Cross Link or equivalent (Must meet or exceed NFPA 1901 Section 13)
- Maximum monitor amperage draw: 20 AMPS (35 AMPS for Foam Tube Expansion)
- CAN wire gauge and length:
  - Main Line: 131 ft. (40 m) – 18-20 AWG (Must meet J1939 specification)
  - Branch (node) Line: 3ft. (1 m) – 18-20 AWG (Must meet J1939 specification)
- CAN wire type and shielding: Twisted shielded pair - 105°C 150V (Belden 9841 series or equivalent)
  - Shield Drain: Connect shield/drain to pin C of J1939 connector

### Recommended electrical requirements for the 7000 series input devices:

- Power and Ground wire gauge and length: 18-20 AWG 105°C 150V up to 150 ft. (45.7 m)
- Maximum input controller amperage draw: 500mA
- CAN wire gauge and length: 3 ft. (1 m) – 18-20 AWG
- CAN wire type and shielding: Twisted shielded pair - 105°C 150V (Belden 9841 series or equivalent)
  - Shield Drain: Connect shield/drain to pin C of J1939 connector
- Docking station wire gauge type: 20 AWG cross link or equivalent

### Termination Points:

When using CAN lines for communication there must be 2 termination points within the system. Termination points are explained further in the Configuration section (installation step 2). What is important at this time is that in order to maximize the efficiency of communication in your CAN network, you must terminate the two components at the extreme ends of your main CAN line. This should be taken into consideration as you setup your EXM system. Each additional EXM component that requires connection to the main CAN communication line between the two end components will require the use of CAN Connector Kit (P/N 37221000). The maximum length of wire from the main CAN line is 3ft. and would be considered a branch (node) off the main CAN line.

### CAN Connector Kit:

You may install any of the EXM CAN components that require the use of a CAN Connector Kit (P/N 37221000) by plugging the tri-pin CAN connector from the EXM component directly into the wye connector (Deutsch DT04-3P-P007) of the CAN Connector Kit. You can also use the crimp connectors on the mating connector leads to make your own connection.

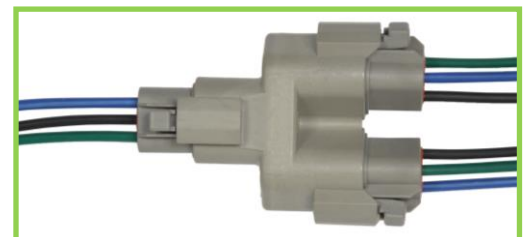

## Installation Step 1: Mount and Wire All System Components

Installation instructions have been included for all EXM components.

### **Boa 2000** Monitor –

- Before mounting the **Boa 2000** monitor, ensure that space allows for monitor to move through the intended range of motion. Disconnect all electrical connections.
  - The horizontal center of the monitor is marked by the center of the nameplate. The monitor is factory calibrated to move equally to the left and right from this center point.
- Mount the monitor onto an appropriate flat face flange with eight (8) 5/8-11 UNC grade 5, carbon steel or stainless steel bolts & nuts. Seal flange joint with an appropriate full face gasket. Install eight (8) 5/8" flat washers onto the monitor flange side of the connection. Torque bolts uniformly (20 ft-lbs at a time in a crisscross pattern) to 60-70 ft-lbs. Apply blue Loctite 242 or equivalent to the threads.
- If the monitor will use a CAN line to communicate with other EXM components, connect plug 1 leads to the appropriate CAN line leads.
  - If the monitor will use RF (radio frequency) to communicate with other EXM components, no preparations are required. The monitor is already RF enabled.
  - If the CAN leads will not be used, replace wires with appropriate plugs.
- Supply power to the monitor by connecting the red and black leads from the 6 pin connector to an appropriate power source. Install a 20 Amp fuse into the positive power lead for a 12V system (10 Amp for 24V system) to protect the monitor electrical components.
- Refer to the respective plug figures for information on the plugs' pins.

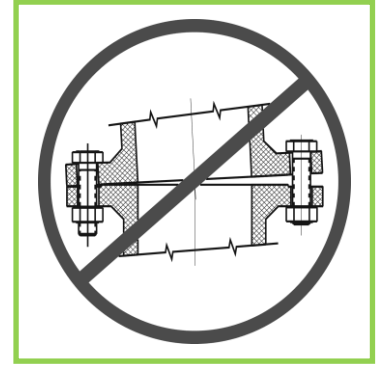

**Caution: Do NOT use motors or discharge as leverage to tighten monitor.**

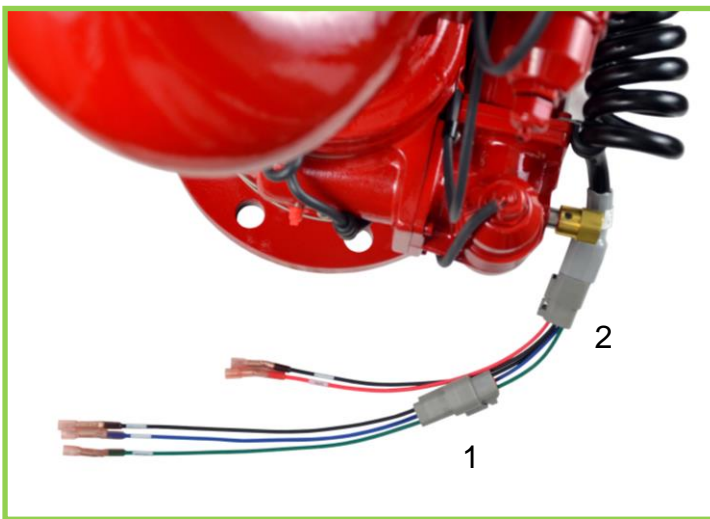

1

CAN - DEUTSCH PLUG #DT06-3S				
VIEW FROM WIRE SIDE	POS 'N	WIRE SIZE	COLOR	FUNCTION
	A	18 AWG	GREEN	CAN LOW
	B	18 AWG	BLUE	CAN HIGH
	C		PLUG	

2

POWER/CAN IN DEUTSCH PLUG #DT06-6S-CE02				
VIEW FROM WIRE SIDE	POS 'N	WIRE SIZE	COLOR	FUNCTION
	1	18 AWG	BLUE	CAN HIGH
	2	14 AWG	BLACK	GND
	3		PLUG	
	4		PLUG	
	5	14 AWG	RED	TRUCK POWER
	6	18 AWG	GREEN	CAN LOW

— LABEL

— LABEL

## Proximity Sensor for Extended Travel –

An OEM supplied proximity sensor is used only for extended travel functionality, and is not necessary for standard monitor operation.

The Boa 2000 is capable of vertical extended travel beyond the factory calibration point (straight up). An additional ground input is needed to enable this functionality. This functionality is intended to allow an OEM supplied proximity sensor to be used to enable or disable extended travel when the monitor is used with aerial applications. The proximity sensor should provide an open circuit under normal operation, and a ground when the monitor can move into the extended travel region.

- Disconnect monitor power and locate the Power/CAN connector provided with monitor.
- Remove the position 3 plug from the Power/CAN connector.
- Remove the orange wedge lock from end of the connector.
- Insert the contact end of the proximity sensor wire into position 3 until it snaps into place.
- Reinstall the orange wedge lock into the end of the connector.
- Reconnect connector and configure the EXM system for extended travel functionality before use.

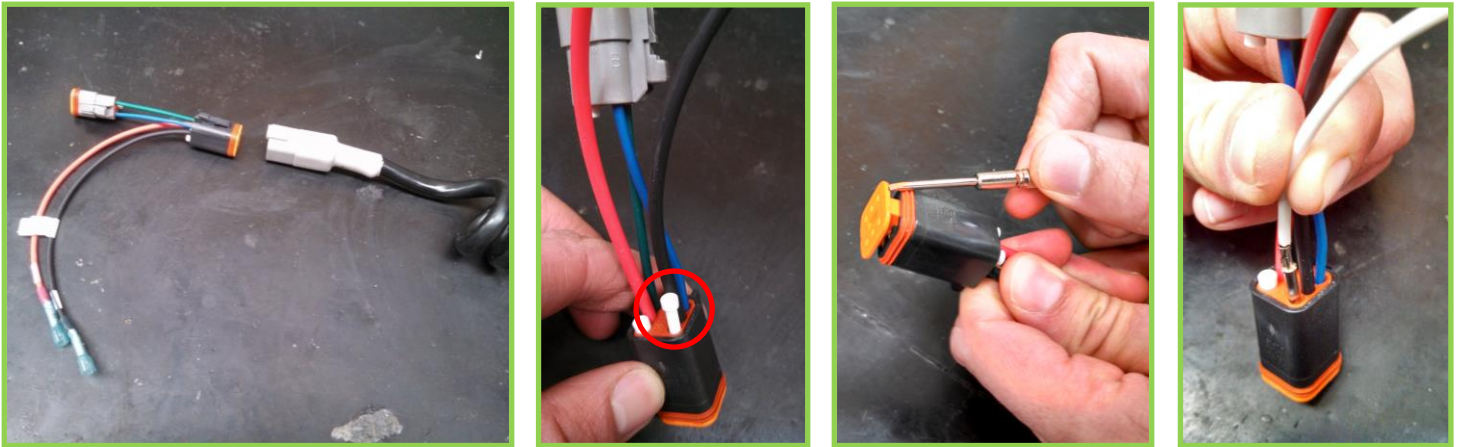

Connecting an OEM supplied proximity sensor to the wire from position 3 will provide conditional extended travel functionality via a ground or open circuit (see Operating Instructions). Connecting the proximity sensor wire from position 3 to a ground will provide an always enabled extended travel.

## Panel Mount Controller -

- Using the Panel Mount Controller template in the Component Mounting Templates section, drill any 4 of the 7/32" holes shown through the panel intended to hold the Panel Mount.
- Mount the controller with four (4) 10-24 x 1/2" screws using blue Loctite 242 or equivalent. Screw length should provide 0.187"-0.25" thread engagement into panel mount. Torque screws to 50-60 in-lbs.
- If the Panel Mount will use the CAN line to communicate with the other EXM components, connect plug 1 leads to the appropriate CAN line.

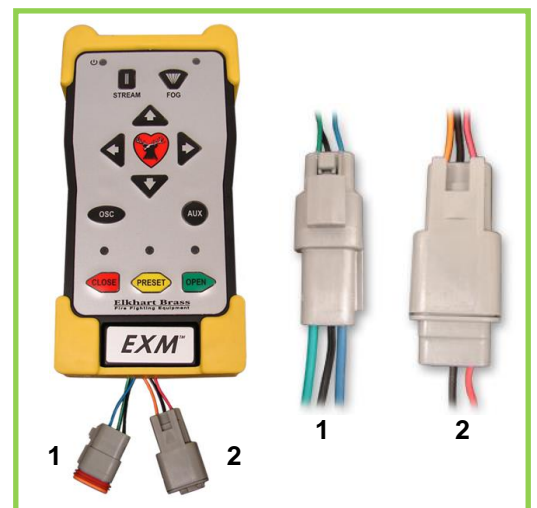

- If the Panel Mount will use RF communication, install the RF Transceiver Module into the controller.
  - Remove the back cover from the Panel Mount Controller using a flathead screwdriver.
  - Connect the RF Transceiver with the wires running the length of the board as shown in the picture to the right.
  - Reattach the back cover of the Panel Mount. Ensure no wires are pinched.
  - If the CAN leads will not be used, replace wires with appropriate plugs.



**RF Transceiver in Panel Mount**

- Supply power to the controller by connecting plug 2 leads to an appropriate power source.
- Install a 1 Amp fuse into the positive power lead for a 12V system (1/2 Amp for 24V system).
- Refer to the respective plug figures for information on the plugs' pins.

**1**

DEUTSCH 3-PIN CAN CONNECTOR			
VIEW FROM WIRE END	TERMINAL	WIRE COLOR	FUNCTION
	A	GREEN	CAN LOW
	B	BLUE	CAN HIGH
	C	BLACK	CAN SHIELD

**2**

DEUTSCH 3-PIN POWER CONNECTOR			
VIEW FROM WIRE END	TERMINAL	WIRE COLOR	FUNCTION
	1	RED	(+) TRUCK POWER
	2	BLACK	(-) GROUND
	3		(+) BATTERY POWER

## Handheld Controller and Docking Station –

- Using the Docking Station template shown in the Component Mounting Templates section, drill all 7/32" holes shown through the panel intended for mounting the Docking Station.
- Mount the Docking Station with the supplied 10-24 x 3/8" screws using blue Loctite 242 or equivalent. Torque screws to 50-60 in-lbs. The screw length allows for a panel thickness range of 0.046"-0.125".
- Supply power to the Docking Station by connecting the plug leads shown to an appropriate unswitched power source.
- Install a 1 Amp fuse into the positive power lead of the Docking Station for a 12V system (1/2 Amp for 24V system).
- Lift the Docking Station top and place the Handheld Controller into the station. Then push the top down until the contacts connect with the handheld. (see maintenance instructions section B for LED signals)
- For instructions on converting a Panel Mount Controller to a Handheld Controller, refer to the steps below.



### Converting the Panel Mount Controller into a Handheld Controller – (Using Handheld Conversion Kit)



- Handheld Conversion Kit will include Battery Pack, Docking Station, and all hardware.
- Install a RF Transceiver Module into the back of the Panel Mount Controller as instructed in the Panel Mount installation section.
- Connect Battery Pack plugs to the Panel Mount Controller as shown.
- The CAN connector will not be used and should be placed inside the Battery Pack as shown.
- Attach Battery Pack to the Panel Mount Controller using the provided 10-24 x 3/4" screws. Torque screws to 50-60 in-lbs.

### Joystick Controller and OEM Interface Module –

- Using the Joystick Controller template shown in the Component Mounting Templates section, drill all holes shown through the panel intended for mounting the Joystick Controller.
- Mount the Joystick Controller using 10-24 x 1/2" fasteners secured with blue Loctite 242 or equivalent.
- Using the OEM Interface template shown in the Component Mounting Templates section, drill all 4 of the 7/32" holes shown.
- Mount the OEM Interface Module with four (4) 10-24 x 1/2" fasteners secured with blue Loctite 242 or equivalent.
- Connect the plug coming from the valve buttons on the Joystick Controller to the valve plug on the OEM Interface Module. (See picture below)
- Connect the plug coming from the Joystick Controller stick to plug 4 on the OEM Interface Module. (See picture below)
- If the Joystick/OEM will use CAN communication, connect the green, black, and blue leads coming from plug 1 to the appropriate CAN line. If the CAN leads will not be used, replace wires with plugs.

**Note:** CAN communication must be used with the 7073 OEM version. CAN or RF communication may be used with the 7072 OEM version.

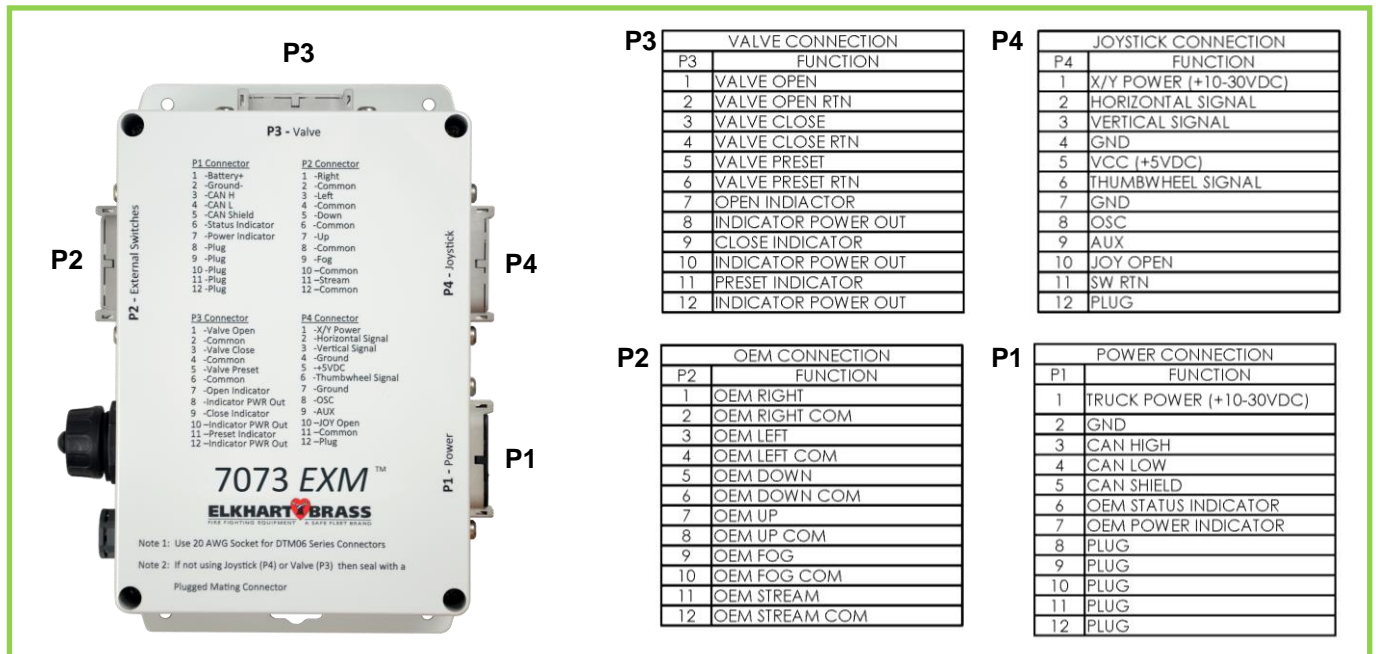

- Supply power to the OEM Interface Module and Joystick by connecting the red and black leads coming from plug 1 to an appropriate power source.
- Install a 1 Amp fuse into the positive power lead of the OEM Interface Module for a 12V system (1/2 Amp for 24V system).
- Refer to the respective plug figures for information on the plugs' pins.
- For information regarding external switches and customer supplied joysticks, refer to the pin information found on the OEM Interface Module cover and the OEM Interface Module Wiring Supplement manual (P/N 98535000).
  - If using a customer-supplied joystick or switches, all controls being used with the OEM Interface Module must be customer-supplied.
  - Customer-supplied controls/switches and the Elkhardt Brass Joystick may not be used simultaneously.
- If there are any unused OEM Interface Module connections plug the connections with appropriate Deutsch connectors and plugs.

### Position Feedback Display –

- Using the Position Display template shown in the Component Mounting Templates section, drill the two 11/64" holes shown through the panel intended for mounting the display.
- Mount the Position Feedback Display using two (2) 6-32 x 1/2" fasteners secured with blue Loctite 242 or equivalent. Torque to 50-60 in-lbs.
- Connect plug 2 leads to the appropriate CAN line.

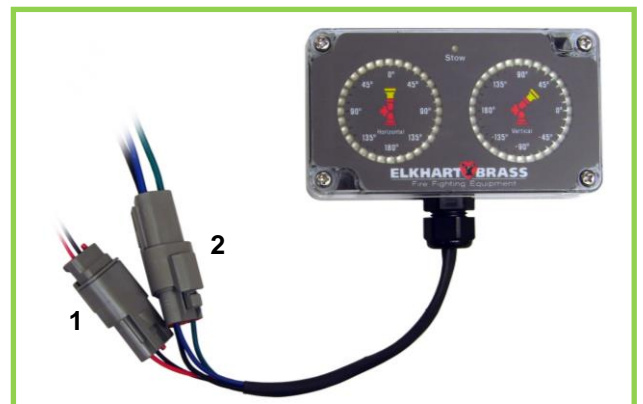

- Supply power to the Position Feedback Display by connecting plug 1 leads to an appropriate power source.
- Install a 1 Amp fuse into the positive power lead of the Position Feedback Display for a 12V system (1/2 Amp for 24V system).
- Refer to the respective figures for information on the plugs' pins.

1

POWER				
VIEW FROM WIRE SIDE	POS 'N	WIRE SIZE	COLOR	LABEL
	1	20 AWG	RED	POWER+ (10-30V)
	2	20 AWG	BLACK	GND
	3		PLUG	

2

CAN				
VIEW FROM WIRE SIDE	POS 'N	WIRE SIZE	COLOR	LABEL
	A	18 AWG	GREEN	A- CAN LOW
	B	18 AWG	BLUE	B- CAN HIGH
	C	18 AWG	BLACK	C- CAN SHIELD

 **Important: Ensure horizontal & vertical calibration is correct or display may not accurately show position. See Installation Step 3: Calibrate the EXM System.**

### EXM CAN Stow Module –

- Using the EXM CAN Stow Module template shown in the Component Mounting Templates section, drill the two (2) 1/4" dia. holes through the surface intended for mounting.
- Mount the Stow Module using two (2) 1/4" dia. fasteners secured with blue Loctite 242 or equivalent.
- Connect Plug 2 leads to the appropriate CAN line.
  - If the Stow Module will be a termination point (at the extreme end of your main CAN line), install the supplied jumper between positions 8 & 9 of the Stow Module Harness.

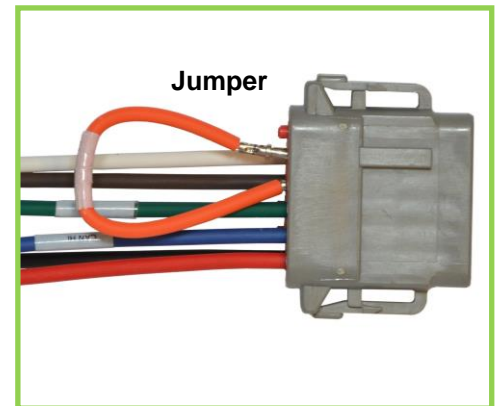
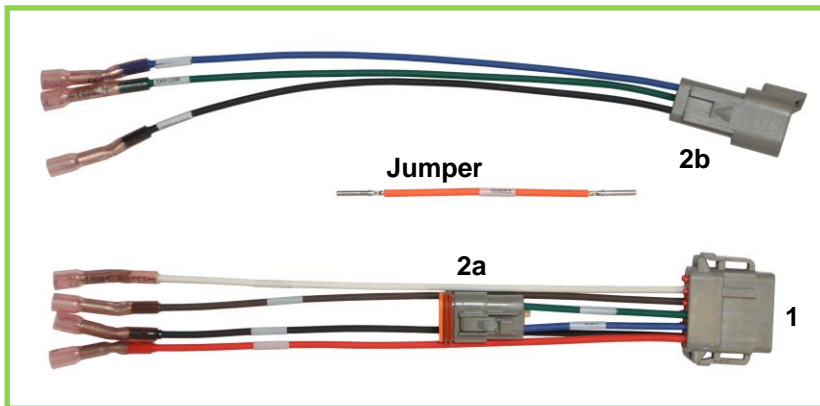

- Connect the Stow indicator leads of the Stow Module Harness to the customer supplied devices that the Stow Module is to actuate.
  - The Stow Module provides a ground to these leads when the EXM monitor is not stowed, and provides an open circuit otherwise.
  - The Stow Lamp lead (position 4) can be used to switch a light or device with a low current draw. There is a 100ohm current-limiting resistor on this signal so that this lead could be directly connected to an LED. (Seal lead if unused)

1

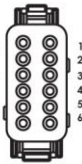
DEUTSCH PLUG DTM06-12S				
VIEW FROM WIRE SIDE	PIN NUMBER	WIRE COLOR	LABEL	FUNCTION
	1	BLACK	GND	TRUCK GND (0 VDC)
	2	EMPTY - PLUG	N/A	RESERVED
	3	EMPTY - PLUG	N/A	RESERVED
	4	BROWN	STOWLAMP	NON-LATCHED STOW INDICATOR OPEN-STOWED GROUND-NOT STOWED MAX SINK-ABLE CURRENT: 140 mA
	5	WHITE	STOWSIGNAL	LATCHED STOW INDICATOR OPEN-STOWED GROUND-NOT STOWED MAX SINK-ABLE CURRENT: 250mA
	6	EMPTY - PLUG	N/A	RESERVED
	7	EMPTY - PLUG	N/A	RESERVED
	8	EMPTY - PLUG	CAN TERM2	(OPTIONAL) 120 CAN TERMINATION JUMPER END 2
	9	EMPTY - PLUG	CAN TERM1	(OPTIONAL) 120 CAN TERMINATION JUMPER END 1
	10	GREEN	CAN LO	J1939 CAN BUS - LOW SIGNAL
	11	BLUE	CAN HI	J1939 CAN BUS - HIGH SIGNAL
	12	RED	POWER	TRUCK POWER (10-30 VDC)

2

DEUTSCH PLUG DT06-3S NOTE 2			
VIEW FROM WIRE SIDE	PIN LETTER	WIRE COLOR	FUNCTION
	A	GREEN	CAN LO
	B	BLUE	CAN HI
	C	EMPTY - PLUG	N/A



- The Stow Signal lead (position 5) can be used to switch a device that may require more current or one that you want to maintain the switch state when the Stow Module is powered off. (Seal lead if unused)
- Supply power to the Stow Module by connecting the RED (power) and BLACK (ground) leads to an appropriate power source.
- Install a 1 Amp fuse into the positive power lead for a 12V system (1/2 Amp for 24V system).

### Electric Actuated Unibody Valve –

- Install the valve into the water supply line.
- Supply power to the valve by connecting the red and black leads coming from the valve plug to an appropriate power source.
- Using the black, green, and blue leads from the plug, connect the valve to the appropriate CAN line.
- Supply power to the valve actuator by connecting the actuator plugs.
- Install a 30 Amp fuse to the positive power lead of the valve for a 12V system (20 Amp for 24V system).

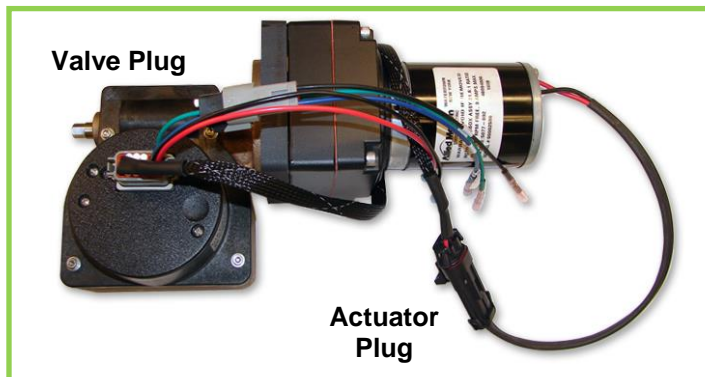

Valve Plug

E3F / E4F (P3) PIN SIGNALS			
VIEW FROM WIRE SIDE	P.3	FUNCTION	WIRE COLOR
	1	POWER 12/24 VDC	RED
	2	GROUND	BLACK
	3	INDICATOR LIGHT CLOSE (12 VDC)	PLUG
	4	INDICATOR LIGHT OPEN (GROUND)	PLUG
	5	AUTO CALIBRATE	PLUG
	6	VALVE CONTROL (-)	BLACK
	7	VALVE CONTROL (+)	RED
	8	CLOSE	PLUG
	9	PRESET	PLUG
	10	OPEN	PLUG
	11	DATALINK CAN HIGH	BLUE
	12	DATALINK CAN LOW	GREEN

### Nozzles –

- Ensure there is a gasket inside the nozzle swivel.
- Hand tighten the nozzle onto the monitor discharge.
- Loosen the swivel to reposition the nozzle as shown (with the electric actuator on top).
- Tighten the nozzle swivel with a spanner wrench.
- Supply power to the nozzle by connecting the monitor and nozzle two-way connectors.



## Installation Step 2: Configure the EXM System

**NOTE:** EXM systems using CAN communication and consisting of a monitor and one controller (panel mount or OEM interface) do not require configuration. EXM monitors and controllers come factory set for CAN termination. A position feedback display can also be used without the need for configuration; as long as it is connected to the main CAN line (see CAN connector kit) between the monitor & controller. The monitor & controller must be at the extreme ends of the main CAN line to provide CAN termination.

If the system requires configuration, please refer to the EXM System Configuration Manual (P/N 98510000) for configuration instructions. You can find the most current manual at [www.elkhartbrass.com](http://www.elkhartbrass.com).

## Installation Step 3: Calibrate Valve & Position Display

### Calibrate Valve

**NOTE:** LEDs flashing above the closed & open buttons on an input controller indicate that the valve has not been calibrated.

If an Elkhart Brass Unibody valve is being used in your system, calibrate it at this time by first placing the valve in a half open position, and then pressing and holding the CLOSE and PRESET buttons on any controller until the valve calibration begins. Allow the valve to complete all movements (closed, opened, closed) before entering additional commands to the system.

### Calibrate Position Display

Move monitor vertically to both upper and lower limits of travel, then left and right limits of travel. This will calibrate the position display. Dimly lit LEDs will show maximum allowed travel, and the brightly lit LED will show monitor position within the allowed travel. Changes to the travel limits will require recalibration before new limits will be displayed.

## Installation Step 4: Check Installation

**After mounting, wiring, configuring, and calibrating, check the installation of the entire EXM system.**

- Ensure that all components have been mounted securely and have had the correct fuses installed within their wiring leads.
- Ensure that all components have been configured (if required) and that all components are functioning.
- Ensure that the EXM system has been calibrated correctly for its specific installation.
- Ensure that all components are performing normally.
  - For a list of operating functions that the EXM system should be capable of performing, go to the operating instructions section.

## OPERATING INSTRUCTIONS

To view a demonstration of some operating commands go to [www.elkhartbrass.com](http://www.elkhartbrass.com) to download the appropriate EXM System Instructional Videos.

### A. Button / Joystick Operation

- **STREAM** – Moves the nozzle in order to flow a straight stream of water  
(Roll thumbwheel forward on the Joystick)
- **FOG** – Moves the nozzle in order to flow a fine mist of water  
(Roll thumbwheel backward on the Joystick)
- **UP** – Moves the monitor in the upward direction  
(Pull the Joystick handle back)
- **DOWN** – moves the monitor in the downward direction  
(Push the Joystick forward)
- **RIGHT** – moves the monitor to the right  
(Pull the Joystick to the right)
- **LEFT** – moves the monitor to the left  
(Pull the Joystick to the left)
- **OSC (OSCILLATE)** – Used to set automatic motion of the monitor  
(See step I, Oscillation for directions)
- **AUX (AUXILIARY)** – Used for various operations including light operation, etc.  
(See step L, Auxiliary for directions)
- **CLOSE** – Closes the electric valve within the EXM system  
(See step K, Valve Operation for directions)
- **PRESET** – Opens the electric valve to a specified position set by the user  
(See step K, Valve Operation for directions)
- **OPEN** – Opens the electric valve within the EXM system  
(See step K, Valve Operation for directions)
- **TRIGGER (Joystick)** – Opens valve when pulled. When released, valve will close.

### B. Setup Mode

In order to setup and utilize some of the EXM system features, the EXM system must first be put into Setup Mode. Many of these features are not needed for basic system operation and should only be used if a specific installation or situation requires them.

To bring the system into Setup Mode, press and hold the FOG and STREAM buttons simultaneously for 5 seconds. (On the joystick use PRESET and AUX buttons)

- When the system has successfully been brought into Setup Mode, the blue status LED on the monitor and the yellow status LED on the input controller (top right corner) will be lit. (There is no status LED on the Joystick. When PRESET and AUX are released, all valve button LEDs will flash once)
- Once in Setup Mode a user can set travel limits, travel keep-out zones, deploy position, stow position, motor speeds, and more
- While in Setup Mode the RIGHT, LEFT, UP, and DOWN buttons function normally, but valve OPEN, CLOSE, and PRESET do not control the valve. Instead, they are used for entering setup commands.
- To exit Setup Mode simply press and release the FOG and STREAM buttons simultaneously one time (On the Joystick use the PRESET and AUX buttons). The blue status LED on the monitor and

the yellow status LED of the input controller will turn off (there is no status LED on the Joystick. All valve button LEDs will flash once instead)

- Changes made will not take effect until after exiting Setup Mode. Setup Mode will automatically be exited after five minutes of no user inputs.

 **Caution:** There are no travel limits when in Setup Mode. MOVE THE MONITOR WITH CAUTION WHILE IN THIS MODE. Be careful not to move the monitor into obstructions or itself as this will cause the motors to over current. The monitor may need to be manually reversed if this occurs.

### C. Extended Travel

The Boa 2000's maximum vertical travel is now dependent on the state of an additional input to position 3 of the 6-pin monitor power connector. This input allows the attachment of an OEM provided proximity sensor to trigger an open or grounded state of operation. The discharge vertical rotation limits from the horizontal center line (discharge parallel to the ground) for the proximity sensor input state are shown in the table below.

Proximity Switch Input	Vertical Max (Degrees)	Vertical Min (Degrees)
Ground	+120°	-45°
Open Circuit	+90°	-45°

The extended travel function will only work if the monitor is properly vertically calibrated and if the highest vertical travel limit is properly set (see Travel Limit and Recalibration Sections for more information).

- The factory set vertical Calibration Point will become the highest point of operation when the proximity switch is in Open Circuit (extended travel disabled). This is factory set to straight up; +90°. The horizontal calibration is unchanged when using extended travel.
- The highest Vertical Travel Limit should be set to the highest point of operation desired when the proximity switch is Grounded (extended travel enabled). This can be up to 30° beyond the vertical Calibration Point. The lowest Vertical Travel Limit cannot be set within the extended travel region.

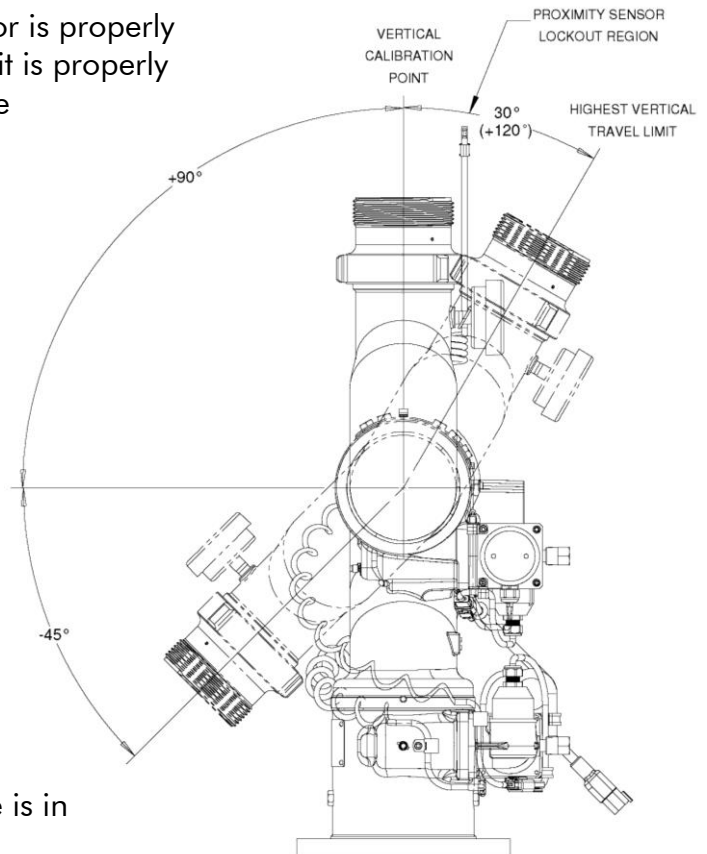

If the proximity sensor changes the state to disable the extended travel area (Open Circuit) while the discharge is in the extended travel region, the monitor controller will automatically lower the discharge to the Calibration Point.

 **Important:** If using a Position Feedback Display with an extended travel monitor, the position display will need to be calibrated after setting new limits.

## D. Travel Limits

Travel limits are used when it is desired to restrict the motion of the monitor to a smaller, more specific range than the one set as default during system configuration. Travel limits can be used to aid in avoiding objects that may interfere with the motions of the monitor.

It is important to note that travel range cannot be increased further than that range which was set as system default during system configuration. If a larger travel range is desired, this must be changed by reconfiguring the system with the EXM Configuration Tool.

**NOTE: If travel limits allow the monitor to make contact with itself or the vehicle, keep-out zones must be set to prevent damage. See Step E.**

- Horizontal Travel Limits
  - **Put the EXM system into the Setup Mode** (reference Part B of the Operating Instructions section)
  - Move the monitor to the intended point of left-most (or right-most) travel
  - The horizontal travel limit should be set within the total allowed factory set travel or total travel specified during configuration of the system. If a travel limit is set outside the intended operating area, operation of the monitor may be unpredictable.
  - To set the left-most travel point, press and release the CLOSE button  
(To set the right-most travel point press and release the OPEN button)
  - When the EXM system is brought out of Setup Mode, horizontal travel limits will be set
  
- Vertical Travel Limits
  - **Put the EXM system into the Setup Mode** (reference Part B of the Operating Instructions section)
  - Move the monitor to the intended point of highest (or lowest) travel
  - The vertical travel limit should be set within the total allowed factory set travel or total travel specified during configuration of the system. If a travel limit is set outside the intended operating area, operation of the monitor may be unpredictable.
  - To set the highest travel point, hold the STREAM button, press the UP button, then release both buttons. To set the lowest travel point hold the STREAM button, press the DOWN button, then release both buttons. (On the joystick roll the thumbwheel forward and hold it there, then pull back on the joystick to set the highest travel point or push forward to set the lowest travel point. Release the thumbwheel & joystick)
  - When the EXM system is brought out of Setup Mode, vertical travel limits will be set

## E. Keep-Out Zones

Keep-Out Zones are used when it is desired to restrict the motion of the monitor to a smaller more specific range than that set during system calibration. Keep-Out Zones are different from travel limits in that they do not restrict motion completely in any one direction. Keep-Out Zones can be set to allow the monitor to move above a certain zone or beside the zone to either the left or right.

- Lower-Right Keep-Out Zone - The Right Keep-Out Zone will prevent the monitor from moving down and to the right into a specified zone (reference figure 1)

- **Put the EXM system into Setup Mode** (reference Part B of the Operating Instructions section)
  - Move the monitor to the upper left corner of the keep out zone
  - The Keep-Out Zone should be set within the previously set monitor calibration points. If a Keep-Out Zone is set outside the intended operating area, operation of the monitor may be unpredictable.
  - Hold the PRESET button, then press the OPEN button, and then release both.
  - When the EXM system is taken out of Setup Mode, the monitor will be prevented from moving below and to the right of this point
- **Lower-Left Keep-Out Zone** - The Left Keep-Out Zone will prevent the monitor from moving down and to the left into a specified zone (reference figure 1)
    - **Put the EXM system into Setup Mode** (reference Part B of the Operating Instructions section)
    - Move the monitor to the top right corner of the keep out zone
    - The Keep-Out Zone should be set within the previously set monitor calibration points. If a Keep-Out Zone is set outside the intended operating area, operation of the monitor may be unpredictable.
    - Hold the PRESET button, then press the CLOSE button, and then release both.
    - When the EXM system is taken out of Setup Mode, the monitor will be prevented from moving below and to the left of this point

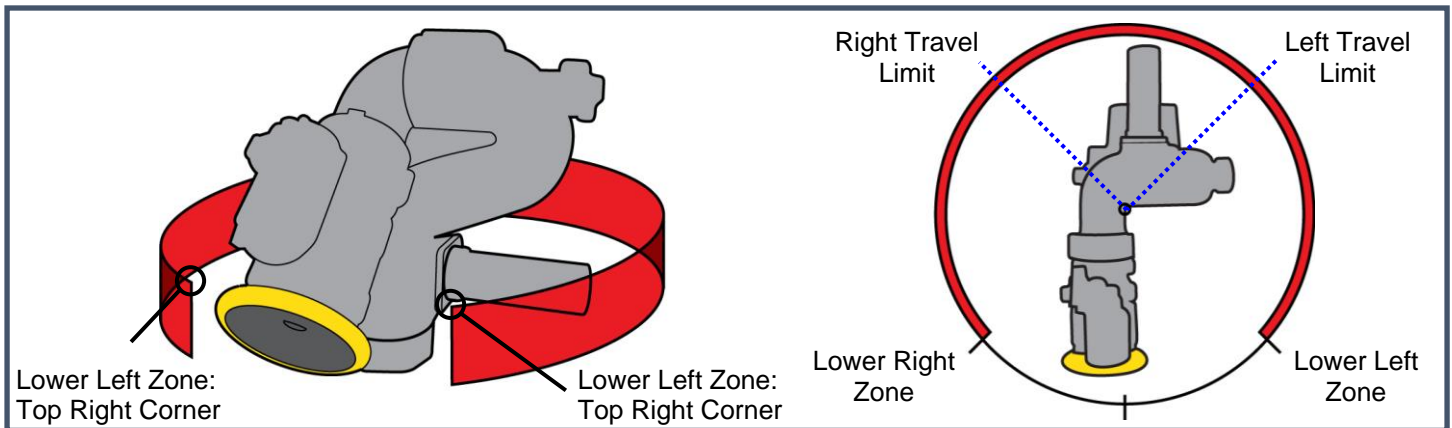

Figure 1: Keep-Out Zones

## F. Stow Position

The Stow Position is a preset position that can be used to bring the monitor into a position suitable for when the system is powered off. A stow position must be within the allowed travel area defined by any travel limits or keep-out zones. Therefore, it is recommended that travel limits and keep-out zones are set before setting a stow position.

- Move the monitor to the desired position while in normal operation (NOT in setup mode). If a travel limit or keep-out zone boundary is met, move the discharge off the boundary a short distance.
- **Put the EXM system into Setup Mode** (reference Part B of the Operating Instructions section)

- Press the FOG and OSCILLATE buttons at the same time (rotate thumbwheel down for FOG on Joystick)
- This position will be the Stow Position when the system is brought out of Setup Mode
- Simply press and hold the FOG and OSCILLATE buttons for three seconds to put the monitor into the Stow Position while outside of Setup Mode (rotate thumbwheel down for FOG on Joystick)



**Warning! Water SHOULD NOT be flowing while stowing the monitor.**

## G. Deploy Position

The Deploy Position is a preset position that can be used to bring the monitor into an initial start position. A deploy position must be within the allowed travel area defined by any travel limits or keep-out zones. Therefore, it is recommended that travel limits and keep-out zones are set before setting a deploy position.

- Move the monitor to the desired position while in normal operation (NOT in setup mode). If a travel limit or keep-out zone boundary is met, move the discharge off the boundary a short distance.
- **Put the EXM system into Setup Mode** (reference Part B of the Operating Instructions section)
- Press the STREAM and OSCILLATE buttons at the same time (rotate thumbwheel up for STREAM on Joystick controller)
- This position will be the Deploy Position when the system is brought out of Setup Mode
- Simply press and hold the STREAM and OSCILLATE buttons for three seconds to put the monitor into the Deploy Position while outside of Setup Mode (rotate thumbwheel up for STREAM on Joystick)



**Warning! Water SHOULD NOT be flowing while deploying the monitor.**

## H. Motor Speed

The speed of both the horizontal and vertical motors can be changed from something different than that set during configuration of the EXM system. The monitor's horizontal and vertical motors can be set to either Fast or Slow in one of four combinations.

- **Put the EXM system into the Setup Mode** (reference Part B of the Operating Instructions section)
- Press the OSCILLATE button to cycle through the various motor speed combinations
  - The horizontal, vertical, and nozzle LED's on the monitor are used to show which motor speed combination the monitor will be set at after Setup Mode is exited
  - All Yellow LED's "OFF" places **both motors in fast mode**
  - One Yellow LED only "ON" indicates **horizontal motor fast** and **vertical motor slow** mode
  - Two Yellow LED's only "ON" indicates **horizontal motor slow** and **vertical motor fast** mode
  - Three Yellow LED's "ON" places **both motors in slow mode**

- When the system is brought out of Setup Mode, the motor speeds will be changed to the combination selected

## I. Clear All Function

The Clear All Function allows the user to remove any Travel Limits, Keep-Out Zones, or Stow Positions set while in Setup Mode. When the Clear All Function is used, it will remove all of the previously listed operations. The Clear All Function will not affect calibration points, Motor Speed, or Preset valve positions.

- **Put the EXM system into Setup Mode** (reference Part B of the Operating Instructions section)
- Press the OPEN and CLOSE buttons simultaneously
- All set Travel Limits, Keep-Out Zones, and Stow Positions will be removed from the system

## J. Oscillation

The oscillation function is used to move the monitor back and forth inside a boxed area or straight horizontal or vertical line specified by the user.

- Move the monitor to one corner of the intended boxed area (For a straight horizontal or vertical line, move monitor to the first line endpoint).
- Press the OSCILLATE button
- Move the monitor to the opposite corner of the intended boxed area (For a straight horizontal or vertical line, move monitor to the opposite endpoint of the line.)
- Press the OSCILALTE button a second time
- The monitor should begin moving up and down, and left and right within the boxed area. (If setting a horizontal or vertical line, monitor should begin oscillating horizontally or vertically only.)
- If there is no monitor movement for 30 seconds while setting up the oscillation limits, the monitor will automatically exit oscillate setup
- Pressing UP, DOWN, LEFT, RIGHT, or OSCILLATE will stop oscillation of a boxed area (Pressing LEFT, RIGHT, or OSCILLATE will stop horizontal oscillation while pressing UP, DOWN, or OSCILLATE will stop vertical oscillation.
  - All other functions can be operated without stopping oscillation.

## K. Handheld Controller Sleep / Hibernation Mode

- Sleep Mode – The Handheld Controller will go into sleep mode after one minute of inactivity. The blue power LED will blink every three seconds while in sleep mode. Any button press will wake the unit up.
- Hibernation Mode – After 5 minutes of inactivity the handheld will go into hibernate mode. All LEDs will be off when the handheld is in hibernate mode. The AUX button is the only button that must be pressed to turn the handheld on at that point.
  - The handheld can be placed in hibernate mode by pressing and holding the AUX button until the power LED turns off.



## L. Valve Operation

- OPEN – opens the valve. If the button is released, the valve will remain in the current position until another valve operation is performed.
  - In order to initiate auto-travel open, press and hold the OPEN button, then press and release the CLOSE button, then release the OPEN button. The valve will then auto-travel to fully open.
- CLOSE – closes the valve. If the button is released, the valve will remain in the current position until another valve operation is performed.
  - In order to initiate auto-travel close, press and hold the CLOSE button, then press and release the OPEN button, then release the CLOSE button. The valve will then auto-travel to fully closed.
- PRESET – Opens or closes the valve to a preset position
  - To Change Valve Preset, move the valve to the desired position.
  - Press and hold the PRESET button for 10 seconds
  - The PRESET button will now bring the valve into this position when pressed outside of Setup Mode
- TRIGGER (Joystick Only) – When the Joystick TRIGGER is pulled, the valve will begin opening and stay open as long as the TRIGGER remains pulled. When the TRIGGER is released, the valve will close.

## M. Auxiliary

- Turn on/off optional light 1 – Hold AUX and press FOG
- Turn on/off optional light 2 – Hold AUX and press STREAM

## N. Write Diagnostic File

- Power up all EXM system components.
- Remove the USB cover from any input controller. (If the system has more than one controller select the one with the easiest access. See illustration below for locations of the USB connection)



**Handheld & Panel Mount -  
Remove the top cover on the  
controller with a phillips  
screwdriver.**



**7072 OEM Interface Module -  
Remove the cover with a  
phillips screwdriver to locate  
the USB port.**



**7073 OEM Interface Module –  
Unscrew the USB port cover.**

- Install a blank USB flash drive into the USB port of the desired input controller, and the controller will automatically enter USB Mode (The following LED routines should occur to indicate USB

mode has been initiated. If USB Mode does not initiate, hold AUX and OSC for 2 seconds and watch for the LED indicators)

- If using a panel mount or hand held, the yellow status LED on the controller will begin to blink at once per second intervals.
- If using Joystick, all valve LEDs will flash once to indicate that you are in USB Mode
- Press and release the OPEN button. The LED above the open button will flash while the information is being downloaded.
- A diagnostic file called EBDIAG.CSV is written to the USB flash drive. When the LED above the open button begins flashing at a 3 second interval, the download is complete.
- Remove the USB from the input controller to leave USB Mode. (On older systems it may be necessary to push the right button on the panel mount or hand held, or move the joystick right, to exit USB mode).
- Contact Elkhart Brass to make arrangements to send the EBDIAG.CSV file for review.

## O. Update Firmware

- Before updating firmware ensure that all components intended for the update are powered up and connected to the chosen input controller through either the CAN line or RF network.
- Remove the USB cover from any input controller.
  - Although any input controller may be used for updating firmware, **it is suggested that a controller connected via the CAN line is used**, if available. Update times can triple when using input controllers communicating over the RF network.
- Install the USB flash drive with the newest firmware version into the USB port of the desired input controller, and the controller will automatically enter USB Mode (The following LED routines should occur to indicate that USB mode has been initiated. If USB Mode does not initiate, hold AUX and OSC for 2 seconds and watch for the LED indicators)
  - If using a panel mount or hand held, the yellow status LED on the controller will begin to blink at once per second intervals.
  - If using Joystick, all valve LEDs will flash once to indicate that you are in USB Mode
- Press and release the PRESET button
- The input controller will read the hex file on the flash drive and install it as long as the copied firmware is newer than the existing firmware.
  - This process will likely take up to ten minutes to complete. If using an RF input controller, update time may be up to three times as long.
  - This action will also update all input controllers on the CAN line (primary and secondary)
  - Once all of the input controllers are updated and there were no errors while upgrading; then the preset LED will blink once every three (3) seconds.
  - If the primary input controller does not recognize it as newer firmware, then no update will take place and the preset LED will flash twice every three (3) seconds.
  - If the update did not perform correctly, the preset LED will blink three times every three (3) seconds. If the update did not perform correctly please call Elkhart Brass at (800) 346-0250.

- Remove the USB flash drive from the input controller to exit USB Mode. (On older systems it may be necessary to push the right button on the panel mount or hand held, or move the joystick right, to exit USB mode).

## P. Recalibrating Horizontal and Vertical Rotation

The Boa 2000 monitor is factory calibrated at Elkhart Brass and recalibration is only necessary in the cases of troubleshooting or sensor replacement. The calibration points serve as a starting point for all other motion limits and commands entered to the EXM system. If not properly calibrated, the system may not operate correctly.

The Boa 2000 monitor is calibrated at a horizontal center position designated by the center of the metal nameplate. The Boa 2000 will rotate equally to the left and to the right from this center horizontal position. The Boa 2000 monitor is calibrated at a vertical position at +90 degrees from horizontal. The factory calibrated points and default travel ranges are shown below. Actual monitor rotation ranges will depend on settings from the customer such as Travel Limits, Keep-Out Zones, and Extended Travel operation.

A left and right Keep-Out Zone are factory set at Elkhart Brass so that the monitor discharge elbow and stream shaper do not contact the horizontal motor and sensor geometry. If the monitor is recalibrated or if these Keep-Out Zones are removed, new Keep-Out Zones or Travel Limits must be set to prevent potential interferences between these parts.

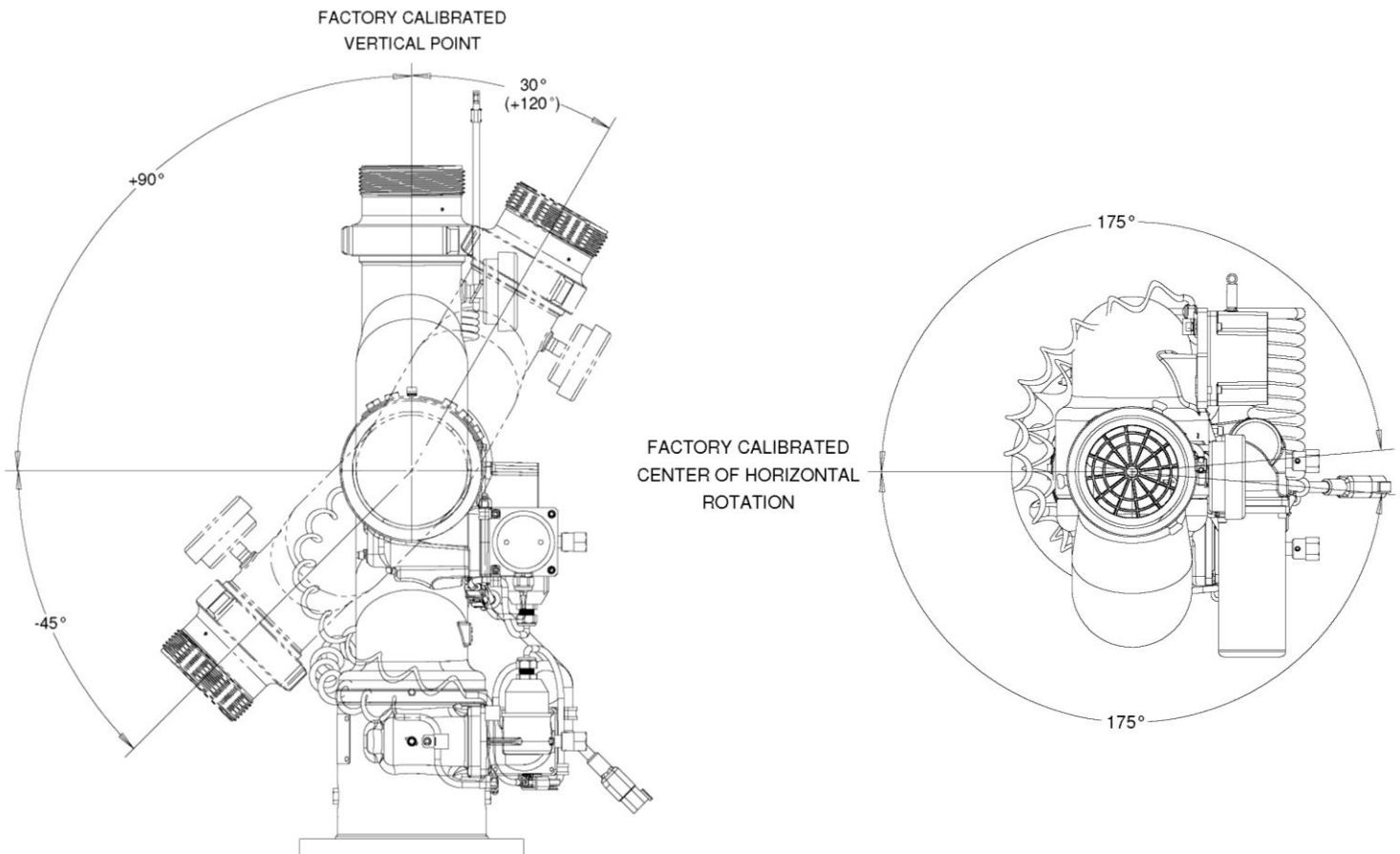

- **Calibrating Horizontal Rotation** – This calibration process will establish the zero (0) horizontal position and allow rotation half to the left and half to the right of the total rotation range specified during system configuration.
  - Put the EXM system into Setup Mode (Reference Part B of Operating Instructions)
  - Using RIGHT & LEFT controls, position the monitor in the location you want to be the center of the allowed range of horizontal travel (i.e. the 0° horizontal position).
  - Press and hold PRESET and then press and release either the LEFT or RIGHT button (On the joystick, hold PRESET and move the stick to the right or left and release). The status LED on the monitor should blink then turn solid.
  - Release the PRESET button. The horizontal axis is now calibrated.
  - Exit Setup Mode and check the monitor’s horizontal rotation limits. The monitor should be checked for possible interference with itself or surrounding objects. Recalibrate the system again if needed.
  
- **Calibrating Vertical Rotation** – The vertical calibration point is factory set at 90° (straight up). This is the position needed when using a Position Feedback Display. This calibration will establish the highest vertical travel point of the monitor and allow rotation in the downward direction the total range specified during system calibration. This differs from the horizontal rotation calibration where the zero point is in the middle of the rotation range.
  - Put the EXM system into Setup Mode (Reference Part B of Operating Instructions)
  - Using the UP & DOWN controls, position the monitor such that it is aimed directly vertical or at the uppermost limit of travel specified during system configuration.
  - Press and hold PRESET and then press and release the UP button (On the joystick, hold PRESET and pull the stick back and release). The status LED on the monitor should blink then turn solid.
  - Release the PRESET button. The vertical axis is now calibrated.
  - Exit Setup Mode and check the monitor’s vertical rotation limits. The monitor should be checked for possible interference with itself or surrounding objects. Recalibrate the system again if needed.



**Caution:** If the vertical calibration is set too far forward, or if proper Keep-Out Zones are not set, the monitor may be allowed to crash into itself at certain points of travel. **BE CAREFUL NOT TO MOVE THE MONITOR INTO OBSTRUCTIONS OR ITSELF** as this will cause the monitor motors to over current. The monitor may need to be manually reversed if this occurs.

## MAINTENANCE INSTRUCTIONS

### Preventive Maintenance

The complete monitor and control system should be inspected during each apparatus check. Careful inspection for damage to the monitor, valve or nozzle is especially important after use of the **Boa 2000** monitor in emergency operations.

- Operate all possible functions to ensure that each works normally
- Flow water to check the nozzle pattern
  - If the pattern is disrupted, clear the debris
  - If the obstruction still remains, remove the nozzle and check for debris lodged between the nozzle stem and body
- During nozzle flow test, inspect monitor swivel joints and water valve for leaks
- Inspect all exposed wiring for signs of damage
- If a Docking Station is used in the EXM system, use a clean cloth to wipe clean the brass contacts on both the Docking Station and any Handheld controllers used with the station.

**Note:** Although grease fittings are provided for the up-down and left-right gear cases, routine greasing should not be necessary. If the monitor is exposed to high level of radiant heat for a prolonged period, it may be possible for the factory grease to thin and run out of the gear cases. In such an event, fresh grease should be applied. It is recommended that Mobilith AW2 grease be used to lubricate the monitor gearing.



**Caution: DO NOT use high pressure spray to clean the EXM System. Using high pressure spray can damage seals and lead to serious damage of electrical components.**

### Understanding System LEDs

- **Monitor Controller LEDs**
  - When the monitor is first powered up all LEDs turn on for approximately 1 second, then only the Power LED remains illuminated
  - When the monitor control box receives a right or left command, the horizontal LED illuminates.
  - When the monitor control box receives an up or down command, the vertical LED illuminates.
  - When the monitor control box receives a fog or stream command, the nozzle LED illuminates.
  - At this time no function illuminates the auxiliary LED on the monitor control box.
  - When in Setup Mode, the blue status LED on the monitor control box will illuminate, and depending on motor speeds, the horizontal, vertical, and nozzle LEDs may or may not be lit.
- **Input Controller LEDs**
  - LEDs flashing above both the open & close buttons indicate that the valve needs to be calibrated.
  - The open LED will flash while the valve is opening whether in auto-travel mode or while holding the OPEN button. The OPEN button LED will stay lit while the valve is in the open position unless the user brings the system into Setup or Programming Modes.

- The close LED will flash while the valve is closing whether in auto-travel mode or while holding the CLOSE button. The CLOSE button LED will stay lit while the valve is in the closed position unless the user brings the system into Setup or Programming Modes.
- The preset LED will flash after the PRESET button has been pressed and will continue to flash until the preset destination is reached. The PRESET button LED will stay lit while the valve is in the PRESET position unless the user brings the system into Setup or Programming Modes.
- While any monitor/valve command button is being pressed on the Panel Mount or Handheld Controllers, the blue power LED will flash rapidly in the upper left corner of the controller.
- When in Setup Mode the yellow status LED in the upper right corner of the Panel Mount and Handheld controllers will illuminate.

- **Docking Station LEDs**

- When the Docking Station has power supplied to it and is not charging a Handheld Controller, the Docking Station LED will be blue and steady.
- When the Docking Station is charging a Handheld Controller at full capacity, the Docking Station LED will be red and flashing at a 3 flash per second rate. This will occur if charging a Handheld whose battery is not near fully charged.
- When the Docking Station is charging a Handheld Controller in trickle mode, the Docking Station LED will be green and flashing. This will occur if charging a Handheld whose battery is almost fully charged.
- When the Docking Station is housing a Handheld Controller that is fully charged, the Docking Station LED will be green and steady.
- If the Docking Station LED is rapidly flashing red (6 flashes per second), this could mean that the Handheld battery pack of the controller being charged is bad. If this occurs, contact an Elkhart Brass representative for further instruction.

## SYSTEM SPECIFICATIONS

### Boa 2000 Monitor - 7451

- Max Flow Rating 2000 GPM (7570 LPM)
- Max Operating Pressure 200 PSI (13.8 BAR)
- Inlet Size 4"-150# Flange
- Outlet Size 3.5" Male NHT
- Travel V: -45° to +120°  
H: L175° to R175°
- Movement Sealed Electric Motors
- Swing Radius 8.9" (360°)
- Stow Height 20"
- Weight 47 Lbs. (21.3 Kg)
- Operating temperature range -40°F to +185°F (-40°C to +85°C)
- Environmental Rating NEMA 4

### Monitor Controller

- Input power 12/24 VDC (11 VDC to 27 VDC)
- Control Communication CAN bus J1939  
2.4 Ghz digital radio frequency (unlicensed)
- Electrical Load See Table 1 Below
- Fuse Rating 40 AMPS (12V) & 20 AMPS (24V)
- RF power output Meets FCC part 15 requirements for license free operation
- Operating temperature range -40°F to +185°F (-40°C to +85°C)
- Environmental Rating NEMA 4
- FCC ID KQL-2510100

### Boa 2000 Motors

Motor (12 VDC)	Left/Right	Up/Down	Nozzle
Run Current	3 A	3 A	0.5 A
Stall Current	27 A	27 A	NA
Current Trip Point	15 A	15 A	4 A

Table 1: Motor Current Specifications

### Panel Mount Controller - 7010

- Input power 12/24 VDC (11 VDC to 27 VDC)
- Electrical Load 0.5 AMPS
- Fuse Rating 1 AMPS (12V) & 0.5 AMPS (24V)
- RF power output Meets FCC part 15 requirements for license free operation  
(Output if applicable)
- Transmitter dimensions 7 17/32" x 3 19/32" X 1 1/8"
- Transmitter weight 0.815 lbs.
- Operating temperature range -40°F to +185°F (-40°C to +85°C)
- Environmental Rating NEMA 4
- FCC ID KQL-2510100

## Handheld Controller - 7015

- Input power Li-Ion 3.7V
- Expected battery life 3.5 hours with continuous RF Transmission
- Real time clock & calendar (RTCC) battery life 2 years without continuous power and 15 years with
- Electrical Load 0.5 AMPS
- Fuse Rating 1 AMPS (12V) & 0.5 AMPS (24V)
- RF power output Meets FCC part 15 requirements for license free operation
- Transmitter dimensions 7 17/32" x 3 19/32" x 2 1/4"
- Transmitter weight 1.2 lbs
- Operating temperature range -40°F to +185°F (-40°C to +85°C)
- Environmental Rating NEMA 4
- FCC ID KQL-2510100

## OEM Interface Module – 7072 & 7073

- Input power 12/24 VDC (11 VDC to 27 VDC)
- Electrical Load 0.5 AMPS
- Fuse Rating 1 AMPS (12V) & 0.5 AMPS (24V)
- RF power output Meets FCC part 15 requirements for license free operation
- Transmitter dimensions 8 11/32" x 6 13/16" x 2 7/16"
- Transmitter weight 2.475 lbs.
- Operating temperature range -40°F to +185°F (-40°C to +85°C)
- Environmental Rating NEMA 4
- FCC ID KQL-2510100

## Valve Controller

- Input power 12/24 VDC
- Electrical Load 10 AMPS
- Fuse Rating 30 AMPS (12V) & 15 AMPS (24V)
- Operating temperature range -40°F to +185°F (-40°C to +85°C)
- Environmental Rating NEMA 6

## EXM CAN Stow Module - 7095

- Input power 12/24 VDC (10 VDC to 30 VDC)
- Electrical Load (@ 23°C) 50 mA @ 24 VDC, 100 mA @ 12 VDC
- Fuse Rating 1 AMPS (12V) & 0.5 AMPS (24V)
- Dimensions 5.24" x 4.68" x 1.42"
- Transmitter weight 1.15 lbs.
- Operating temperature range -40°F to +158°F (-40°C to +70°C)
- Environmental Rating NEMA 4



## J1939 CAN Communication Structure

### Preliminary Configuration for Input Control CAN Settings:

J1939\_SOURCE\_ADDRESS address range for monitors = 0x80-9F, 0xF0-0xF1

(18 monitors supported on a single CAN network, 0xF0 and 0xF1 are reserved)

J1939\_SOURCE\_ADDRESS address range for extenders = 0xD0-DF

J1939\_SOURCE\_ADDRESS address range for input controls = 0xA0-0xBF, 0x0C (0x0C is reserved)

J1939\_SOURCE\_ADDRESS address range for display boards = 0xC0-CB

J1939\_SOURCE\_ADDRESS address range for CAN Stow Modules = 0xCC-CF

### **Transmitter Status** (Used to transfer information about the status of the transmitter.)

Repetition Rate: 100 ms or on change of state

Data Length: 8

Extended Data Page: 0

Data Page: 0

PDU Format: 239 (0xEF)

PDU Specific: Destination Address (In this case source address of the monitor)

Default Priority: 6

Parameter Group Number: 239, Destination Address (0x00EF\*\*)

\*\* will be replaced with the source address of the monitor to be controlled

<u>Start Position</u>	<u>Length</u>	<u>Parameter</u>
0	1 byte	0xFC specifies primary input control message, 0xFE designates secondary input control
1.0	1 bit	1 for Up button pressed, 0 for not pressed
1.1	1 bit	1 for Down button pressed, 0 for not pressed
1.2	1 bit	1 for Left button pressed, 0 for not pressed
1.3	1 bit	1 for Right button pressed, 0 for not pressed
1.4	1 bit	1 for Fog button pressed, 0 for not pressed
1.5	1 bit	1 for Straight Stream button pressed, 0 for not pressed
1.6	1 bit	1 for Aux 1 button pressed, 0 for not pressed
1.7	1 bit	1 for Aux 2 button pressed, 0 for not pressed (logical, no Aux 2 button currently)
2	1 byte	Horizontal Motor Speed (0 to 100)
3	1 byte	Vertical Motor Speed (0 to 100)
4.0	1 bit	1 for Osc/Stow button pressed, 0 for not pressed
4.1	1 bit	1 for Preset button pressed, 0 for not pressed
4.2	1 bit	1 for CAF button pressed, 0 for not pressed
4.3	1 bit	1 for Valve Open button pressed, 0 for not pressed
4.4	1 bit	1 for Valve Close button pressed, 0 for not pressed
4.5	1 bit	1 for Light 1 pressed (ON), 0 for not pressed (OFF)
4.6	1 bit	1 for Light 2 pressed (ON), 0 for not pressed (OFF)
4.7	1 bit	Reserved
5.0	1 bit	1 for auto-close valve, 0 otherwise
5.1-5.7	6 bits	Reserved
6	1 byte	Group Number of Input Controller sending message (1-15)
7	1 byte	Reserved

## Monitor Position Feedback Message

Repetition rate: 100mS  
Data Length: 8  
Extended Data Page: 0  
Data Page: 0  
PDU Format: 255  
PDU Specific: 240  
Default Priority: 6

Parameter Group Number: 255,240 (0x00FFF0) – broadcast message

<u>Start Position</u>	<u>Length</u>	<u>Parameter</u>
0	1 byte	0xFD – Command
1	2 bytes	Horizontal Position Feedback (0000-3600) 0000 corresponds to the left most allowable operating position. 1/10 degree resolution High byte is byte 1, Low byte is byte 2
3	2 bytes	Vertical Position Feedback (0000-3600) 0000 corresponds to straight up when monitor is mounted vertically. 1/10 degree resolution High byte is byte 3, Low byte is byte 4
5.0	1 bit	1 for at left keep out area, 0 for not at left keep out area
5.1	1 bit	1 for at right keep out area, 0 for not at right keep out area
5.2	1 bit	1 for at left programmed limit, 0 for not at left programmed limit
5.3	1 bit	1 for at right programmed limit, 0 for not at right programmed limit
5.4	1 bit	1 at top limit, 0 for not at top limit
5.5	1 bit	1 for bottom limit, 0 for not at bottom limit
5.6	1 bit	1 for in Extended Travel region, 0 for not in Extended Travel region
5.7	1 bit	1 for Extended Travel enabled, 0 for Extended Travel disabled
6.1	1 bit	Power/CAN cable pin 3 state (0 = grounded, 1 = not grounded)
6.2	1 bit	Power/CAN cable pin 4 state (0 = grounded, 1 = not grounded)
6.3-6.7	6 bits	Reserved
7	1 byte	Reserved

## MONITOR AND NOZZLE HYDRAULIC DATA

### Interpreting Flow Data

The following graphs offer the pressure losses for the monitor (and other devices) in terms of Total Static Pressure Drop. This Total Static Pressure Drop can be found by measuring the difference between the static inlet pressure and the static outlet pressure. The static pressure at either of these points can be found using a simple pressure gauge. An illustration of this method can be seen below.

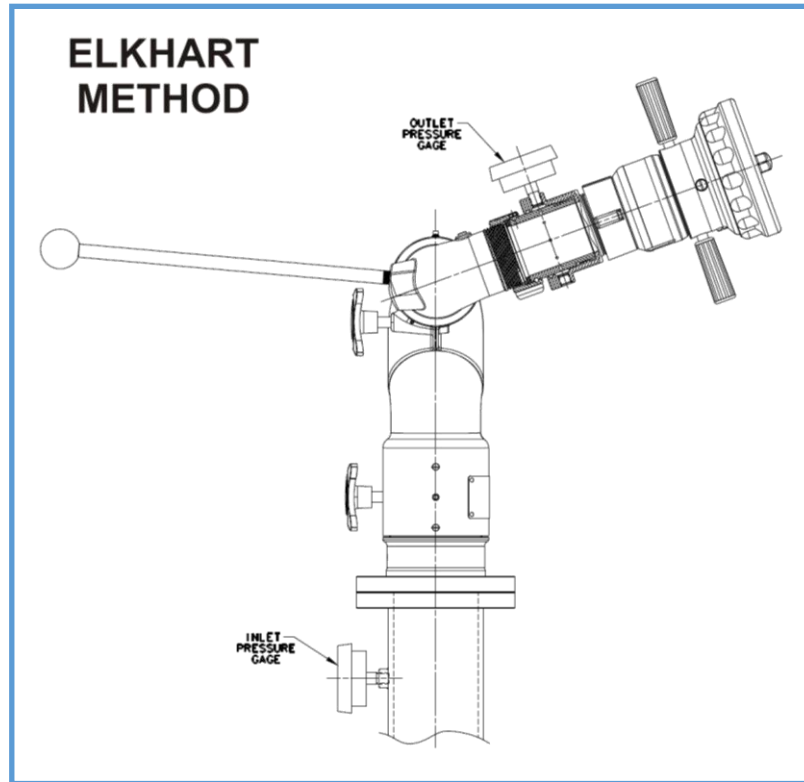

In mathematical terms, the Total Static Pressure Drop is the change in Velocity Pressure plus Friction Loss. The change in Velocity Pressure results from the change in velocity of water caused by the change in the cross section of a waterway. Friction Loss results from the drag and sidewall interference of the water through a device. A simple equation can be seen below.

$$\Delta P_S = H_F + \Delta P_V$$

$\Delta P_S$  = Total Static Pressure Drop  
 $H_F$  = Friction Loss  
 $\Delta P_V$  = Velocity Pressure Loss

In the firefighting industry, the terms Total Static Pressure Drop and Friction Loss tend to be used interchangeably. However, these are significantly different measurements. This misconception could ultimately lead to lower than anticipated performance from equipment. **When designing a system and determining performance, Total Static Pressure Drop is the value that should always be used.** The Friction Loss curve is also supplied in order to make a comparison with competitor products that may only supply Friction Loss curves. If there are any further questions regarding this matter, please contact Elkhart Brass.

### Boa 2000 Static Pressure Drop (4.0" Inlet and 3.5" Outlet)

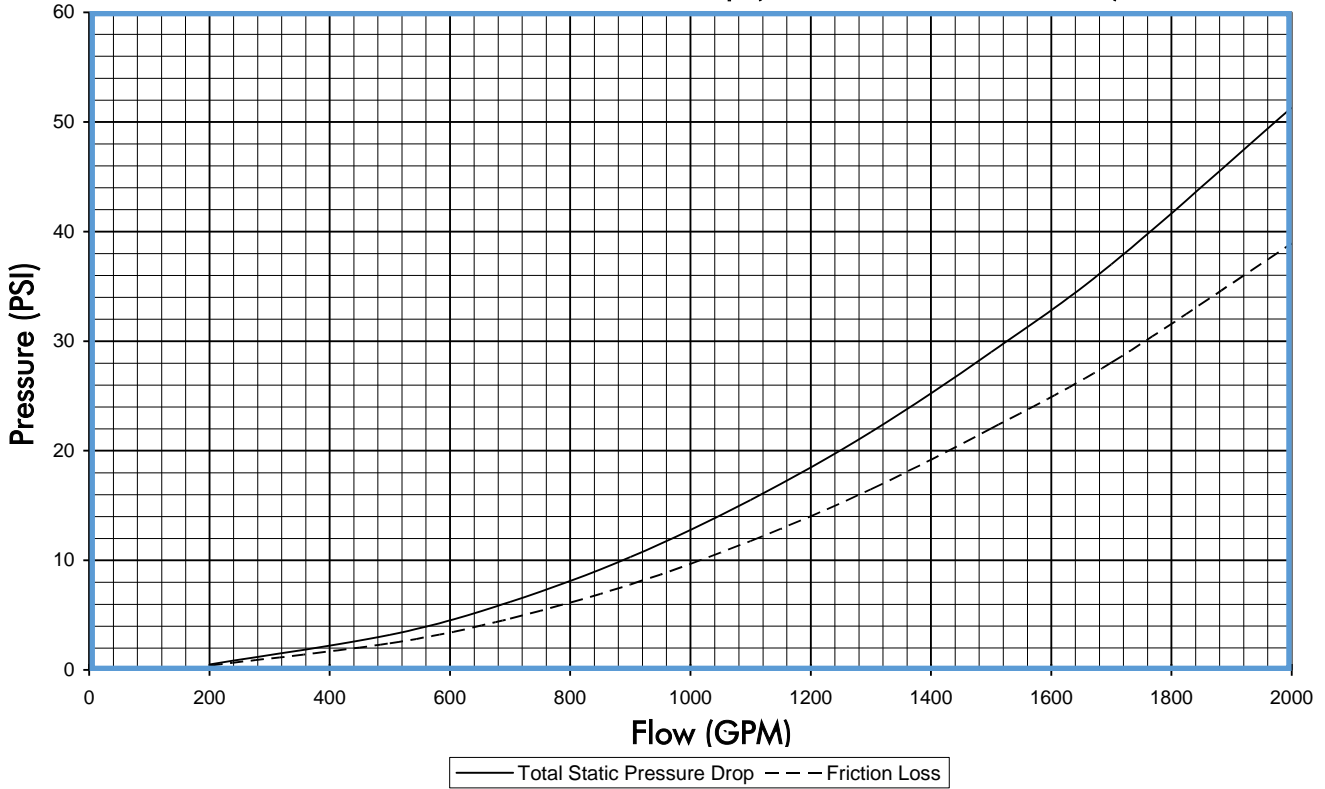

### 284-A & 284-B Stream Shaper Losses

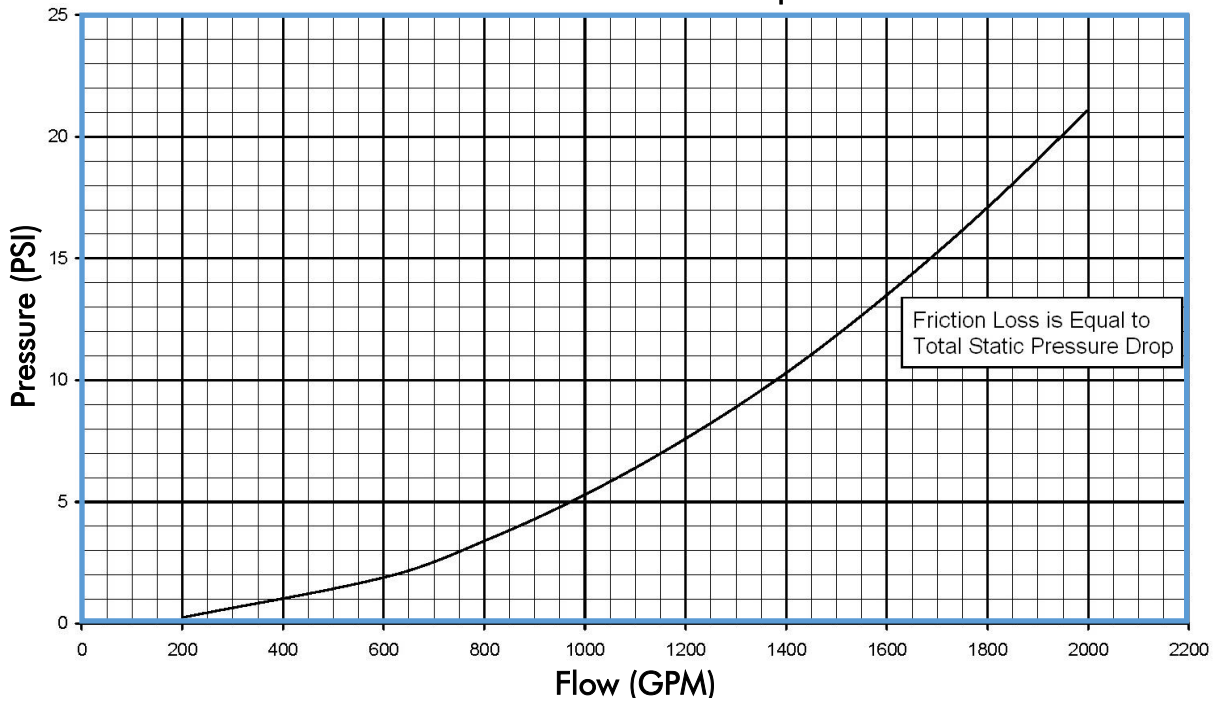

CATALOG NO.	INLET SIZE	STREAM SETTING	NOZZLE DISCHARGE U.S. GPM						EFFECTIVE REACH in FEET					
			NOZZLE PRESSURE PSI						NOZZLE PRESSURE PSI					
			50	60	65	70	75	80	50	60	65	70	75	80
<b>SM-1250E</b>	3.5	SS							110	140	172	220	229	-
		NARROW FOG	385	655	875	1100	1250	-	100	129	132	136	140	-
		WIDE FOG							56	62	68	72	82	-
<b>SM-2000E</b>	3.5	SS							-	-	-	-	240	300
		NARROW FOG	500	850	1250	1500	2000	-	-	-	-	-	125	148
		WIDE FOG							-	-	-	-	90	100

# COMPONENT MOUNTING TEMPLATES

**NOTE:** Pages must NOT be scaled during printing or template size will be scaled incorrectly.

## Panel Mount Controller Mounting Template

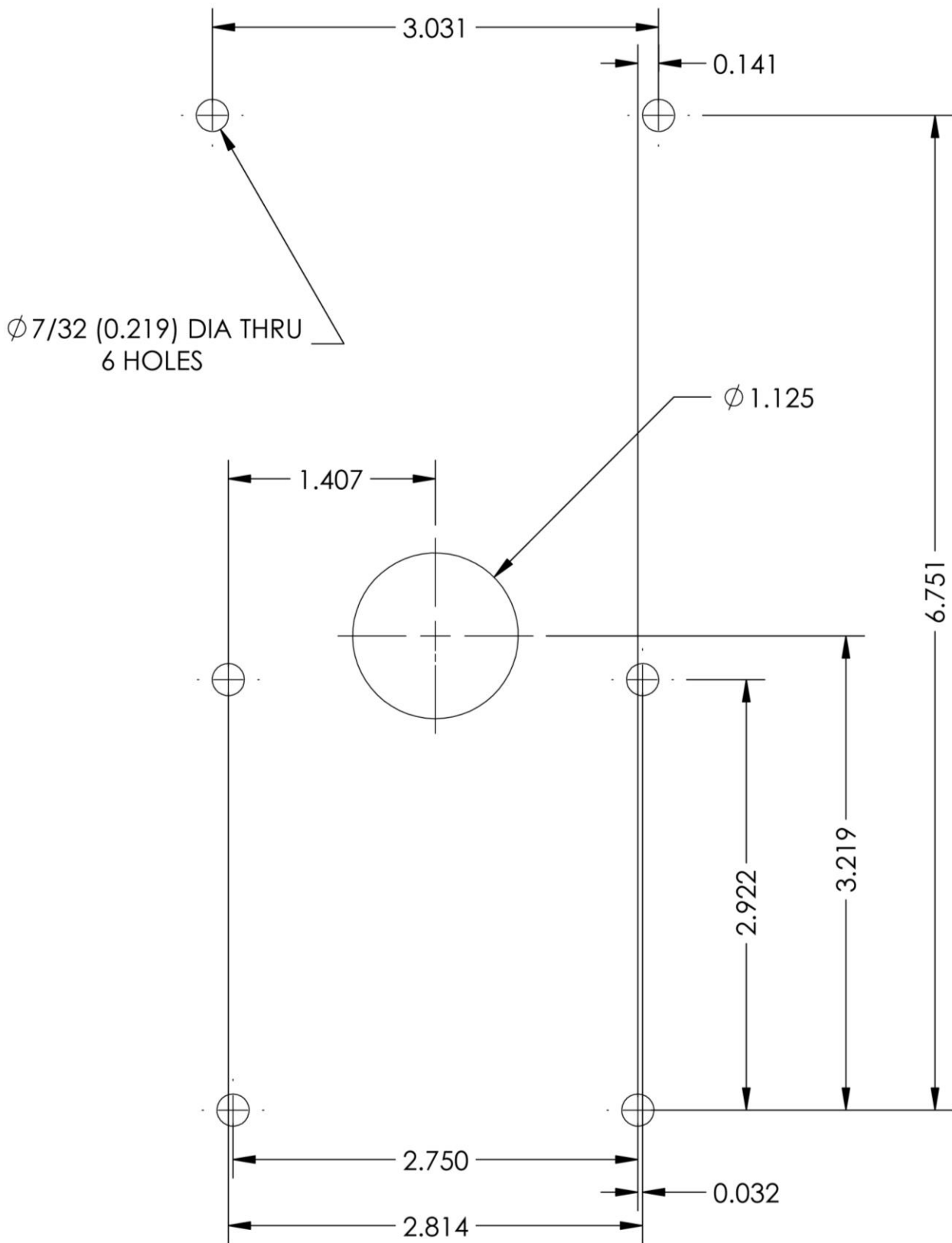

IF YOU CAN SEE THIS TEXT, PLEASE REPRINT THIS PAGE AT 100% (NOT SCALED) FROM THE DIGITAL PDF. DOUBLE CHECK BEFORE DRILLING.

IF YOU CAN SEE THIS TEXT, PLEASE REPRINT THIS PAGE AT 100% (NOT SCALED) FROM THE DIGITAL PDF. DOUBLE CHECK BEFORE DRILLING.

## Docking Station Mounting Template

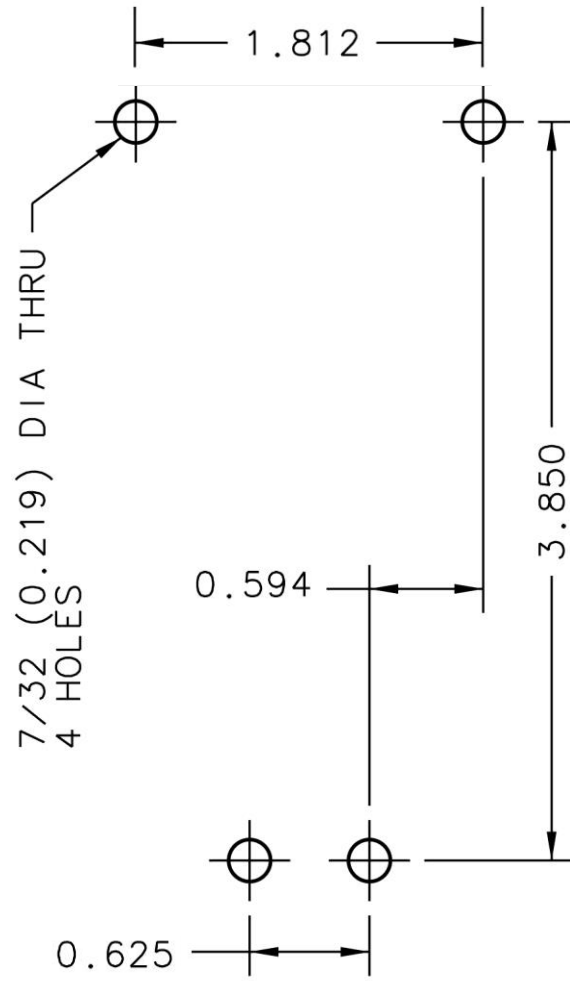

## Position Display Indicator Mounting Template

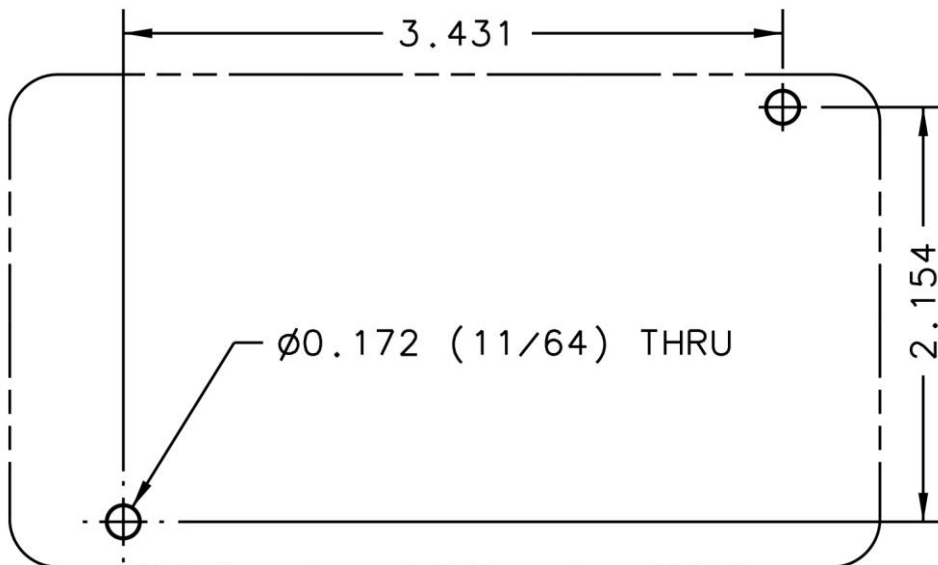

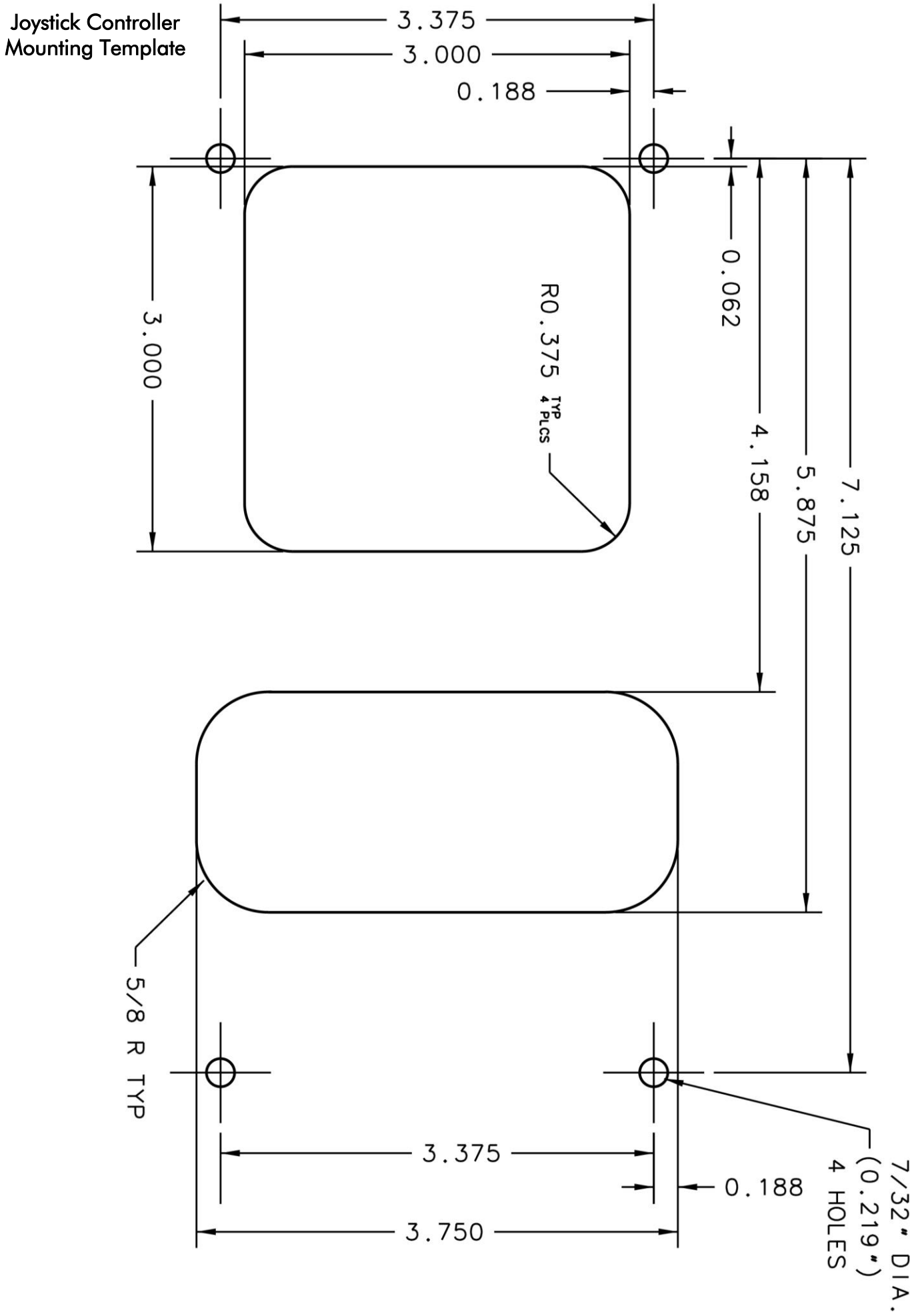

## OEM Interface Module Templates

- 7070/7072 Mounting Template
- 7073 Mounting Template

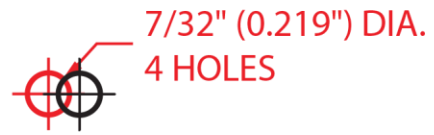
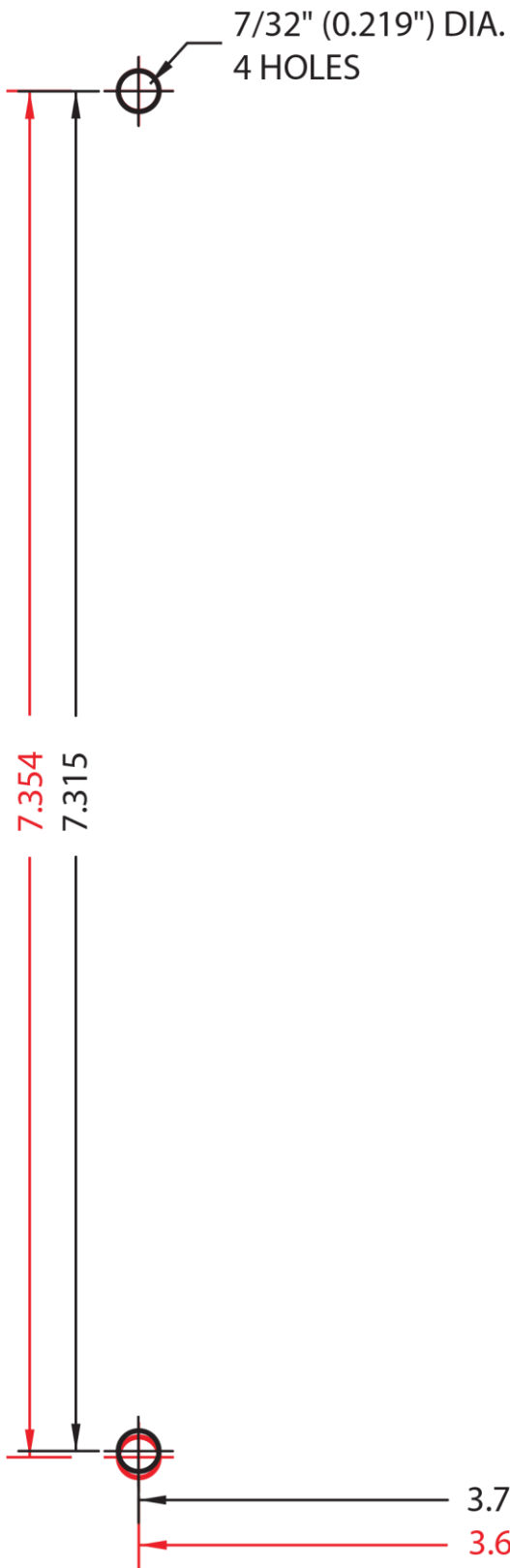

## EXM CAN Stow Module Mounting Template

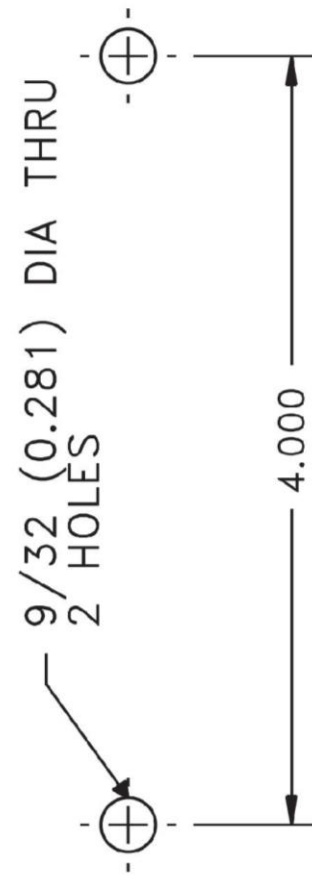







ELKHART BRASS  
PHYSICAL: 1302 WEST BEARDSLEY AVE • ELKHART, IN 46514  
MAILING: P.O. BOX 1127 • ELKHART, IN 46515  
PHONE: 1-574-295-8330 • 1-800-346-0250  
FAX: 1-574-293-9914  
WWW.ELKHARTBRASS.COM

© ELKHART BRASS MFG. CO., INC. 2017

BOA 2000 MONITOR  
INSTALLATION, OPERATION, AND MAINTENANCE INSTRUCTIONS  
98560100 REV. REL

---