

COPPERHEAD



8593-04 Monitor

Installation, Operating, & Maintenance Instructions



9852000 REV A

1-574-295-8330
www.elkhartbrass.com

ELKHART BRASS
FIRE FIGHTING EQUIPMENT A SAFE FLEET BRAND

TABLE OF CONTENTS

PRODUCT SAFETY INFORMATION.....	3
MONITOR CALLOUT DRAWING.....	4
SYSTEM COMPONENTS.....	5
INSTALLATION INSTRUCTIONS.....	8
Installation Step 1: Mount and Wire all System Components	8
Installation Step 2: Communication Address Setup	10
Installation Step 3: RF Settings Setup	11
Installation Step 4: System Programming	13
OPERATING INSTRUCTIONS.....	14
MAINTENANCE INSTRUCTIONS.....	16
SYSTEM SPECIFICATIONS.....	18
MONITOR AND NOZZLE HYDRAULIC DATA.....	19
COMPONENT MOUNTING TEMPLATES.....	21

To view the most current parts list and drawings please visit www.elkhartbrass.com

PRODUCT SAFETY INFORMATION

- All personnel who may be expected to use this equipment must be thoroughly trained in its safe and proper use.
- Before flowing water from this device, check that all personnel (fire service and civilian) are out of the stream path. Also, check to make sure stream direction will not cause avoidable property damage.
- Become thoroughly familiar with the hydraulic characteristics of this equipment, and the pumping system used to supply it. To produce effective fire streams, operating personnel must be properly trained.
- Whenever possible, this equipment should be operated from a remote location. Do not needlessly expose personnel to dangerous fire conditions.
- Open water valves supplying this equipment slowly so that piping fills slowly, thus preventing possible water hammer occurrence.
- After each use, and on a scheduled basis, inspect equipment per instructions in the Maintenance section.
- Any modifications to the electrical enclosures will destroy the NEMA 4 rating and void warranty coverage of the enclosure and all components within.



Important: Before installing and operating provided equipment, read this manual thoroughly. Proper installation is essential to safe operation.

SYSTEM INFORMATION:

MONITOR SERIAL NUMBER: _____

MONITOR ACCESSORIES (NOZZLE GALLONAGE AND TYPE, TYPES OF TRANSMITTERS, WATER VALVE, ETC.):

MONITOR CALLOUT DRAWING

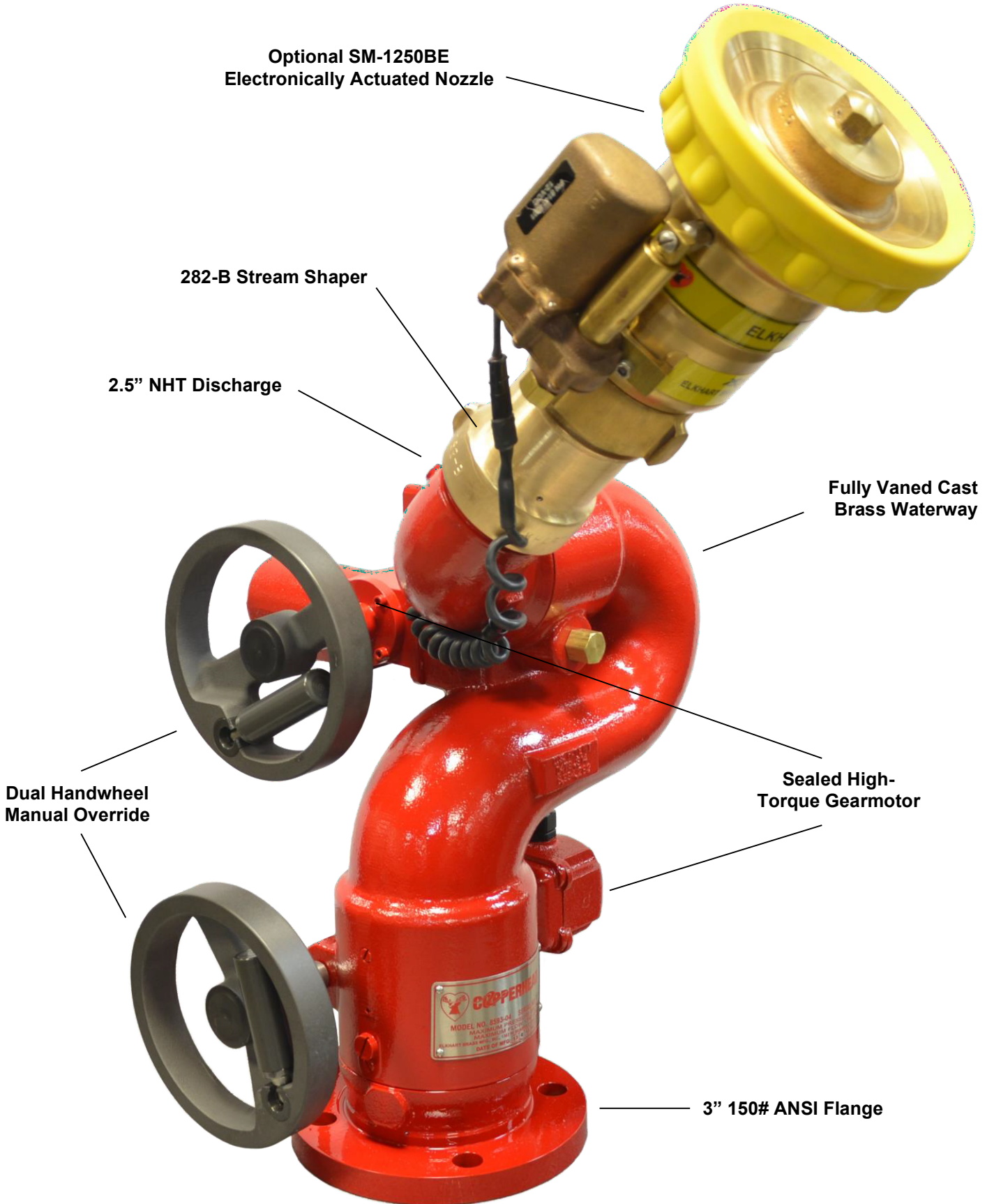

8593-04 Copperhead RF Monitor

SYSTEM COMPONENTS

MONITOR

Copperhead RF Monitor – 8593-04

The 8593-04 Copperhead RF is a brass monitor that contains a central vane inside the waterway to minimize large-scale turbulence and provide superior fire streams. The water supply is provided through the monitor base by a 3" 150# flat faced flange. The discharge nozzle connection is a 2½" National Hose Thread. Nozzle stream direction is controlled by two permanent magnet type gear motors, one controlling rotation about the axis of the water inlet, and the other controlling nozzle elevation and depression.

Max Flow: 1250 GPM (4732 LPM)

Weight: 74 Lbs



8593-04 Copperhead RF
(P/N: 08593041)

 **Caution:** All monitor motors are 12VDC. If using a non-Elkhart nozzle, another 12VDC nozzle should be used, or nozzle control may not function properly.

NOZZLE

Copperhead RF Nozzles –

There are two nozzles recommended for the Copperhead RF.

SM-1250BE

The maximum monitor flow capacity is 1250 gallons per minute. Monitors can be supplied with the SM-1250BE constant pressure (automatic) type master stream nozzle. This nozzle has a flow range of 300 to 1250 gallons per minute at 75 psi and has an electric drive mechanism for RF control of the spray pattern from a straight stream to wide fog.

SM-1250BE; 300 GPM @ 50 PSI – 1250 GPM @ 75 PSI



SM-1250BE (P/N: 03782201)

181 Deluge & 282-B Stream Shaper

Pairing the 282-B stream shaper with the 181 brass smooth bore ensures great stream quality with the flow of a smooth bore nozzle.



181 Deluge (P/N: 66687001) &
282-B (P/N: 03476102)

CONTROL

Handheld RF Controller – 81282001

A sealed handheld RF transmitter contains all the controls necessary for operation of the monitor. The handheld remote allows the operator to direct the monitor from a significantly improved point of view. With the wireless remote, the operator can view the stream from the side and confirm that the stream is hitting its target. Separate push button switches are provided for up, down, left, right, fog, and stream functions. The handheld remote has user selectable frequency and security codes that allow multiple monitors to operate on the same fire ground at the same time. The remote has an automatic power down feature that will shut down the power after 5 minutes of no activity. As an additional power saving feature the radio signal is only transmitted while a button is pushed. The handheld remote case has a NEMA 4 rating.



Primary Panel Mount RF Controller – 81327101

The fixed RF transmitter sends signals to the monitor via an encoded radio signal, requiring no wires between the RF transmitter and the monitor. It is powered by the vehicle electrical system. The faceplate is intended for a flush mount onto the pump panel. Separate sealed push button switches are provided for up, down, left, right, fog, and stream functions. This fixed RF transmitter provides two-button access to the Stow feature. It will override any low-priority controls, allowing the apparatus operator to retain ultimate control over the monitor. Comes with 10 foot coax antenna cable and (1) 90° antenna and (1) straight antenna.



Secondary Panel Mount RF Controller – 81327201

The fixed RF transmitter sends signals to the monitor via an encoded radio signal, requiring no wires between the RF transmitter and the monitor. It is powered by the vehicle electrical system. The faceplate is intended for a flush mount onto the pump panel. Separate sealed push button switches are provided for up, down, left, right, fog, and stream functions. Comes with 10 foot coax antenna cable and (1) 90° antenna and (1) straight antenna.



Caution: Any modification of the Handheld Controller or Panel Mount enclosures will destroy the NEMA 4 rating to that piece of equipment and will void the warranty coverage.

MONITOR ACCESSORY

Primary OEM RF Transmitter – 81353101

The OEM RF transmitter allows the monitor installer to use their switching arrangement while still having the benefit of the W.E.T. It has all of the same features of the Primary Panel Mount RF controller, but has a wiring harness for the installer to connect to the switches. Comes with 10 foot coax antenna cable and (1) 90° antenna and (1) straight antenna.



Secondary OEM RF Transmitter – 81353201

The OEM RF transmitter allows the monitor installer to use their switching arrangement while still having the benefit of the W.E.T. It has all of the same features of the Secondary Panel Mount RF controller, but has a wiring harness for the installer to connect to the switches. Comes with 10 foot coax antenna cable and (1) 90° antenna and (1) straight antenna.



Secondary Switch Box Control – 81549001

This component is a surface mount type switch box with controls for operation of the monitor for use with the OEM secondary RF transmitter. Separate sealed toggle switches are furnished for up-down, left-right, and str-t-fog functions. The box has a NEMA 4 rating. A terminal strip inside the enclosure allows for connection of the control cable, and a watertight strain relief fitting provides for sealing around the cable entry.



Auxiliary Battery Pack – 81492001

A 12-volt, 12 amp-hr. sealed lead-acid battery pack is available to allow operation of the monitor in case of vehicle electrical system failure. These battery packs are also used as a means to minimize the required size of conductors routed. This is accomplished by mounting the battery pack near the monitor, with a small trickle-charge conductor to the battery from the vehicle system.



Caution: Any modification of the enclosures of any of the transmitters or switch box will destroy the NEMA 4 rating, and will void the warranty coverage. Ensure all O-ring and gaskets are properly installed when closing receiver or controller enclosures.

INSTALLATION INSTRUCTIONS

Installation Overview:

Step 1 – Mount and Wire All System Components

Step 2 – Communication Address

Step 3 – Program Settings

Step 4 – System Programming

Installation Step 1: Mount and Wire All System Components



Warning: It is up to the system designer to appropriately handle the open circuit condition of the stow signal. In the open circuit mode there is no source to turn off the stow signal load, which may lead to erroneous signal indications if not handled properly. The stow signal is capable of sinking 250mA maximum. Exceeding this value may blow the internal fuse and the stow output will no longer be able to provide a ground.



Important: Most test lights draw in excess of 1A.

Monitor Mounting –

- **3”-150# Flat Faced Flange:** Attach 3”-150# ANSI pattern companion flange to water supply pipe so that the bolt pattern will allow the monitor to be installed in the straight ahead position. Alignment is correct when the straight ahead position is centered between adjacent flange holes. Attach monitor inlet flange to companion flange on water supply pipe with four (4) 2½” 5/8-11 UNC grade 5, stainless steel bolts & nuts. Seal flange joint with gasket, or suitable flange sealant. Most wafer type butterfly valves have seats that serve as flange gaskets, and separate gaskets or sealant is not required. Apply Loctite 242 or equivalent to bolt threads before tightening nuts. Torque to 60-70 ft-lbs.

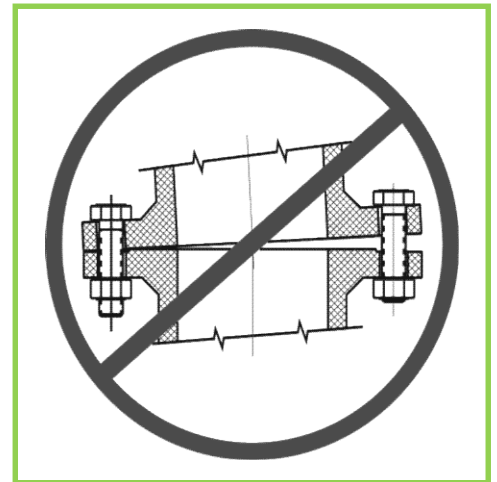

Warning: The piping must be able to withstand a horizontal reaction force of at least 900 lbs at the height of the discharge elbow, and from any angle of rotation that the monitor is capable of turning. Serious injury to personnel and equipment can result from improper installation.



Warning: When installing the monitor on a raised face companion flange, it is critical that the bolts be tightened uniformly to prevent misalignment of the monitor relative to the flange or valve. If the monitor becomes misaligned, the base flange will fracture and fail when the bolts on the “high” side are tightened.

Monitor Wiring –

- Place a 10A fuse between the red lead (pin C) of the monitor and a switched positive power lead on the vehicle. Attach the black lead (pin A) from the monitor base to the vehicle ground.
- The white lead (pin B) is for an optional “Stow Indicator” which could be attached to a relay or LED supplied by the OEM. The circuit switches in a ground, and is limited to 250 mA of current when the monitor is in a non-stowed position.
- All control functions are sent to the monitor via an encoded RF signal from the RF controller, and no control wiring is needed.

Panel Mount RF Controllers –

- Using the Panel Mount RF Controller template in the Component Mounting Templates section, mark the panel cutout and mounting screw locations.
- Cut a rectangular clearance opening and drill four (4) 7/32” holes.
- Insert fixed RF controller case through the panel cutout. Secure the unit to the panel with four (4) #10-32 screws. The length of the screws should be the panel thickness plus 3/16”. The screws supplied are ¼” in length. Apply Loctite 242 or equivalent to screw threads before tightening them.
- The controller antenna is to be mounted using the 10’ antenna cable provided. Locate one of the antennas outside the vehicle compartment, and in a position that provides the least obstructed line of sight to the monitor’s antenna.
- Place a 1A fuse between the red lead of the RF controller and a switched positive power lead on the vehicle. Attach the black lead from the monitor base to the vehicle ground.
- All control functions are sent to the monitor via an encoded RF signal from the RF Controller.

OEM RF Transmitter –

- Place a 1A fuse between the red lead of the transmitter and a switched positive power lead on the vehicle. Attach the black lead from the monitor base to the vehicle ground.
- Connect all of the switch commons to the ground (black) connection.
- Connect each function to a corresponding switch. To operate the function, close function’s switch to ground. Any combination of pushbuttons or toggle switches can be used.
- Power indication can be created by attaching an LED and proper resistance between the VCC (+3V) and ground connections. Max rating for the VCC connection is 250mA.
- The transmitter’s antenna is to be mounted using the 10’ antenna cable provided. Locate one of the antennas outside the vehicle compartment, and in a position that provides the least obstructed line of sight to the monitor’s antenna.

Function	Wire Color
Ground	Black
VCC (+3V) Output	Red
Right	Brown
Down	Orange
Up	Yellow
Left	Green
Stream	Blue
Fog	Violet
Aux 2	Grey
Oscillate	White
Aux 1	White/Black
Stow	White/Brown

Table 2: OEM RF Transmitter switches

Secondary Switch Box Control –

- Using the Secondary Control Switch Box template in the Component Mounting Templates section, mark the mounting holes on panel or bracket.
- Drill two 9/32” diameter holes in panel or bracket.
- Remove ¼-20 screws and lock washers from back of box. Insert screws with lock washers through backside of panel or bracket into mounting holes in box. Tighten screws.

Auxiliary Battery –

- Using the Auxiliary Battery template in the Component Mounting Templates section, mark locations of mounting holes on mounting surface or bracket.
- Drill four (4) 21/64” diameter mounting holes.
- Open hinged cover of battery enclosure by loosening the four screws. Insert one 5/16-18 UNC socket head cap screw from the inside of the enclosure through each of the four (4) mounting holes of the enclosure and into the corresponding holes in the mounting surface or bracket. Assemble nuts and lock washers to each mounting screw, then tighten.
- Plug the female connector of the battery pack into the male connector at the base of the monitor.
- Place a 10A fuse between the red lead (pin C) of the monitor and a switched positive power lead on the vehicle. Attach the black lead (pin A) from the monitor base to the vehicle ground.
- The white lead (pin B) is for an optional “Stow Indicator” which could be attached to a relay or LED supplied by the OEM. The circuit switches in a ground, and is limited to 250 mA of current when the monitor is in a non-stowed position.

Installation Step 2: Communication Address

An RF Controller controls one 8593-04 Copperhead RF monitor. The controller is digitally encoded with a security code ensuring that it does not accidentally control the wrong monitor. The receiver has a matching decoder and security code that instantly decodes and interprets commands. The security code is a 15-bit selectable code that is set on both the remote transmitter and receiver.

The monitors are tested and shipped with a security code based upon the monitor serial number, ensuring each monitor leaves the factory with a unique code assigned to it. The security settings will normally not need to be changed. In the case of a lost transmitter or replaced control board, contact Elkhart Brass.



Danger: Using two W.E.T. monitors with the same security code may cause the inadvertent control of the wrong monitor, resulting in possible property damage and injury to personnel. Using the factory specified codes will help prevent this.



Caution: Do NOT pinch wires when attaching back panel to front panel of the handheld enclosure. Ensure all O-rings and gaskets are properly installed when closing the receiver or transmitter enclosures.



Important: The RF Receiver/Control Module and all transmitter communication addresses have been factory set. They should not require any additional address setup.

Installation Step 3: Program Settings

RF Receiver/Control Module Settings –

The SW1 switch is used for choosing the monitor programming. The SW4 switch has been factory preset for position “E”. This setting allows for slow horizontal travel for the first 2-3 seconds before switching to full speed. Changing to setting “8” allows full speed at all times (see Table 3, reference 4 on page 16).

This monitor has been equipped with mechanical hard-stops to prevent horizontal over-travel (see Installation Step 4: System Programming). The hard-stops are permanently fixed by a stop screw and milled slot in the base. Follow the programming steps to set all travel limits as prescribed in Installation Step 4.

NOTE: The horizontal limits must be set to stop the motors at the location of the hard-stops.

E	8593-04 Copperhead RF – Blinking – Stow Indicator & Slow Start-up
8	8593-04 Copperhead RF – Fast Start-up

NOTE: When setting is changed power to the monitor must be cycled OFF/ON.

If it is set to a value that is not yet programmed, the status indicator LED, DS5 (see Figure 1), will blink rapidly until a valid setting is selected **AND** power is cycled. If SW4 is set to a valid setting but not one of the above positions, unpredictable results will occur.

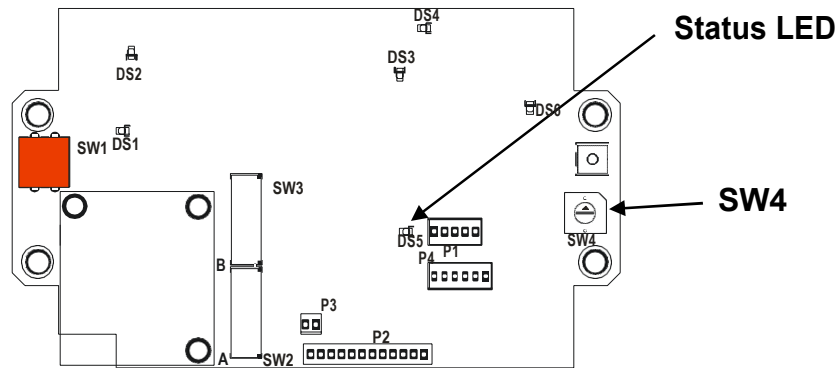
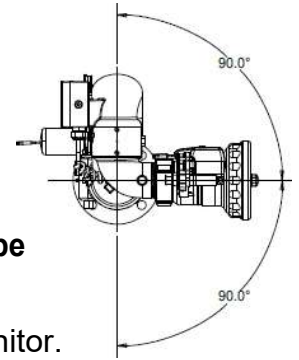

Figure 1: RF Receiver/Control Module Circuit Board

Installation Step 4: System Programming

Programming Horizontal Limits & Stow Position

The 8593-04 Copperhead RF monitor must show H2 limits relative to mounting flange. The monitor is shipped from the factory with horizontal limits at 180° (90° left and 90° right of the straight ahead position). The vertical limits are provided by magnets placed in the monitor at assembly and are not adjustable.



NOTE: All programming steps must be completed. Otherwise the changes will not be stored to permanent memory.

- Remove the cover from the RF Receiver/Control Module located on the monitor.
- Supply power to the monitor.
- Hold the Red Programming Button on the control module board until the programming LED flashes on (approx. 5 seconds).
- To set the left travel limit, rotate the monitor left until it has reached the mechanical stop. Quickly press and release the Red Programming Button. The status LED will flash once to acknowledge the new limit position.
- To set the right travel limit, rotate the monitor right until it has reached the mechanical stop. Quickly press and release the Red Programming Button. The status LED will flash twice to acknowledge the new limit position.
- To set the horizontal stow position of the monitor, move the monitor left or right to the desired position. Quickly press and release the Red Programming Button. The status LED will flash rapidly several times to acknowledge the new stow position. **NOTE: The stow position must be between the right and left limits that were just programmed in the previous two steps. It is not recommended to set the position right at the maximum right or left travel limit.**
- To choose the vertical stow position of the monitor, set switch A position 1 "ON" for stow up, or switch A position 1 "OFF" for stow down (**Receiver only**). **NOTE: The vertical stow position will either be all the way up or all the way down, nowhere in between.**
- Remove power from the monitor for a minimum of 5 seconds. Reapply power and operate the monitor to verify that the travel limits are at the correct positions, and the monitor stows correctly. If not, follow the steps above to reprogram the limits.

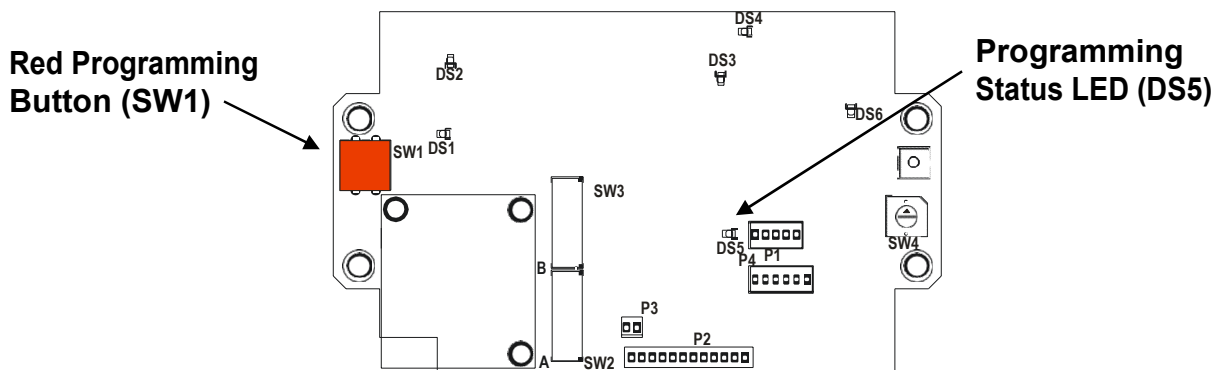

Figure 3: SW1 Programming Button



Caution: To prevent damage to the monitor controller, keep all metallic objects away from the receiver circuit board while it is energized. Ensure all O-rings and gaskets are properly installed when closing receiver enclosure.

OPERATING INSTRUCTIONS

Normal Operation

The 8593-04 Copperhead RF Monitor uses the standard Left/Right, Up/Down, and Fog/Stream commands to provide stream direction and pattern adjustments. With SW4 in position “E”, The controller provides an automatic speed adjustment to allow the user better directional control. During normal operation, the horizontal motor will move slowly for about two seconds before accelerating to full speed. This allows the user to be able to position the monitor quickly but also gives the fine control needed to aim the monitor accurately at a distant target. (SW4 position “8” allows full speed at all times)

- To move the monitor left or right, press and hold the LEFT or RIGHT button until the monitor discharge is in the correct position, or a travel limit is reached. Pressing UP/DOWN or FOG/STREAM while traveling in the horizontal plane will immediately activate full speed motor movement until the monitor stops. Normal operation will resume thereafter.
- To move the monitor up or down, press and hold the UP or DOWN button until the monitor discharge is in the correct position, or a limit is reached.
- To adjust the stream pattern, press and hold the FOG or STREAM button until the desired stream pattern is reached.

Any combination of left or right, fog or stream, and up or down can be used to achieve motion horizontal, vertical, or nozzle commands simultaneously. If the LEFT and RIGHT buttons are pressed at the same time, the monitor will stop all motion. To continue motion, release both buttons and repress the desired direction button. This is also true for the up/down and fog/stream commands.

The handheld remote transmitter has a power saving feature that turns the transmitter power off if no signal is sent for 5 minutes. Press and hold the “ON/OFF” button until the Power LED illuminates to reactivate the transmitter. The “Low Battery” LED will flash slowly when the battery voltage drops below a predetermined level. When the low battery LED flashes rapidly, the batteries are nearly discharged and should be replaced immediately.

NOTE: The SM-1250BE master stream nozzle has a unique ball screw drive that allows motor to “free wheel” at the end of pattern travel in either the straight stream or wide fog positions. No slip clutch or current limiting feature is used with these nozzle drives.

Oscillation Function

The 8593-04 monitors have an automatic left/right oscillation function, which can be used to provide continuous exposure protection with no operator input. The oscillation limits are set using the handheld or truck mount RF transmitters. The motor two-speed feature is disabled during oscillation, as the monitor will oscillate at full speed.

- Position the monitor at either the left or the right limit of oscillation.
- Press and hold the OSCILLATE button.
- Move the monitor to the other limit of oscillation, and release the direction button.
- Release the OSCILLATE button.
- Press and release the OSCILLATE button to engage the oscillation function.

- The monitor will oscillate between the limits until the oscillation button is pressed again. Pressing the left or right button on one of the controllers will also stop the oscillation.

For safety reasons, once oscillation has stopped the oscillation limits need to be reprogrammed before it can be re-engaged. The nozzle fog, stream, and discharge elevation functions can be operated while the monitor is oscillating.

NOTE: It is recommended to set oscillation between the maximum left/right travel limits.

Manual Override

In the event of power failure to the monitor, the monitor may be actuated manually. To operate a function manually, simply rotate the manual override handwheels.

NOTE: Using the manual override handwheels will alter the H2's limit settings.

 **Important: Using the horizontal override handwheel will move travel limits and stow position from the original programmed positions. See Installation Step 4 to reset H2 travel limits and stow position.**

 **Warning: Do NOT use impact drivers to operate the manual override nuts. Serious damage to motor gear heads will occur.**

Storing the Monitor

Elkhart Brass recommends that a stow position be set and the stow routine be utilized to place the monitor in its stowed position after each use.

These monitors have a user selectable stow position (see **Programming Stow Position** section for instructions). After the water supply to the monitor has been turned off, simultaneously press the STOW and FOG buttons on the primary panel mount RF transmitter (**buttons must be held down for a minimum of 3 seconds**). The monitor will automatically rotate horizontally to the stow position previously programmed, and either lower or raise the discharge (depending on the position of switch A position 1 on the receiver board). The optional "stow indicator" will turn off after monitor reaches stow position. The OEM primary transmitter will operate using the same inputs as listed for the primary panel mount controller, provided the necessary switches are wired.

Any directional command (left, right, up, or down) will cancel the stow commence. To stow the monitor, the stow command must be reactivated.

 **Warning: Never activate the stow feature while water is flowing. Serious injury to personnel and damage to apparatus could result.**

MAINTENANCE & INSPECTION

Monitor

Preventive Maintenance

The complete monitor and control system should be inspected during each apparatus check. Careful inspection for damage to the monitor or nozzle is especially important after use in emergency operations, and after extended use in salt water environments.

- Operate all possible functions to ensure that each works normally with each controller.
- Flow water to check the nozzle pattern.
 - If the pattern is disrupted, remove the nozzle and check for debris lodged between the nozzle stem and body, or in the stream shaper inlet. Remove debris.
- During nozzle flow test, inspect monitor swivel joints for leaks.
- With the water off, operate the stow function, looking for any possible obstructions and check the final stow position.
- Inspect all exposed wiring for signs of damage.

Note: Grease fittings are provided for the up-down and left-right rotation joints, routine greasing should be performed to expel water & other contaminants that can get into the rotation joints. If the monitor is exposed to a high level of radiant heat for a prolonged period, it may be possible for the factory grease to thin and run out of the rotation joints. In such an event, fresh grease should be applied. Use Mobilux EP2 or equivalent. Start at one end of travel range and apply grease through the fitting of each joint until fresh grease comes out the joint. Repeat every 30 degrees throughout the full range of travel on each rotation joint. Wipe off any expelled grease when done.



Caution: DO NOT use high pressure spray to clean the monitor system. Using high pressure spray can damage seals and lead to serious damage of electrical components.



Caution: Always check the H2 travel limits and stow position after any repairs to the monitor. It is possible that during repair work the stow position could be moved or lost, and will need to be reprogrammed. If necessary, repeat Installation Step 4.

Understanding System LEDs

- **LED Notations**
 - DS1 – Lights when either nozzle direction is engaged.
 - DS2 – Lights when either of the AUX buttons are pushed.
 - DS3 – Comes on when the UP or DOWN button is pressed.
 - DS4 – Comes on with any horizontal movement.
 - DS5 – See DS5 Status Indicator LED Table on next page.
 - DS6 – Lights when power is applied.

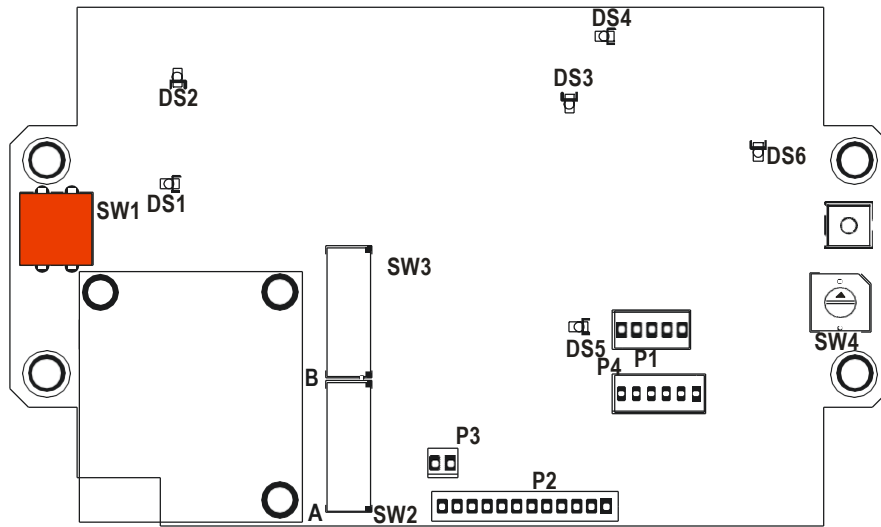

Figure 5: System LED Notations

Table 3: DS5 Status Indicator LED Table

Reference	Indication	Meaning
1	Light comes on for 1 second when monitor stops	Motor has reached stall current and performing normal shutdown.
2	Blinks 3 times after pressing and holding Red Programming Button for more than 5 seconds.	Limit/stow programming sequence initiated. NOTE: This must be completed before normal monitor operation is allowed.
3	Blinks 3 times per second during startup	Visual indication that the controller is initializing – normal operation.
4	Blinks 2 times per second during startup then blinks at ¼ second rate continuously	SW4 in wrong position – must be in position E or 8 for proper 8593-04 monitor operation.
5	Blinks at ½ second rate	Truck battery voltage is <8 volts – light will blink until power is lost or is restored – early power fail (EPF) indication.

Handheld Controller

Battery Type

The handheld controller uses two AA Lithium batteries. The low battery light will illuminate with approximately two hours of transmission time remaining before the batteries are completely discharged. Due to the time-voltage characteristics of rechargeable batteries, this time could be drastically reduced if rechargeable batteries are used.

Battery Replacement

The batteries can be replaced with any standard fresh AA Lithium batteries.

- Turn the controller power off.
- Remove the battery cover.
- Remove both of the old AA batteries.
- Wait 5 minutes, and then install new AA Lithium batteries.
- Replace the battery cover.

SYSTEM SPECIFICATIONS

Panel Mount Controller

- Input power 12/24 VDC (11 VDC to 30 VDC)
- RF power output Meets FCC part 15 requirements for license free operation
- Transmitter dimensions 7 5/8" x 3 7/8" x 2 3/8"
- Operating temperature range -40°C to +65°C, -40°F to +150°F
- Environmental Rating NEMA 4
- FCC ID QT8PTSS2011

Handheld Controller

- Input power 2 AA Batteries (Lithium Recommended)
- RF power output Meets FCC part 15 requirements for license free operation
- Transmitter dimensions 6" x 3 1/4" x 1 3/8"
- Transmitter weight 10 1/2 oz.
- Operating temperature range -40°C to +65°C, -40°F to +150°F
- Environmental Rating NEMA 4
- FCC ID QT8PTSS2011

Receiver

- Power requirements Without Converter Assembly 12VDC (11-14VDC)
With Converter Assembly (11-30VDC)
at the controller under full load
- Electrical Load See Table 4 Below
- Control current 0.07 A (12V)
- Operating temperature range -40°C to +65°C, -40°F to +150°F
- Environmental Rating NEMA 4

Monitor	Left/Right	Up/Down	Nozzle
Run Current*	4.3 A	4.8 A	0.7 A
Stall Current*	14 A	14 A	NA
Current Trip Point*	12.5 A	8 A	4 A

Table 4: Motor Current Specifications

*All current ratings are at 12V

Shock

- 30 G's (55 Hz. @ .2" double amplitude)

Vibration

- 15.5 G's (55 Hz. @ .05" double amplitude) continuous operation

Drop Test

- The handheld controller must meet operating specifications after drop from 1m height onto concrete surface.

Environmental

- All enclosures have a NEMA 4 rating (must withstand a 1" stream of water at 65 GPM from a distance to 10ft. for five minutes with no water entering the enclosure).

COMPONENT MOUNTING TEMPLATES

NOTE: Pages must NOT be scaled during printing or template size will be scaled incorrectly.

Panel Mount Controller Mounting Template

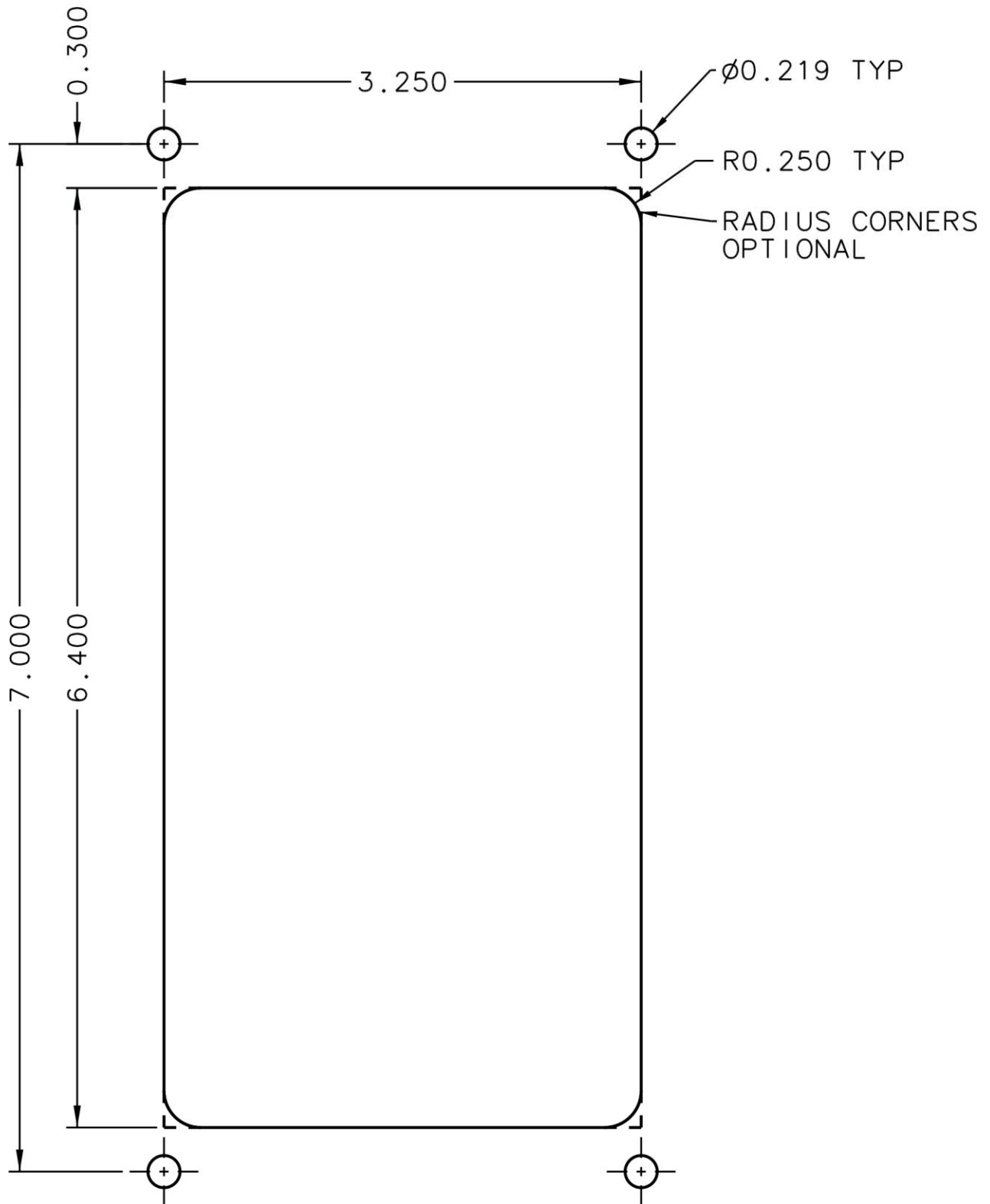

IF YOU CAN SEE THIS TEXT, PLEASE REPRINT THIS PAGE AT 100% (NOT SCALED) FROM THE DIGITAL PDF. DOUBLE CHECK BEFORE DRILLING.

IF YOU CAN SEE THIS TEXT, PLEASE REPRINT THIS PAGE AT 100% (NOT SCALED) FROM THE DIGITAL PDF. DOUBLE CHECK BEFORE DRILLING.

Secondary Control Switch Box Mounting Template

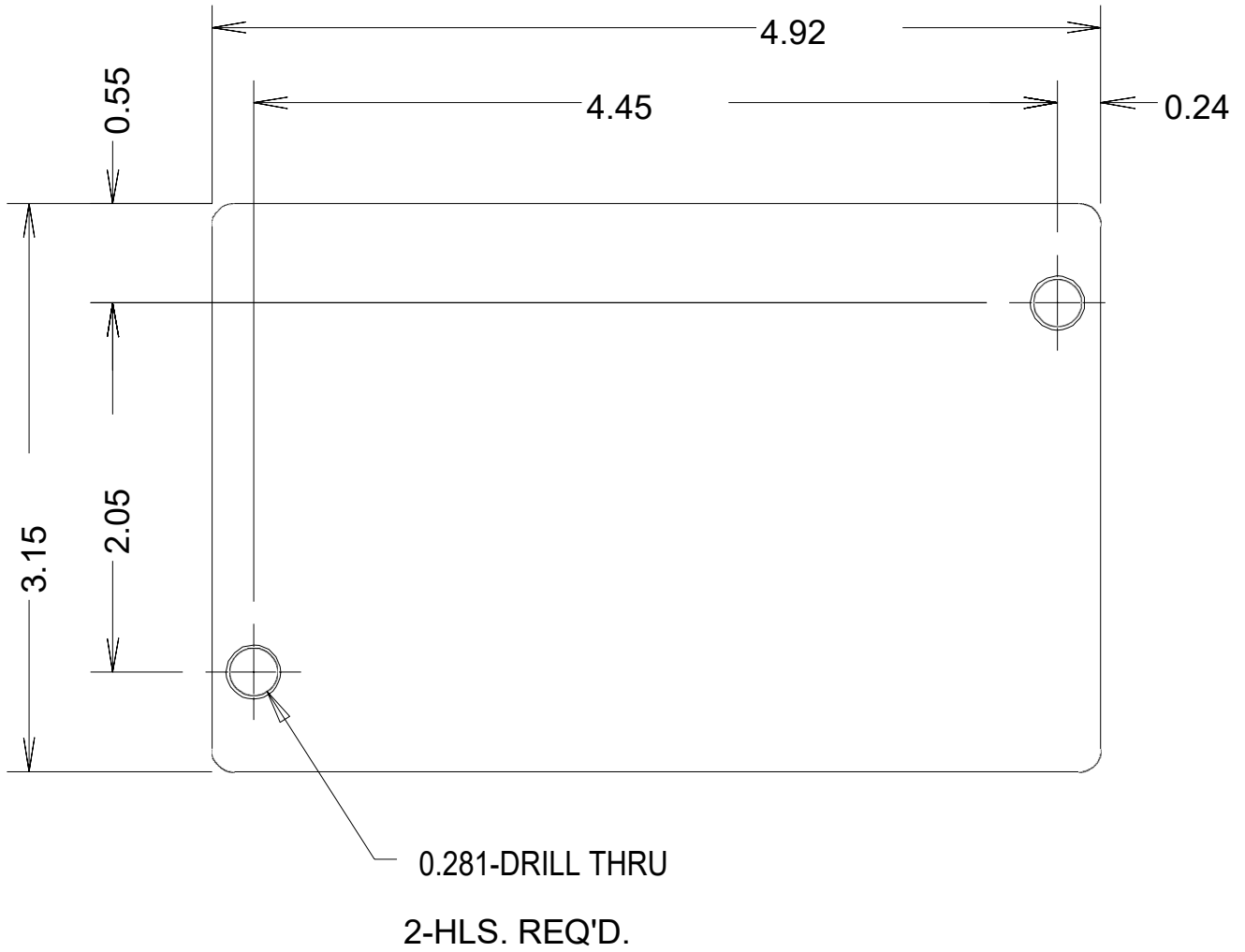

IF YOU CAN SEE THIS TEXT, PLEASE REPRINT THIS PAGE AT 100% (NOT SCALED) FROM THE DIGITAL PDF. DOUBLE CHECK BEFORE DRILLING.

IF YOU CAN SEE THIS TEXT, PLEASE REPRINT THIS PAGE AT 100% (NOT SCALED) FROM THE DIGITAL PDF. DOUBLE CHECK BEFORE DRILLING.

Auxiliary Battery Mounting Layout
THIS IS NOT A TEMPLATE

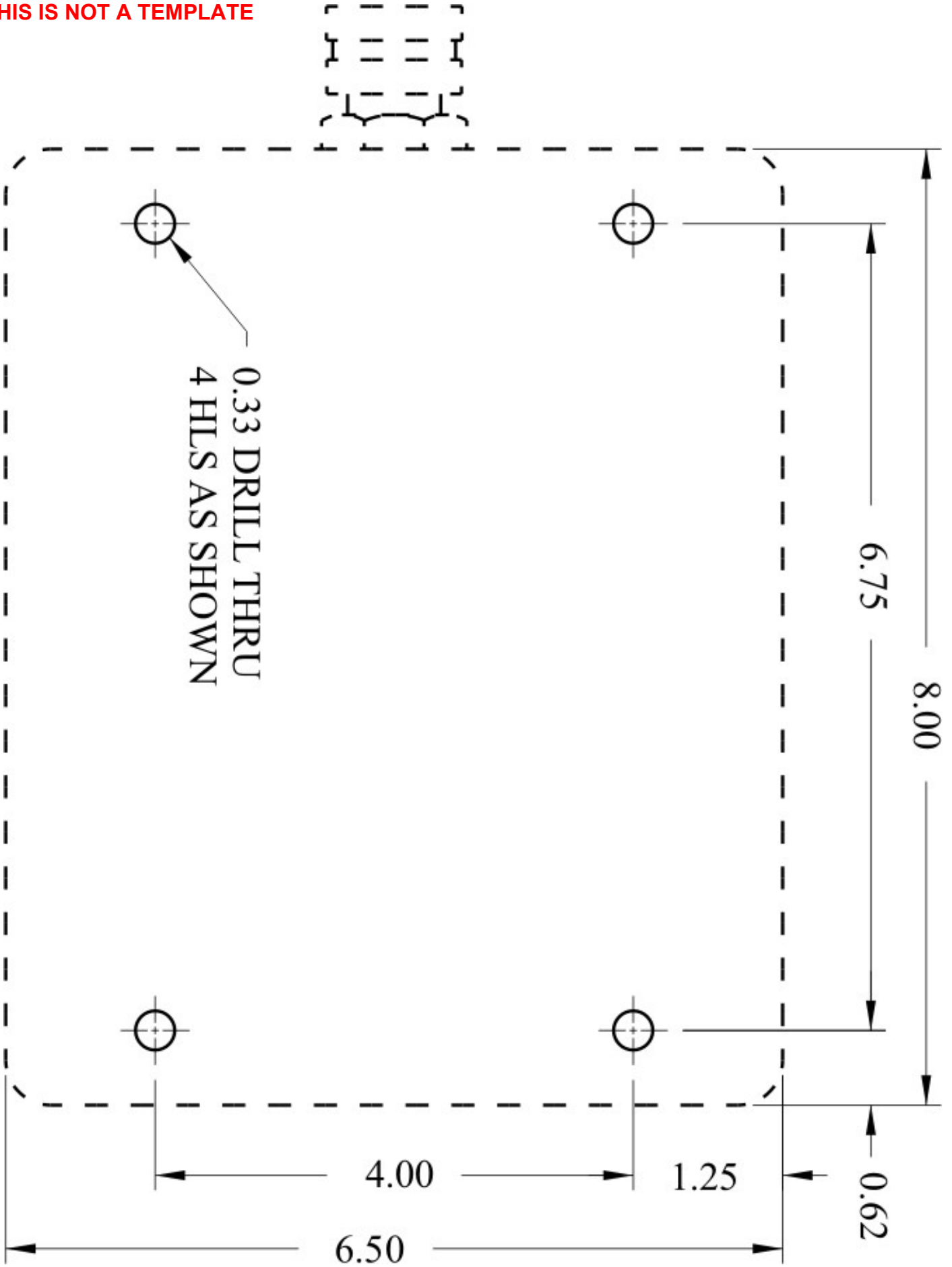



ELKHART BRASS
1302 WEST BEARDSLEY AVE
P.O. Box 1127
ELKHART, IN 46514
PHONE: 1-574-295-8330 • 1-800-346-0250
FAX: 574-293-9914
WWW.ELKHARTBRASS.COM

© ELKHART BRASS MFG. CO., INC. 2014

8593-04 MONITORS
INSTALLATION, OPERATION, AND MAINTENANCE INSTRUCTIONS
98520000 REV. A
