

# ELKHART BRASS

FIRE FIGHTING EQUIPMENT A SAFE FLEET BRAND

## Assembly & Installation Instructions Elkhart Model 299-11 EL Free Standing Elevated Monitor 30' Height

This instruction sheet is to be used in conjunction with assembly drawing 299-11EL (30). Item numbers referenced below are called out on the drawing along with the appropriate weld locations and symbols. Assembly and field fabrication is to be accomplished as follows with tubing components laid out horizontally:

### Assembly:

- (1) Insert lower end of Upper Waterway Weldment Sub-Assembly (Item 18) into the upper end of Lower Waterway Weldment Sub-Assembly (Item 22) for a length of twelve inches.
- (2) Weld upper and lower waterway sections together by making continuous 3/8" bevel weld at top end of Lower Waterway Weldment Sub-Assembly (Item 22).
- (3) Remove and discard the thread protector (cap) and slide Lower Horizontal Drive Sleeve Assembly (Item 23) over waterway section previously welded. Grinding of weld made in step 2 above may be necessary in order to provide clearance for bushing in the lower end of the horizontal drive sleeve. Slide this sleeve as far as possible toward flanged end of waterway.
- (4) Slide Upper Horizontal Drive Sleeve (Item 17) over waterway tubing until the end with the 4 holes is far enough beyond the 3" NPT male thread on the waterway tube to allow the Monitor Sub-Assembly (Item 16) to be installed.
- (5) Install the Monitor Sub-Assembly (Item 16) onto Upper Waterway Weldment Sub-Assembly (Item 18), by wrenching Monitor Base onto Upper Waterway Weldment. Apply a suitable pipe joint sealant compound on the pipe threads and use a strap or chain wrench to tighten the monitor base onto the waterway tube. Remove the grease fitting from the base of the monitor.
- (6) Slide Upper Horizontal Drive Sleeve (Item 17) toward monitor so that the upper end of Drive Sleeve slides over the monitor lower swivel joint. Align two of four holes in Drive Sleeve with the two tapped holes in monitor swivel joint. Secure the upper drive sleeve to monitor swivel joint using the two 3/4-16 x 1.00 bolts (Item 19) from the loose parts in the Ziploc bag. Secure the bolts with Loctite #262. Reinstall grease fitting.
- (7) Remove and discard the two 1" hex head bolts and washers (used to protect the threaded handle attachment bushings) in the Lower Drive Sleeve (Item 23) and install the control arm & vertical lock assembly #81310001 as shown on drawing.

- (8) Rotate Lower Horizontal Drive Sleeve (Item 23) to align Vertical Control Handle with monitor discharge port as shown on drawing and move the Lower Drive Sleeve towards the Upper Drive Sleeve until the bottom of the Upper Drive Sleeve is approximately two inches inside the Lower Drive Sleeves socket. Make sure the alignment is still good and support the Horizontal Drive Sleeves as necessary to maintain alignment of the sections prior to welding.
- (9) Join upper and lower sections of Horizontal Drive Sleeve (Item 17 & 23) by making continuous 1/8" bevel weld at top end of lap joint sleeve. When possible clean weld and unpainted areas and cover with an etching primer and 2 coats of RAL3003 red urethane enamel.
- (10) Attach the vertical control cables (Item 15) to monitor and control arm using the threaded links and turnbuckles as shown on drawing. Secure the threaded link threads with Loctite #242. Adjust cables so that handle is parallel to monitor discharge centerline.
- (11) Attach nozzle to monitor discharge and tighten securely. If adjustable fog nozzle is used, follow the nozzle installation instructions and attach pattern control cable to nozzle.
- (12) When raising the monitor assembly, **DO NOT** attach cable or sling the monitor section of the assembly. This portion of the assembly is not designed to support the weight of the long riser, and damage or failure could result.

**Installation:**

The supply pipe and companion flange configuration to which the 299-11 EL monitor is installed must be supported to withstand a bending moment of 23,000 FT/LBS applied to the flange face. A forged steel flange and steel pipe with adequate support are recommended. **DO NOT** use a cast iron companion flange or cast iron pipe. Join monitor base flange to companion flange using 3/4"-10 SAE Grade 8 bolts and nuts. Use a 1/16" thick ring gasket designed for use with steel flanges. Torque flange bolts to 260 FT/LBS (Dry).

**\*\*\*\*IMPORTANT\*\*\*\***

**DO NOT** exceed the following maximum allowable flow rates at 100 PSI nozzle pressure:

<u>Monitor Heights</u>	<u>Max. Flow at 100 PSI NP</u>	<u>Maximum Pressure At Base Flange</u>	<u>Calculated Deflection of Nozzle at Maximum Flow</u>
30 Ft.	750 GPM	139 PSI	12.54 inches

Pressure and flow characteristics of water supply must be determined prior to monitor installation, and a restricting device, such as an orifice plate, installed between flanges to limit flow and pressure to appropriate values as indicated above.

## **Operation:**

Familiarize all personnel that will be using this equipment with the operation of all the monitor's locks and controls before flowing water. The water supply to the monitor should be increased slowly to prevent whipping of the monitor due to nozzle reaction.

**Horizontal and Vertical locks:** The monitor should **always** be locked in position when it is to be left unattended. The horizontal travel is locked and unlocked using a friction lock operated by hand wheel assembly (Item 14). Turn the hand wheel assembly clockwise to lock the monitors horizontal travel and counterclockwise to unlock it. The vertical travel can be locked in position using the friction lock on the right hand side of the control arm. To lock the monitors vertical travel turn the lock clockwise using the handle shaft with the knob on the end (Items 1 & 2). Turn the lock counterclockwise to unlock the vertical travel of the monitor. **Always make sure both locks are engaged before flowing water.**

**Controlling Horizontal and Vertical movement:** The monitor movement is controlled using the hand grip (Item 16) located on the end of the control arm assembly. Firmly grasp the hand grip with one hand and release the vertical and horizontal locks with the other. Only release the locks enough to allow movement in all directions. Pushing down on the hand grip will raise the discharge of the monitor and lifting will lower the discharge. Pushing the hand grip to the left will move the discharge of the monitor to the right and pushing the hand grip to the right will move the discharge of the monitor to the left. **Do not release the monitor controls without engaging both the horizontal and vertical locks first.**

## **Maintenance:**

The monitor should be moved through its entire range of motion and inspected for proper function of all locks and controls monthly. The monitor should be greased through the two fittings located on the monitor assembly (Item 15) every three months. General purpose petroleum grease should be used. Maintain paint as dictated by the environment.

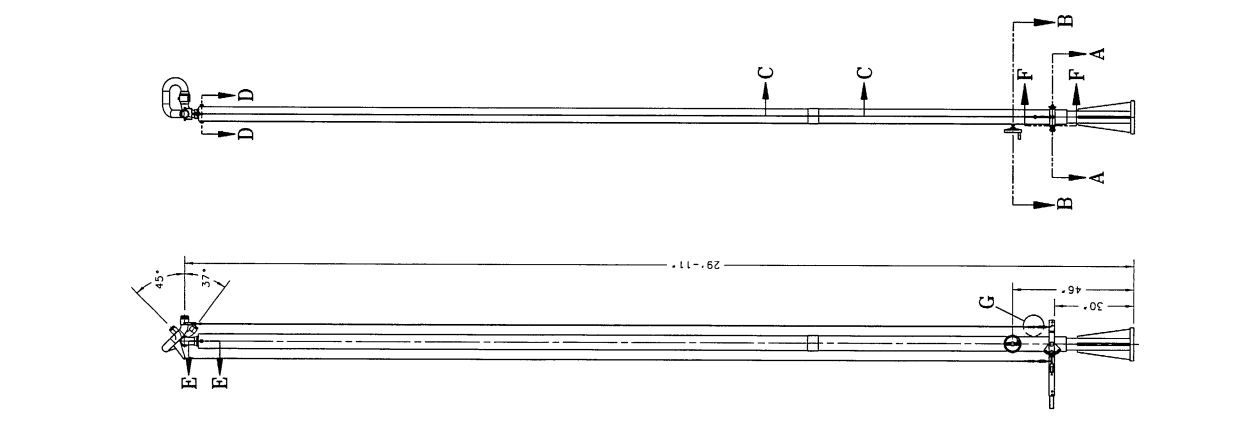
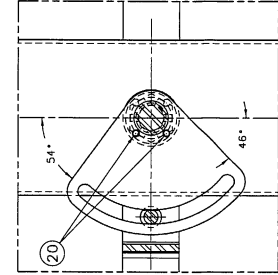
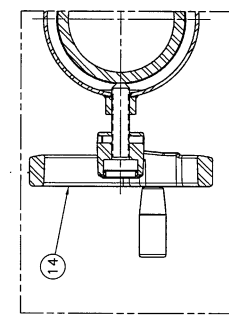
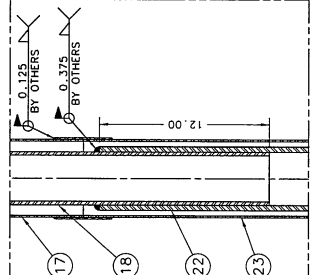
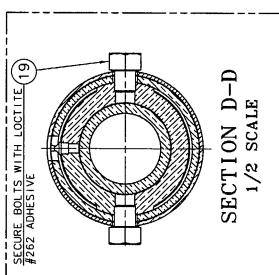
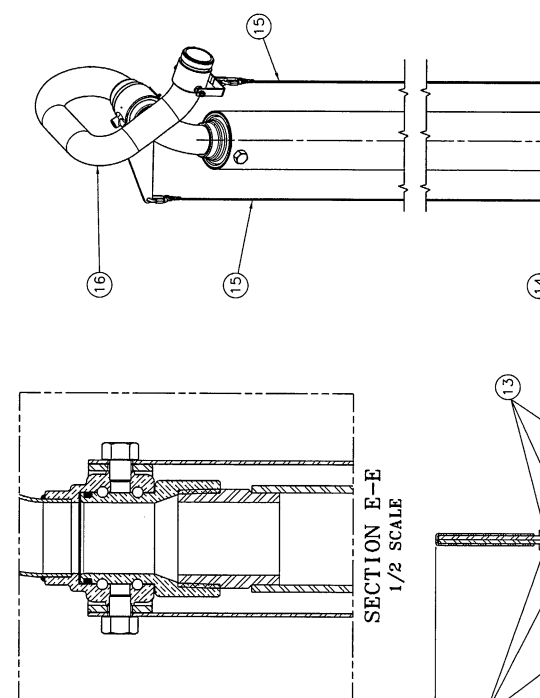
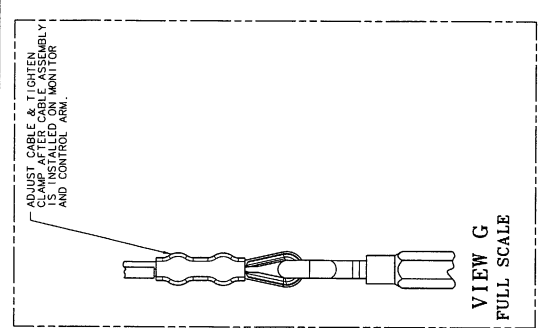

QTY	ITEM NUMBER	DESCRIPTION
1	22	B1611001 LOWER W/W WELDMNT (30" FF) (99192401) 6"-300# FF FLANGE
1	22	B1610001 LOWER W/W WELDMNT (30" FF) (99192301) 6"-300# FF FLANGE
1	26	B2609000 STUD-THREADED 1"-14
1	25	H4242100 LABEL - SERIAL NUMBER
2	24	B1215100 NUT - HEX (0.312-8) SS
1	23	B0704000 SPEC. W/OUT COIL SPRING
1	21	B3629000 GRIP - HAND (RUBBER)
1	20	B1269000 PIN - ROLLER 3/8" DIA. X 1.689" L. (303) AL. HEK
2	19	B1680000 BUSH - HEK
1	18	B0700000 UPPER WATERTIGHT WELDMNT
1	17	B0702000 UPPER DRIVE SLEEVE WELDMNT
1	16	B0701000 299-11EL MONITOR ASSEMBLY
1	15	B0709001 CONTROL CABLE ASSEMBLY (30")
1	14	B0717000 HORIZ. LOCK HANDLE ASSY
1	13	B7484000 NUT - HEX (0.312-8) SS
5	12	B6555001 BRACKET - CONTROL (LEFT)
1	11	B2049000 PIN - ROLLER 3/8" DIA. X 1.689" L. (303) AL. HEK
1	10	B7481200 NUT - HEX (0.312-8) SS
1	9	B1059000 SCREW - MACH. (303) AL. HEK
5	8	B1245001 CONTROL ARM WELDMNT
1	7	B7851001 BOLLT - PIVOT 5/8"
1	6	B2586000 PLATE - LOCK 5/8"
1	5	B6637001 HUB - LOCK 5/8"
1	4	B6543001 SHAFT - LOCK 5/8"
1	3	B8843000 CONTROL ARM (FRAME #144430)
1	2	B6362001 SHAFT - HANDLE 5/8"
1	1	A2022000 KNOB - HANDLE

REV.	DATE	BY	CHKD.	DESCRIPTION
B	10/28/2009	WKS	WKS	REVISED FOR CONFORMANCE WITH SDRC
A	10/28/2009	WKS	WKS	RELEASED TO PROD.
1	10/28/2009	WKS	WKS	REVISED FOR CONFORMANCE WITH SDRC

REV.	DATE	BY	CHKD.	DESCRIPTION
B	10/28/2009	WKS	WKS	REVISED FOR CONFORMANCE WITH SDRC
A	10/28/2009	WKS	WKS	RELEASED TO PROD.
1	10/28/2009	WKS	WKS	REVISED FOR CONFORMANCE WITH SDRC

ELKHART BRASS WORKS CO., INC.  
 FREE STANDING ELEVATED MONITOR ASSEMBLY  
 30 FT MONITOR 6"-300#  
 SCALE: 3/4" = 1' DATE: 10/28/2009  
 DRAWN BY: WKS  
 CHECKED BY: WKS  
 DATE: 10/28/2009  
 SDRC (SOLIDWORKS) RELEASED FOR CONFORMANCE WITH SDRC

NOTES:  
 (1) 30 FOOT MONITOR MAX. FLOW IS 750 G.P.M.  
 (2) THIS MAXIMUM FLOW RATE TO BE DEVELOPED WITH A MAXIMUM NOZZLE PRESSURE OF 100 P.S.I.

29-111

24.20 REF

1.375 FROM FACE OF BUSHING

29-111

29-111