



ELKHART BRASS MFG. CO., INC.

1302 WEST BEARDSLEY AVENUE • P.O. BOX 1127 • ELKHART IN 46515 • (574) 295-8330 • FAX (574) 293-9914

Installation, Operating, & Maintenance Instructions



Model 8297 RF

Stinger[®] RF

Break-Apart Deck Gun/Portable Radio
Controlled Monitor & Accessories

Table of Contents

I. Product Safety.....	1
II. SYSTEM FEATURES.....	2
III. SYSTEM COMPONENT DESCRIPTIONS.....	4
A. 8297 RF Upper Monitor.....	4
B. 8298 RF Deck Mount Adapters	7
C. Portable Bases	7
D. 8297MB-RF Storage Bracket.....	7
E. RF Transmitters	8
81282001 Handheld RF Transmitter (Figure 8)	8
81327111 Panel Mount Primary Transmitter	8
81353101 OEM Primary Transmitter	8
F. AC to DC Battery Charger.....	8
IV. Control System Specifications.....	10
V. Installation Instructions.....	11
A. 8298F RF Deck Mount Adapter.....	11
B. 8298P RF Deck Mount Adapter.....	12
Power Cable Wiring.....	12
81327111 Panel Mount Transmitter	13
81353101 Fixed OEM Supplied Switches.....	14
C. Communications Address	14
VI. Operation	15
A. Deck Gun Mode.....	15
1. Attachment and Operation	15
2. Monitor Removal from base	15
B. Portable Monitor Mode	16
C. Normal Operation.....	17
D. Oscillation Function.....	18
E. Manual Override.....	18
F. Power Switch	19
VII. Maintenance	21
A. Preventive Maintenance Procedures for Stinger RF Upper Assembly	21
Preventive Maintenance.....	21
After Each Use:.....	21
As Needed:.....	22
B. Maintenance Procedures for Stinger RF® Bases	22
After Each Use:.....	22
As Needed:.....	23
Understanding the Controller LEDs	23
Handheld Transmitter	23
Battery Type.....	24
Replacing the Battery.....	24
VIII. Monitor & Stream Shaper Hydraulic Data	24
Interpreting Flow Data.....	24

I. PRODUCT SAFETY



Important:

Before installing and operating this equipment, read & study this manual thoroughly. Proper installation is essential to safe operation. In addition, the following points should be adhered to in order to ensure the safety of equipment and personnel:

- All personnel who may be expected to use this equipment must be thoroughly trained in its safe and proper use.
- Before flowing water from this device, check that all personnel (fire service and civilian) are out of the stream path. Also, check to make sure stream direction will not cause avoidable property damage.
- Become thoroughly familiar with the hydraulic characteristics of this equipment, and the pumping system used to supply it. To produce effective fire streams operating personnel must be properly trained.
- Open water valve supplying this equipment slowly, so that piping and hose lines fill slowly, thus preventing possible water hammer occurrence.
- After each use, and on a scheduled basis, inspect equipment per instructions in section VII.
- Always determine that latch pins are fully engaged (see Figure on pg. 15).
- The maximum monitor flow capacity is 1250 gallons per minute with most base adapters (the clappered Siamese inlet is rated at 1000 GPM).
- Always secure the monitor with the safety strap in portable mode.
- Never attempt to move the portable monitor while flowing water.
- Whenever possible, this equipment should be operated from a remote location. Do not needlessly expose personnel to dangerous fire conditions.
- Always inspect the ground spikes for damage after each use.
- Any modifications to the electrical enclosures will destroy the NEMA 4 rating and void warranty coverage of the enclosure and all components within.



Warning: X-Streams are extremely powerful. Therefore, great care must be taken in directing such streams to avoid injury to personnel and unwanted damage to property.

II. SYSTEM FEATURES

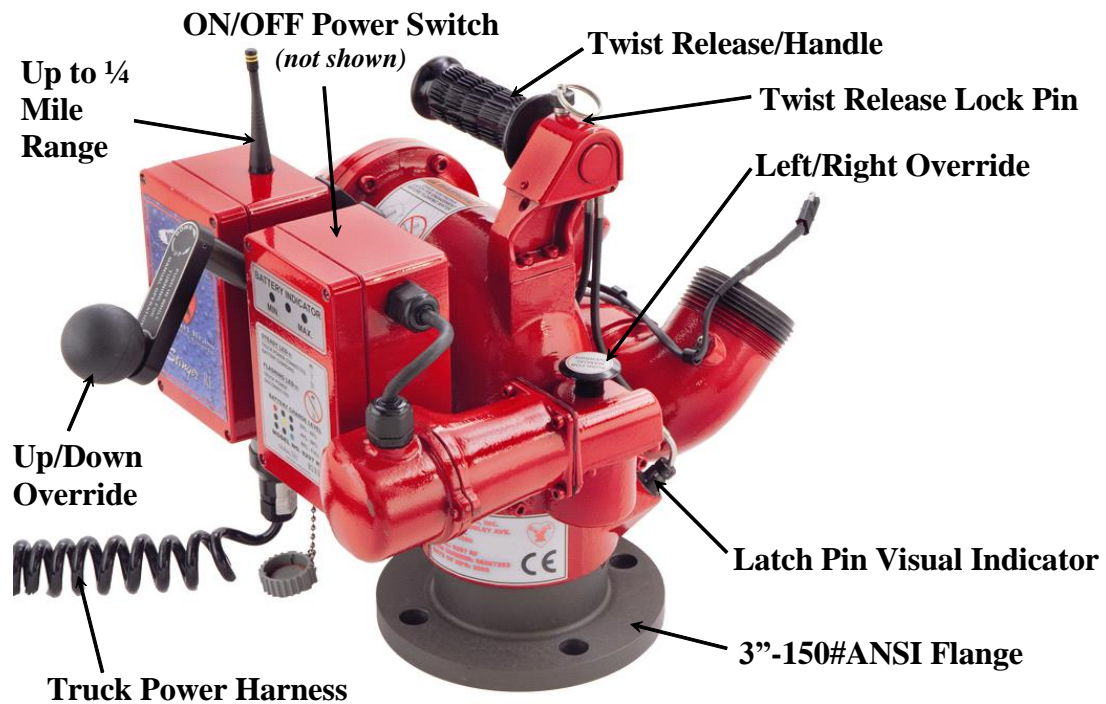
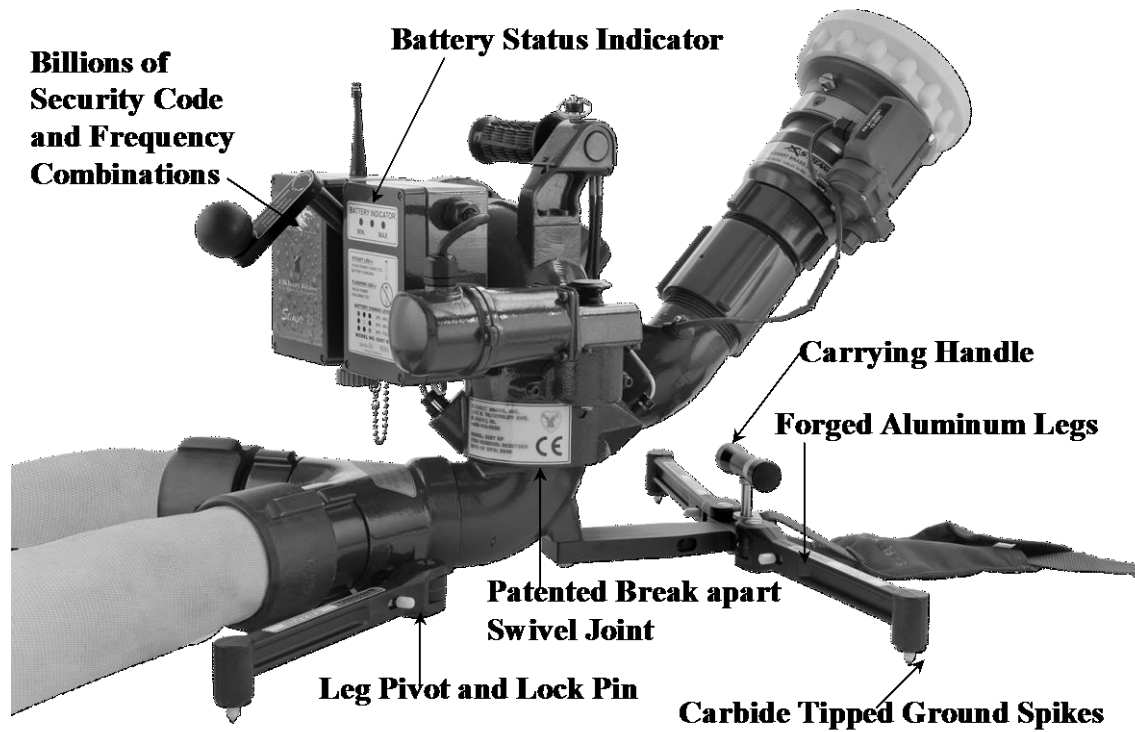

Figure 1
Stinger RF on 2-Inlet Portable Base and on Deck Mount Base

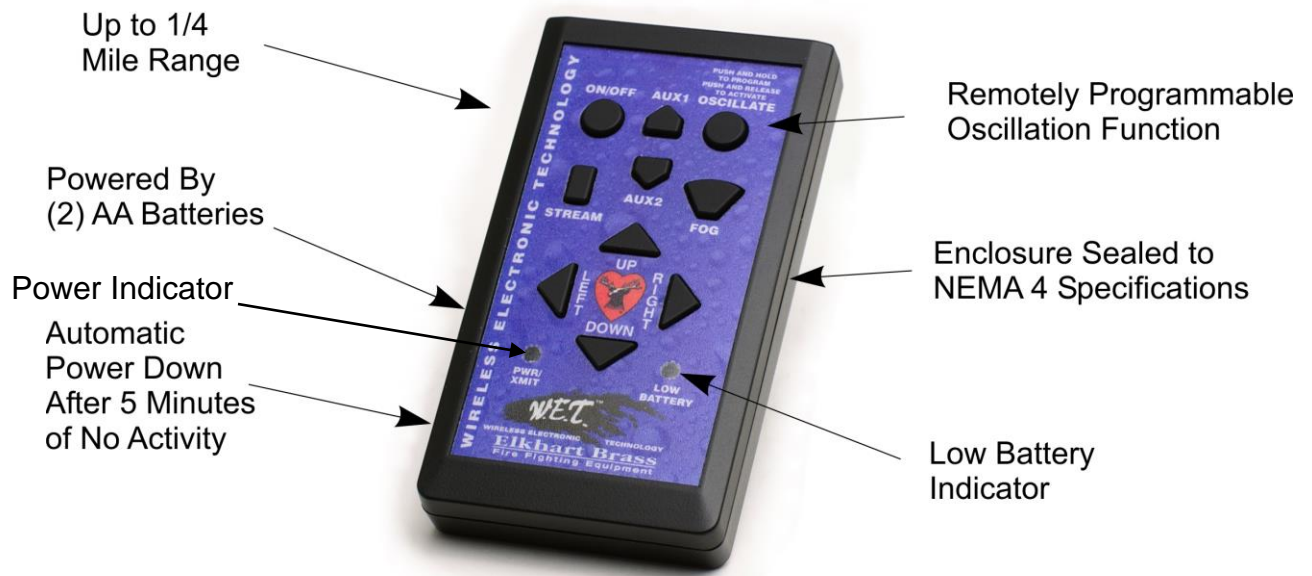

Figure 2
81282001 Handheld Transmitter Features

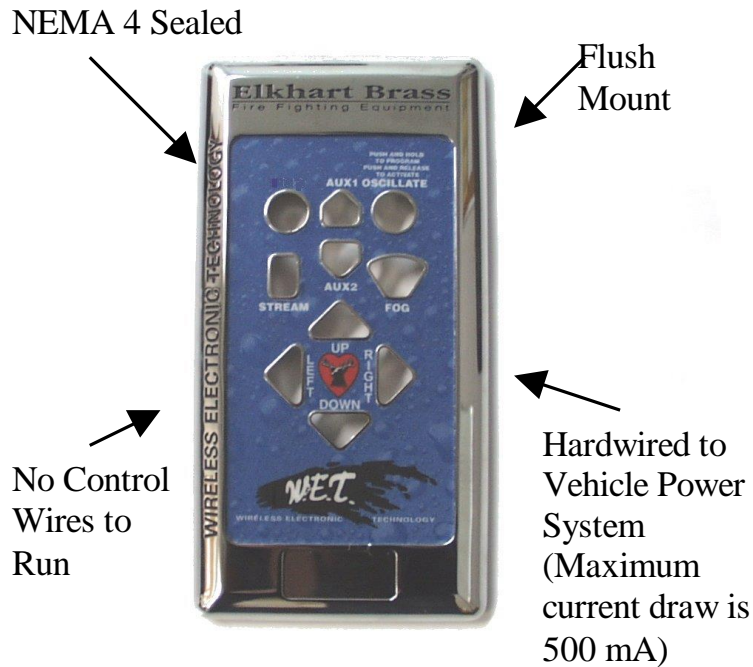

Figure 3
81327111 Panel Mount Control Features

III. SYSTEM COMPONENT DESCRIPTIONS

A. 8297 RF Upper Monitor

The 8297 Stinger RF[®] Portable Monitor is a lightweight dual-purpose monitor. The highly efficient cast aluminum waterway contains a central vane to minimize large-scale turbulence and provide superior fire streams. The patented break-apart swivel joint allows one upper assembly to be used with either of two truck mount adapters or one of the many portable bases. Nozzle stream direction is controlled by two permanent magnet type gear motors, one controlling rotation about the axis of the water inlet, and the other controlling nozzle elevation and depression. The maximum monitor flow capacity is 1250 gallons per minute with most base adapters (the clappered Siamese inlet is rated at 1000 GPM).

Stinger RF[®] monitors are normally supplied with the 282A stream shaper and the SM-1250E constant pressure (automatic) type master stream nozzle. The ST-194-A Stacked Tip combination is also available for use with the Stinger RF[®].

The following additional features are also provided in the Stinger RF[®] monitor:

ON/OFF Switch

This switch allows power from the battery to be shut off when the monitor is in portable mode.

Twist Release Handle and Lock Pin

The twist release handle makes a convenient carrying handle for both the Stinger RF[®] upper and the Stinger RF[®] with a portable base attached. It also provides for a quick conversion from the deck mode to portable base mode. The lock pin ensures that the user does not accidentally activate the twist release handle while carrying the Stinger RF[®] attached to the portable base.

Elevation Stop

The electronic elevation stop automatically limits the nozzle to a minimum elevation of 30E when in portable mode.

 **Warning:** Using the Up-Down over-ride while in portable mode can cause serious injury or death to nearby personnel. Use extreme caution when using this feature. The minimum elevation angle should be no less than 30E, and the portable base must be securely anchored using the attached strap.

Latch Pin Visual Indicator (See Figure 4)

The visual indicator is used to quickly determine when latch pins are engaged. When the latch pins are properly engaged, no part of the pins should be visible in the indicator cutout of the latch pin cap.



**Figure 4
Latch Pin**

Manual Overrides

The Stinger RF is equipped with manual override features for both the Up-Down and Left-Right functions. These overrides are intended for use in the event of power failure, or when a remote transmitter is not readily accessible.

Left-Right: To move the monitor left or right manually, push down and hold the spring-loaded knob with the right hand while grasping the return bend with the left hand. Using the left hand, either push to move the monitor to the right, or pull to reposition to the left. Please note that the left-right motor drive unit reengages only every 90E. There is no left-right locking feature while the motor drive is disengaged; keep a hand on the return bend in order to maintain stream position.

Up-Down: A hand crank mechanism is provided to allow manual control of the nozzle elevation. As a safety feature to prevent hand and finger injuries, this crank handle is always disengaged from the motor drive unit. To engage the crank handle (and simultaneously disengaged motor drive), push in on ball knob in a direction parallel to the hand-wheel shaft. While holding the ball knob in, turn crank in direction indicated on handle label to either raise or lower nozzle. When on portable base, never position nozzle at less than 30°.

Safety Switch (See Figure 5)

The Stinger RF has a safety switch feature to prevent remote operation of the unit when it is not attached to either the deck mount or portable base. This feature is designed to prevent possible serious finger injury due to entanglement in the left-right drive gearing located within the inlet area of the upper monitor assembly.



Figure 5
Safety Switch

RF Receiver/Control Module

The monitor control circuit uses a state-of-the-art PIC (Programmable Integrated Circuit) chip design. This device allows numerous control features while keeping circuit board size to a minimum. Relays within this box provide motor reversing control for the Up/Down, Left/Right and Straight Stream/Fog functions.

All functions are sent to the RF Receiver/Control Module via an encoded radio frequency link. The radio link reduces the number of wires to just the two power leads for battery charging, dramatically simplifying the installation procedure. The link allows wireless control from up to ¼ mile away.

An encoder, part of the left/right motor, provides left/right motion control feedback. The encoder allows the user to set endpoints at any combination of horizontal angles. The counter in combination with the PIC controller enables the monitor to oscillate between these endpoints.

The control system also provides secondary motor protection with the use of electronic current sensing circuitry. If the monitor encounters an obstruction before reaching a limit, this circuitry quickly senses motor stall current and automatically shuts off power

to the motor. As soon as the control switch is released, the circuit resets to allow subsequent operation of the monitor.



Caution:

Any modification of the enclosure will destroy the NEMA 4 rating and will void the warranty coverage of the Transmitter.

The following additional functions/features are provided in the RF Receiver/Control Module:

Reverse Polarity Protection: If battery connections are reversed, this feature prevents power from being applied to circuits, and prevents damage to electronic components.

Circuit Board Moisture Protection: The circuit board and circuit components are protected from moisture by an acrylic resin conformal coating. All relays have sealed covers.

Battery Enclosure (See Figure 6)

The battery enclosure contains a 5 A/H lead-acid battery, battery charging circuitry, and an LED battery charge status indicator. This indicator displays the source of power and the amount of charge on the battery. A steady LED means that truck power is connected and the battery is charging. A flashing LED signifies that truck power is disconnected. A green LED signifies 80% to a full charge of the battery. A yellow LED shows a 40%-80% charge of the battery. A red LED signifies a 20% - 40% charge. If one LED is on solid indicating a charging operation and then all three LEDs blink; this means

that the charging voltage is less than the battery voltage.



Figure 6
Battery Enclosure

Power Cable (See Figure 7)

The power cable (P/N 36846000) is a three conductor coiled self-retracting cable that provides for battery charging, and allows operation of the monitor as a deck gun while powered by the vehicles electrical system. A bayonet style connector allows convenient attachment and removal of the cable from the power receptacle located on the bottom of the RF Receiver/Control Module. The

monitor control processor senses the presence or absence of the power cable, and thus determines the appropriate allowable up-down travel range.



Figure 7
Truck Power Cable



Warning: Before removing the Stinger RF upper unit from the truck mount base, disconnect the truck power cable.

B. 8298 RF Deck Mount Adapters

The 8298 RF deck mount adapter allows use of the 8297 RF as a deck gun, and is designed for a pre-plumbed pipe directly from the apparatus pump. The 8298F RF adapter consists of the 3” 150# flat faced ANSI flange, cast waterway, swivel ring, and either a full or partial rotation gear ring. The 8298P RF adapter consists of the 3” NPT female thread, wrought waterway, swivel ring, and either a full or partial rotation gear ring.

Elkhart Brass offers a 3” companion flange kit (part no. 81315001) to be used with the 8298 RF deck mount adapter. The kit consists of an ANSI 3” 150# flange, four 5/8 – 16 bolts with nuts, and a 3” gasket.

C. Portable Bases

There are six optional portable bases with self-aligning ring gear available:

1. Two 2.5” clappered female swivel inlets
2. One 3.5” swivel inlet
3. One 4.0” swivel inlet
4. One 4.5” swivel inlet
5. One 4.0” Storz inlet
6. One 5.0” Storz inlet

The portable base support legs can be folded for compact storage in an apparatus compartment or hose bed pre-connected to a supply hose line. The folding legs are designed to be easily rotated from the stored position to the extended and locked position and back again. The spring-loaded carbide ground spikes are very hard and very sharp, important factors in the prevention of sliding under flow.

The anchor kit (Part #81460001) is used to safely secure the monitor with a steel stake and safety strap. The Stinger RF should always be anchored when it is in the portable mode. The kit also includes a Nupla[®] 4lb. Hammer with safety grip fiberglass handle, and a nylon carrying bag.

D. 8297MB-RF Storage Bracket

The 8297MB-RF is an optional, lightweight bracket that is designed to hold the Stinger RF[®] securely in place while in storage. The 8297MB-RF can be used to store the complete monitor or the portable base separate from the upper monitor. A single release lever allows for fast and efficient removal of the unit from the storage bracket. The bracket can be mounted either horizontally or vertically. (Not intended to be used while flowing water.)

E. RF Transmitters

The 8297 RF monitor uses W.E.T. (Wireless Electronic Technology), an innovative wireless radio link, to send all commands from the RF Transmitters to the RF Receiver/Control Module. This new wireless link gives the operator the ability to view the discharge stream and target from virtually any point of view from up to ¼ mile from the monitor.

81282001 Handheld RF Transmitter (Figure 8)

A sealed handheld radio remote contains all the controls necessary for operation of the monitor. The handheld remote allows the operator to direct the monitor from a significantly improved point of view. With the wireless remote, the operator can view the stream from the side and confirm that the stream is hitting its target. Separate push button switches are provided for up, down, left, right, fog, and stream functions. The handheld remotes have user selectable security codes that allow multiple transmitters and monitors to operate on the same fireground at the same time. The remote has an automatic power down feature that will shut down the power after 5 minutes of no activity. As an additional power saving feature the radio signal is only transmitted while a button is pushed. The handheld remote case has a NEMA 4 rating.



Figure 8
81282001 Handheld Transmitter

81327111 Panel Mount Primary Transmitter

(Figure 9) The fixed transmitter sends signals to the monitor via an encoded radio signal, requiring no wires between the transmitter and the monitor. It is powered by the 12V vehicle electrical system. The faceplate is intended for a flush mount onto the pump control panel. Separate sealed push button switches are provided for up, down, left, right, fog, and stream functions. It will override any handheld control, allowing the apparatus operator to retain ultimate control over the monitor. Comes with 10 foot coax antenna cable and (1) 90° antenna and (1) straight antenna.



Figure 9
81327111 Panel Mount Primary Transmitter

81353101 OEM Primary Transmitter

(Figure 10) The OEM Transmitter allows the OEM to use their own switching arrangement while still providing the benefits of W.E.T. It has all of the same features of the Primary Panel Mount Transmitter, but has a wiring harness for the installer to connect to OEM supplied switches. Comes with 10 foot coax antenna cable and (1) 90° antenna and (1) straight antenna.



Figure 10
81353101 OEM Primary Transmitter

**Caution:**

Any modification of the enclosure will destroy the NEMA 4 rating and will void the warranty coverage of the transmitter.

**Caution:**

Do not pinch wires when attaching back panel to front panel of enclosure of handheld control. Ensure all O-rings and gaskets are properly installed when closing receiver or controller enclosures.

F. AC to DC Battery Charger (P/N 52557000)

Included with your monitor is a charger that converts 100-240 VAC to 12 VDC. It can be plugged into a wall socket and connected to the monitor to charge the monitors battery. The charger comes with 4 different adapters so you can plug into most AC wall outlets. The charger has a 5 ft cord with a connector that attaches to the power connection on the upper monitor assembly.



Warning: DO NOT operate the monitor while charging the battery on a portable base. Serious damage to the charger/monitor connectors may result.

IV. CONTROL SYSTEM SPECIFICATIONS

Handheld Transmitter Specifications

- Input power 2 AA batteries (Lithium recommended)
- Output power Meets FCC part 15 requirements for license free operation
- Transmitter dimensions 6" x 3 1/4" x 1 3/8"
- Transmitter weight 10 1/2 oz.
- Operating temperature range -40°F to 150°F (-40°C to 65°C)
- FCC ID QT8PTSS2011

Transmitter Specifications

- Input power 12/24 VDC (11VDC to 30 VDC)
- Output power Meets FCC part 15 requirements for license free operation
- Transmitter dimensions 7 5/8" x 3 7/8" x 2 3/8"
- Operating temperature range -40°F to 150°F (-40°C to 65°C)
- FCC ID QT8PTSS2011

Receiver Specifications

- Power requirements 12VDC (11VDC to 14VDC) at the controller under full load
- Control current 0.07 A*
- Operating temperature range -40°F to 150°F (-40°C to 65°C)

Table 1
Motor Current Specifications

Monitor	Left/Right	Up/Down	Nozzle
Run	2.5 A	2.5 A	0.5 A
Stall	12 A	12 A	NA
Current Trip Point	9 A	9 A	4 A

Shock:

- 30 G's (55 Hz. @ .2 inch double amplitude)

Vibration:

- 15.5 G's (55 Hz. @ .05 inch double amplitude) continuous operation

Drop Test:

- The handheld transmitter must meet operating specifications after drop from 1-meter height onto concrete surface.

Environmental:

All enclosures have a NEMA 4 rating (must withstand a 1 inch stream of water (65 gpm) from a distance of ten feet for five minutes, with no water entering the enclosure

* All current ratings are at 12 volts

V. INSTALLATION INSTRUCTIONS

A. 8298F RF Deck Mount Adapter

Attach the 8298F RF flange to a 3" 150# ANSI flat faced steel companion flange on the water supply pipe (P/N #81315001). Seal the flange joint with a full-face gasket, or a suitable flange sealant. Fasten the flanges with four 5/8-11 UNC 2½" long grade 5 steel or stainless steel bolts and compatible nuts. Apply Loctite® #242 Thread Retainer to the bolt threads, then thread all nuts on hand tight, and torque them to 60-70 ft-lbs in a crisscross pattern in 20 ft-lb increments.

 **Caution:** When installing 8298F RF adapter on a companion flange it is critical that the bolts be tightened uniformly to prevent cocking of the base relative to the flange or valve. If the base becomes cocked, (see Figure 11) the 8298F RF cast flange will fracture and fail when the bolts on the "high" side are tightened. Do not mount the 8298F RF on a raised face companion flange. A flat-faced companion flange kit is available from Elkhart Brass (P/N 81315001).

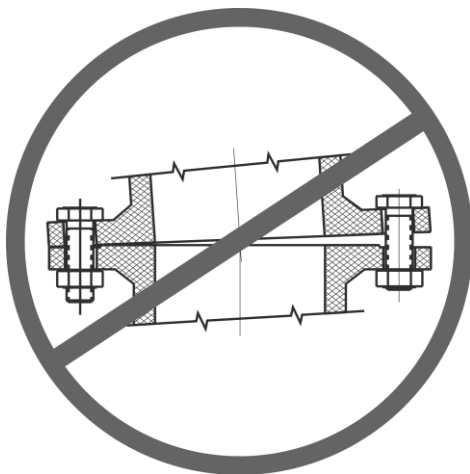

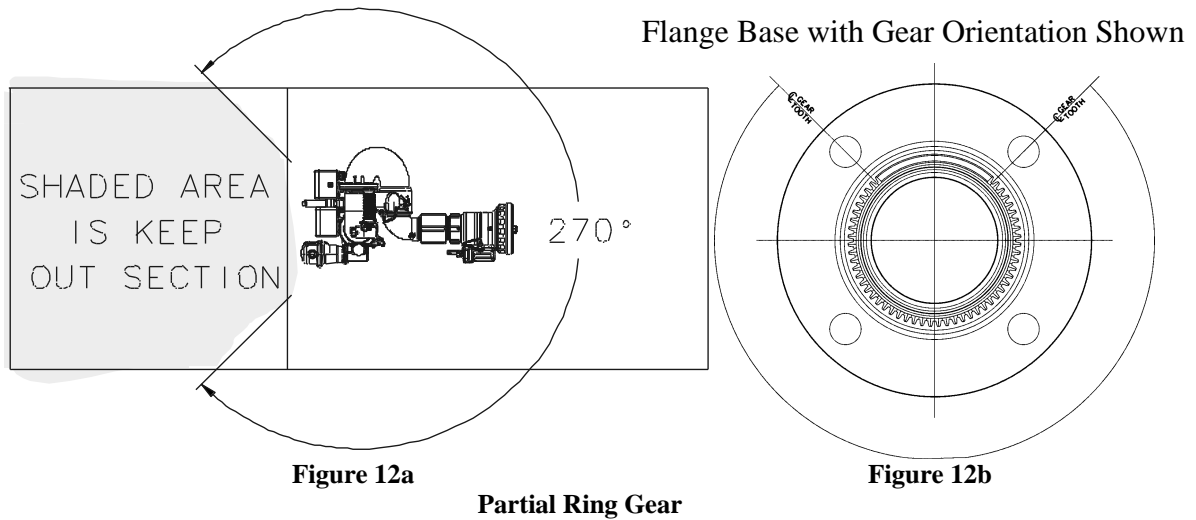

Figure 11
Improper Flange Installation

The 8298F RF deck mount comes with either a full (P/N 08298111) or partial (P/N 08298131) ring gear. The full ring gear allows the Stinger RF to move 360 degrees. The partial ring gear will allow the Stinger RF to move 270 degrees and is recommended for use with top mount pump control panel where the operator could be endangered by the stream. In order to achieve the direction of flow shown in Figure 12a, the 8298F RF with the partial gear ring will need to be positioned as shown Figure 12b before mounting.

 **Warning:** To prevent accidental aiming of the nozzle stream towards the pump operator, the 270 degrees ring gear 8298 RF deck mount (P/N 08298131) should be used on apparatus with top control panels. The ring gear teeth should be positioned as shown in Figure 12.



B. 8298P RF Deck Mount Adapter

Attach the 8298P RF to the 3" NPT male thread on the water supply pipe. Seal the joint with a suitable pipe thread sealant. Tighten the 8298P RF with a 24-inch strap wrench. Damage to any surfaces may interfere with installation of the upper monitor assembly.

The 8298P RF deck mount comes with either a full or partial ring gear. The full ring gear allows the Stinger RF to move 360 degrees. The partial ring gear will allow the Stinger RF to move 270 degrees. The 8298P RF with the partial gear ring will need to be positioned correctly before mounting (See Figure 12).

 **Warning:** The piping must be able to withstand a horizontal reaction force of at least 900 lbs at the height of the discharge elbow and from any angle of rotation that the monitor is capable of turning. Serious injury to personnel and damage to equipment can result from improper installation.

Power Cable Wiring

Place a 10A fuse between the red lead of part number 36846000 power cable and unswitched positive power lead on the vehicle. Attach the black lead from the power cable to the vehicle ground. The power source should be the output from an on-board battery charger/conditioner so that the Stinger RF battery will be maintained at full charge level while apparatus is standing in the station.

All control functions are sent to the monitor via an encoded RF signal from the transmitter; no control wiring is needed.

81327111 Panel Mount Transmitter

- a) Mark the panel cutout and mounting screw pattern per dimensions in Figure 13
- b) Cut a rectangular clearance opening and drill four $\varnothing 0.219$ " (7/32" drill) holes.
- c) Insert fixed transmitter case through panel cutout. Secure the unit to the panel with four #10-32 screws. The length of the screws should be the panel thickness plus 3/16". The screws supplied are 1/4" long. Apply Loctite #242 to the threads of the screws before tightening them.
- d) The transmitters antenna is to be mounted using the 10 foot antenna cable provided to locate one of the antennas outside the vehicle compartment in a position that provides the least obstructed line of sight to the monitor's antenna.
- e) Place a 1A fuse between the red lead of the transmitter and a switched positive power lead on the vehicle. Attach the black lead from the monitor base to the vehicle ground.
- f) All control functions are sent to the monitor via an encoded RF signal from the transmitter.

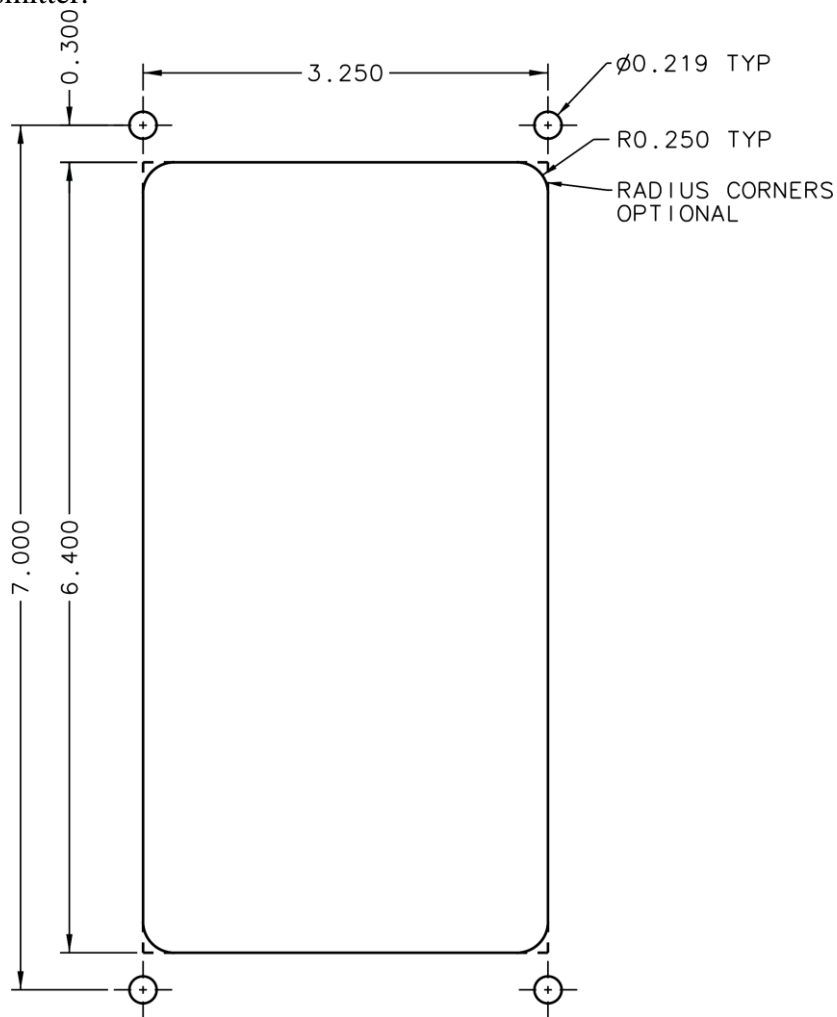

Figure 13
Panel Mount Transmitter Mounting Template

81353101 Fixed OEM Supplied Switches

- a) Place a 1A fuse between the red lead of the transmitter and a switched positive power lead on the vehicle. Attach the black lead from the monitor base to the vehicle ground.
- b) Connect all of the switch commons to the Ground (Black) connection.
- c) Connect each function to a corresponding switch. To operate the function close the function switch to ground. Any combination of pushbuttons or toggle switches can be used.
- d) Power indication can be created by attaching an LED and proper resistance between the VCC (+3 V) and Ground connections. Max rating for the VCC connection is 250 mA.
- e) The transmitters antenna is to be mounted using the 10 foot antenna cable provided to locate one of the antennas outside the vehicle compartment in a position that provides the least obstructed line of sight to the monitor's antenna.

Function	Wire Color
Ground	Black
VCC (+3 V) (Output only)	Red
Right	Brown
Down	Orange
Up	Yellow
Left	Green
Stream	Blue
Fog	Violet
Aux2	Gray
Oscillate	White
Aux1	White/Black
Stow	White/Brown

Table 2

C. Communications Address

A RF transmitter controls the 8297 RF monitor. The transmitter is digitally encoded with a security code to ensure that it does not accidentally control the wrong monitor. The receiver has a matching decoder and security code that instantaneously decodes and interprets commands. The security code is a 15-bit selectable code that is set on both the remote transmitter and the receiver.

The 8297 RF monitor is tested and shipped with a security code based upon the monitor serial number, ensuring each monitor leaves the factory with a unique code assigned to it. The security settings will normally not need to be changed. In the case of a lost transmitter or replaced control board, contact Elkhart Brass.

 Danger: Using two W.E.T. monitors with the same security code will cause the inadvertent control of the wrong monitor, resulting in possible property damage and injury to personnel. Using the factory specified codes will prevent this problem.

VI. OPERATION

A. Deck Gun Mode

1. Attachment and Operation

- (a) Install the monitor by supporting the nozzle and holding the twist handle on the upper monitor assembly. There is no need to retract the latch pins by twisting the handle. Align the inlet end of the monitor with the outlet of the truck mount base.
- (b) Lower the monitor down onto truck mount base and push down evenly so that the latch pins pass over the swivel ring. (The monitor should now be resting on top of the swivel ring.)
- (c) Confirm correct latch pin positions by checking the visual indicators in the latch pin caps (Figure 16).
- (d) Connect the truck power harness to its connector on the bottom of the upper monitor assembly.
- (e) Turn the power switch to the ON position.
- (f) Charge the monitor. Increase the pressure until the desired flow is reached.

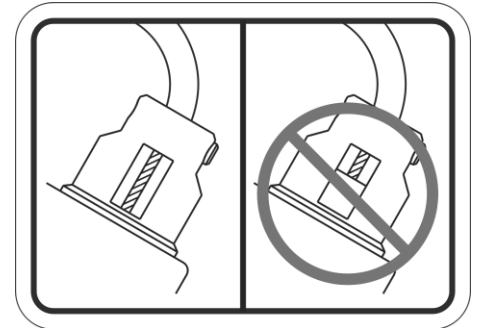

Figure 14
Latch Pin Indicators

2. Monitor Removal from the truck mount base

- a) Shut down the water flow.
- b) Disconnect the truck power harness cable by rotating connector nut approximately $\frac{1}{4}$ turn.
- c) Keep hands clear of pinch points & wait for monitor discharge to raise up & stop.
- d) Turn the power switch to the OFF position.
- e) Pull the twist release lock pin up, and hold it. Twist the handle and hold it to keep the latch pins in the released position (see Figure 15). The twist release lock pin should now be released.
- f) Support the nozzle and lift the unit straight up off the truck mount.
- g) Release the twist handle, allowing the latch pins and the twist release lock pin to return to their original position.

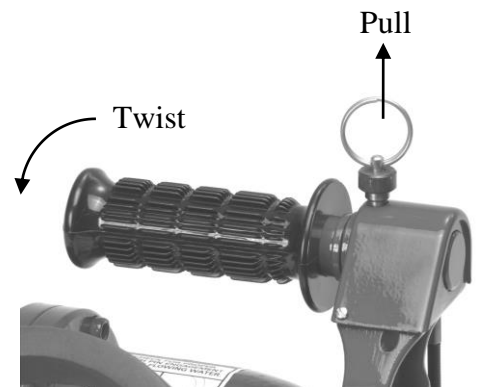

Figure 15
Twist Handle and Lock Pin

When the monitor is stored on the top mount adapter, the left-right pinion gear will be engaged with the ring gear to prevent it from spinning on the swivel joint while the

apparatus is in motion. It is recommended that only the Elkhart Model 282A stream shaper be used with this monitor. The short length of the 282-A helps to minimize stress on the discharge elbow gearing.

When the 8297 RF monitor is installed on a fire apparatus used in cold climates, a drain valve should be provided in the riser pipe that supplies the monitor. The riser should be drained immediately after each use during cold weather to prevent freezing and possible damage to the monitor and piping. The discharge portion of the monitor can be drained by simply lowering the discharge elbow below horizontal and allowing the water to drain through the nozzle.

To reduce possibility of damage to the monitor by contact with overhead doors, branches, etc, the nozzle discharge should be kept at the lowest possible angle.

B. Portable Monitor Mode

Carrying the upper monitor assembly on the truck mount adapter allows for its use as a deck gun while the portable base and hose line(s) are being deployed. Determine the portable base location (keeping in mind the need for a substantial stationary object to which the safety strap can be attached that is in line with the intended stream direction). Remember that the nozzle reaction force can be as high as 900 lbs.

1. Prepare the portable base for use by simply rotating each of the four folding legs into its locked position, starting with the two rearmost legs. It is very important that the legs be in the locked position prior to initiating water flow.
2. Anchor the portable base with the safety strap (see Figure 16). The safety strap should be attached to the portable base at the carrying handle support post on the front leg bracket and secured around a substantial stationary object. The stationary object, such as a stake, fence post, etc., should be positioned between the Stinger RF[®] monitor and the intended target. The leg bracket of the portable base should point directly at the stationary object and the intended target. The monitor should never be used with any slack in the safety strap. If no suitable object is available, the Elkhart 81460001 anchor kit must be used.
3. Attach the hose(s) to the portable base. To minimize the possibility of the charged hose lines moving the monitor, the supply hose should be kept straight in line with its respective inlet port for a distance of at least ten feet.



Figure 16
Anchored Portable Base



Warning: Before removing the Stinger RF upper unit from the truck mount base, disconnect the truck power cable.

4. Remove the upper monitor and nozzle assembly from the truck mount base (following the directions in section VI.A.2 monitor remove from truck mount base) and attach it to the portable base. Attach the upper monitor assembly to the portable base using the same technique used to attach it to the deck mount adapter (see section VI.A.1. Only use steps a, b, & c).
5. Confirm correct latch pin engagement by checking visual indicator cut outs in latch pin caps (See Figure 14).
6. Turn the power switch to the ON position.
7. Aim the monitor nozzle towards the intended target using the monitors RF transmitter. The monitor discharge should not be turned more than 45 degrees to either side of the front leg bracket.
8. Charge the hose lines slowly to prevent water hammer.
9. Operate the monitor as described in section VI.A.1, deck gun operation. (See Warning below).
10. To lower the discharge below 30 degrees, simultaneously press and hold the “down” button and the “aux 2” button on the transmitter. Once the desired position is attained, release the down button. The aux 2 button must be continually depressed in order to sustain this position. If the aux 2 button is released, the monitor will automatically return to the safe 30-degree elevation position. As soon as the nozzle elevation is raised above 30 degrees the up/down electronic stop will re-engage itself and need to be over-ridden again to go below 30 degrees elevation.



Warning:

Use extreme caution when lowering the discharge elbow below the angle allowed by the up/down electronic stop when flowing the Stinger RF® in portable mode. If the discharge is lowered below the electronic stop, the nozzle reaction force may cause the monitor and hose lines to slide. If the discharge is lowered below horizontal, the nozzle reaction force will cause the monitor and hose lines to become airborne. Serious injury or death could occur if these warnings are not followed.

C. Normal Operation

The 8297 RF Monitor uses the standard Left/Right, Up/Down, and Fog/Stream commands to provide stream direction and pattern adjustments.

To move the monitor left or right, press and hold the left or right button until the monitor discharge is in the correct position or a programmed limit is reached. To move the monitor “up” or “down,” press and hold the up or down button until the monitor is in the correct position or the electronic stop is reached. To adjust the stream pattern, press and

hold the fog or stream button until the desired stream pattern is reached. Elkhart electric nozzles have a unique ball screw drive which when it reaches the extents of travel will continue spinning until the button is released.

Any combination of left, right, up, or down can be used to achieve motion in both horizontal and vertical directions simultaneously. If the left and right buttons are pressed at the same time, the monitor will stop all motion. To resume motion, release both buttons and repress the desired direction button. This is also true for the up/down and fog/stream commands.

The handheld remote transmitter has a power saving feature that turns the transmitter power off if no signal is sent for 5 minutes. Press and hold the “ON/OFF” button until the Power LED illuminates to reactivate the transmitter. The “Low Battery” LED will flash slowly when the battery voltage drops below a predetermined level. When the low battery LED flashes rapidly, the batteries are nearly discharged and should be replaced immediately.

D. Oscillation Function

The 8297 RF monitor has an automatic left/right oscillation function, which can be used to provide continuous exposure protection or hazard mitigation with no operator input. The oscillation limits are set using the handheld or truck mount transmitters. To initiate oscillation:

1. Position the monitor at either the left or the right limit of oscillation.
2. Press and hold the oscillate button.
3. Move the monitor to the other limit of oscillation. Release the direction button
4. Release the oscillate button.
5. Press and release the oscillate button to activate the oscillation function.

The monitor will oscillate between the limits until the oscillation button is pressed again. Pressing the left or right button on one of the controls will also stop the oscillation. For safety reasons, once oscillation has stopped the oscillation limits need to be reprogrammed before it can be re-engaged. The nozzle fog, stream, and discharge elevation functions can be operated while the monitor is oscillating.

E. Manual Override

The monitor left-right and up-down motion can be controlled manually in the event of motor failure or loss of electrical power.

Up-Down

Push down on ball knob on crank handle while turning CCW to raise nozzle, or CW to lower nozzle. See Figure 17. Note that manual override crank handle is normally disengaged and will not rotate with normal control up-down motion of the nozzle. This is an important safety feature to prevent hand or finger injuries.



Figure 17
Up-Down Manual Override



Warning:

When up-down manual override is used, it is possible to position the nozzle elevation below the electronic safety limit of 30E above horizontal. Use extreme caution to prevent sliding of monitor when using manual override control.

Left-Right

The left-right manual override is controlled by a pushbutton located on top of the left-right drive gearcase on the right side of the monitor. See Figure 18. To override the motor drive mechanism, push and hold this button down while using the other hand to rotate the monitor upper portion and nozzle to the desired position.



Figure 18
Left-Right Manual Override



Caution: With the drive mechanism disengaged, there is no monitor left-right rotation lock. It may be possible for the stream position to drift due to vibration. Maintain close watch over stream position.

When motor is again actuated, the transmitter left-right drive will automatically re-engage. This may take a few seconds of motor travel.

F. Power Switch

The power switch is used to control power to the monitor. If truck power is not connected and the power switch is in the OFF position, this will remove power from all circuits inside the monitor. There will be no display indicators of any kind. If the switch is in the ON position, the monitor will operate in the portable mode as described in section VI paragraph B.



Caution: When the upper monitor assembly is on a base, and truck power is NOT connected, the monitor discharge will raise to the full up position when switch is turned on.

If truck power is connected, the monitor will operate as described in section VI paragraph C with the switch in either the ON or the OFF position. Having the switch in the ON position is recommended when the monitor is mounted on the truck.

VII. MAINTENANCE

A. Preventive Maintenance Procedures for Stinger RF Upper Assembly

Preventive Maintenance

The complete monitor and control system should be inspected during each apparatus check. Careful inspection for damage to the monitor or nozzle is especially important after use in emergency operations.

Operate each function (left-right, up-down, stream-fog, stow) with each of the transmitters.

Remove nozzle and check for debris lodged between the nozzle stem and body, or in the stream shaper inlet. Remove debris.

During nozzle flow test, inspect monitor swivel joints for leaks.

With the water off, operate the stow function, looking for any possible obstructions and check the final stow position.

Inspect all exposed wiring for signs of damage.

Note: Although a grease fitting is provided for the up-down gear case, routine greasing should not be necessary. If the monitor is exposed to a high level of radiant heat for a prolonged period, it may be possible for the factory grease to thin and run out of the gear case. In such an event, fresh grease should be applied.

After Each Use:

Check for proper latch pin operation. To do this turn the upper unit upside down and push each latch pin up into its respective hole. It should move smoothly, easily, and far enough into its hole that no part of the pin is exposed in the large bore. Using the twist release mechanism, make sure that the latch pins retract fully into their holes and are not exposed in the large bore when the grip is twisted to its limit. Release the twist grip and check to be sure the latch pins both return to the fully latched position by checking the visual indication windows in the latch pin caps (See Figure 14, Pg.15). With the twist release stop pin pulled, twist and release the grip several times. The grip should turn smoothly when released. Pull and release the twist release stop pin to make sure it is working freely. Pull the twist release stop pin and rotate the twist handle to the fully released position. Release the stop pin and then release the twist handle. The mechanism should quickly and smoothly return to the fully latched position and the twist release stop pin should reset to the locked position

The twist handle has nylon bushings, the cable guides are plastic lined, and the latch pin caps and holes are hard coated and Teflon impregnated to provide years of smooth operation without lubrication. Lubrication will attract dirt and possibly cause the latch pin mechanism to hang up, creating a severe safety hazard.



Warning:

If any part of the latch pin mechanism hangs up or does not seem to work correctly, DO NOT use the monitor. DO NOT lubricate any part of the latch pin mechanism. Contact Elkhart Brass for further instructions.

As Needed:

Check that the interior of the monitor inlet is clean. Flush out any dirt with clean water. To assure ease of left/right rotation, periodically apply a light coating of general-purpose petroleum grease to the U-Cup seal within the monitor inlet. Do not remove the seal for lubrication.

Grease the worm gear as needed with general-purpose petroleum grease. Rotate the manual override to raise the discharge to its highest elevation, apply grease to the fitting located on the lower front of the unit. Fill it until grease appears at the discharge elbow joint. Lower the discharge to the electronic stop limit and repeat the grease procedure. Lower the discharge to its lowest position, and repeat the grease procedure again. Raise the discharge until the electronic stop is reset.

Wipe off the excess grease. Clean the monitor with soap and water only. DO NOT use any type of solvent, thinner, or similar product with this unit.

Replace the labels if they become illegible, lost, painted over, or removed.

B. Maintenance Procedures for Stinger RF[®] Bases**After Each Use:**

Clean any dirt from the unit with mild soap and fresh water. DO NOT use any type of solvent, thinner, or similar product with this unit. No lubricants should be used on the portable bases. The aluminum parts are hard coated and Teflon impregnated and need no lubrication.

Inspect the ring gear, looking for damaged or dirty teeth. Clean the teeth if necessary.

Inspect the spring loaded ground spikes for damage and proper function. The spike assembly parts should move in and out freely. Inspect the ground spikes. The carbide tips should come to a sharp point. Replace the ground spike assembly if the carbide tips are damaged. Replace the ground spike assembly by removing the ground spike retainer from the leg. Turn the retainer counter-clockwise with the correct size socket or wrench, and remove the spike assembly and coil spring. Clean the leg socket. Place a small amount of Loctite #242 on the male thread of the retainer before installation. Install the spring, new spike assembly, and retainer. Tighten the retainer firmly.

Inspect each of the folding legs for correct operation of the lock pins and smooth operation on their pivot screws. Check the leg lock pins by sliding them back and forth in their bores using the yellow-capped pins on both sides of the leg near the pivot point. The lock pins should slide smoothly in the leg bore and the cone-shaped end should fit snugly into the tapered hole in the leg bracket. Retract the lock pin and rotate the leg back and forth on the pivot screw. The leg should rotate freely. If needed, flush the leg assembly with water while cycling the lock pin and/or leg through its full range of motion until smooth operation is achieved. Inspect the safety strap and snap hooks. Make sure that the spring-loaded closure on the snap hooks pivots freely and returns to the locked position.

As Needed:

Replace any damaged parts including illegible labels. Part numbers can be found in the exploded parts drawings at the end of this manual. Parts can be ordered from any Elkhart Brass distributor, or directly from Elkhart Brass Mfg. Co. Inc. Please call 1-800-346-0250 with any questions about this or any other Elkhart Brass product.

Understanding the Controller LEDs

LED Notations

- DS1 - Lights when either nozzle direction is engaged.
- DS3 – Lights when the UP or the DOWN button is depressed.
- DS4 – Lights with any left/right movement.
- DS5 – See Table 3
- DS6 – Lights when power is applied.

Table 3
DS5 Status Indicator LED (Indication VS. Meaning)

Reference	Indication	Meaning
1	Light comes on for 1 second when monitor stops	Motor has reached stall current and performing normal shutdown
2	Blinks 6 times at 1 second rate during startup	Visual indication that the μ controller is initializing – normal operation
3	Blinks 2 times at 1 second rate during startup then blinks at 1/4 second rate continuously	SW4 in wrong position – must be in position 5 for proper Stinger RF operation
4	Blinks at 1/2 second rate	Truck battery voltage <8 volts - light will blink until power is lost or is restored – early power fail (EPF) indication

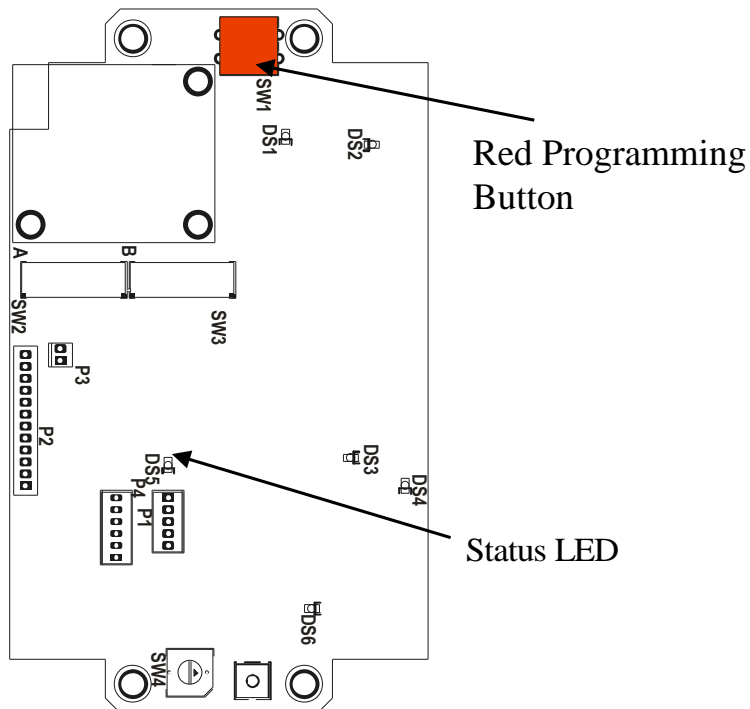

Handheld Transmitter

Battery Type

The 8297 RF handheld transmitter uses two AA lithium batteries. The low battery light will illuminate with approximately two hours of transmission time remaining before the batteries are completely discharged. Due to the time-voltage characteristics of rechargeable batteries, this time could be drastically reduced if rechargeable batteries are used.

Replacing the Battery

The batteries can be replaced with any standard fresh AA lithium batteries.

Turn the transmitter power off.

Remove two screws and the battery cover.

Remove the old AA batteries.

Insert the new AA lithium batteries.

Replace the battery cover using the screws.

VIII. MONITOR & STREAM SHAPER HYDRAULIC DATA

Interpreting Flow Data

The following graphs offer the pressure losses for the monitor (and other devices) in terms of Total Static Pressure Drop. This Total Static Pressure Drop can be found by measuring the difference between the static inlet pressure and the static outlet pressure. The static pressure at either of these points can be found using a simple pressure gauge. An illustration of this method can be seen below.

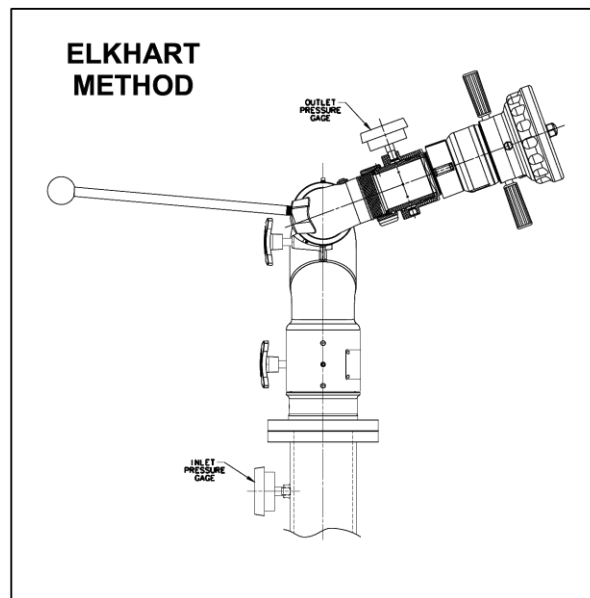

In mathematical terms, the Total Static Pressure Drop is the change in Velocity Pressure plus Friction Loss. The change in Velocity Pressure results from the change in velocity

of water caused by the change in the cross section of a waterway. Friction Loss results from the drag and sidewall interference of the water through a device. A simple equation can be seen below.

$$\Delta P_S = H_F + \Delta P_V$$

ΔP_S = Total Static Pressure Drop
 H_F = Friction Loss
 ΔP_V = Velocity Pressure Loss

In the firefighting industry, the terms Total Static Pressure Drop and Friction Loss tend to be used interchangeably. However, these are significantly different measurements. This misconception could ultimately lead to lower than anticipated performance from equipment. **When designing a system and determining performance, Total Static Pressure Drop is the value that should always be used.** The Friction Loss curve is also supplied in order to make a comparison with competitor products that may only supply Friction Loss curves. If there are any further questions regarding this matter, please contact Elkhart Brass.

8297 Stinger Deck Mount Losses
3.0" Inlet and 2.5" Outlet

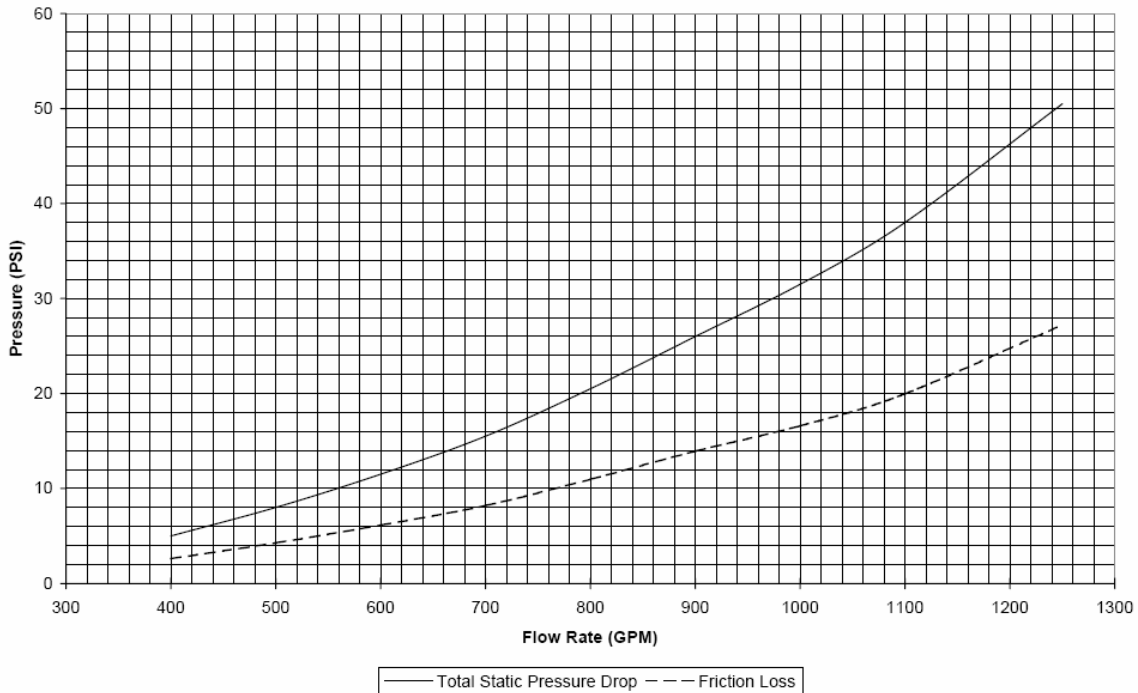

**8297 Stinger Portable Base or Two Inlet Losses
2 x 2.5" Inlets and 2.5" Outlet**

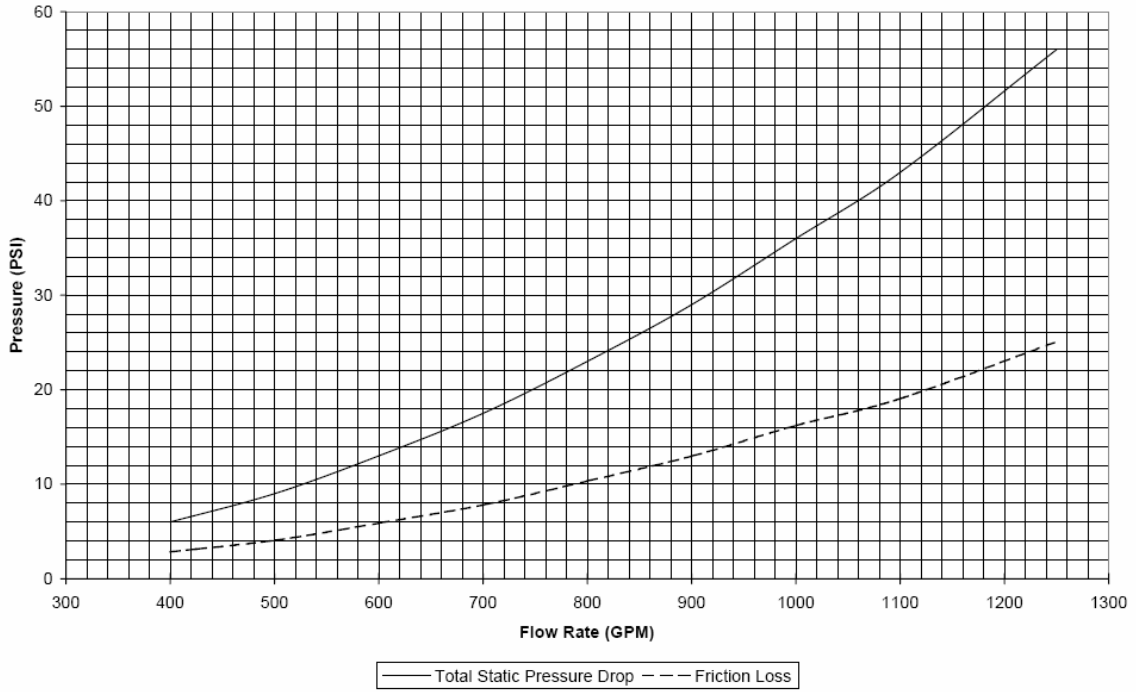

282-A, 282-B Stream Shaper Losses

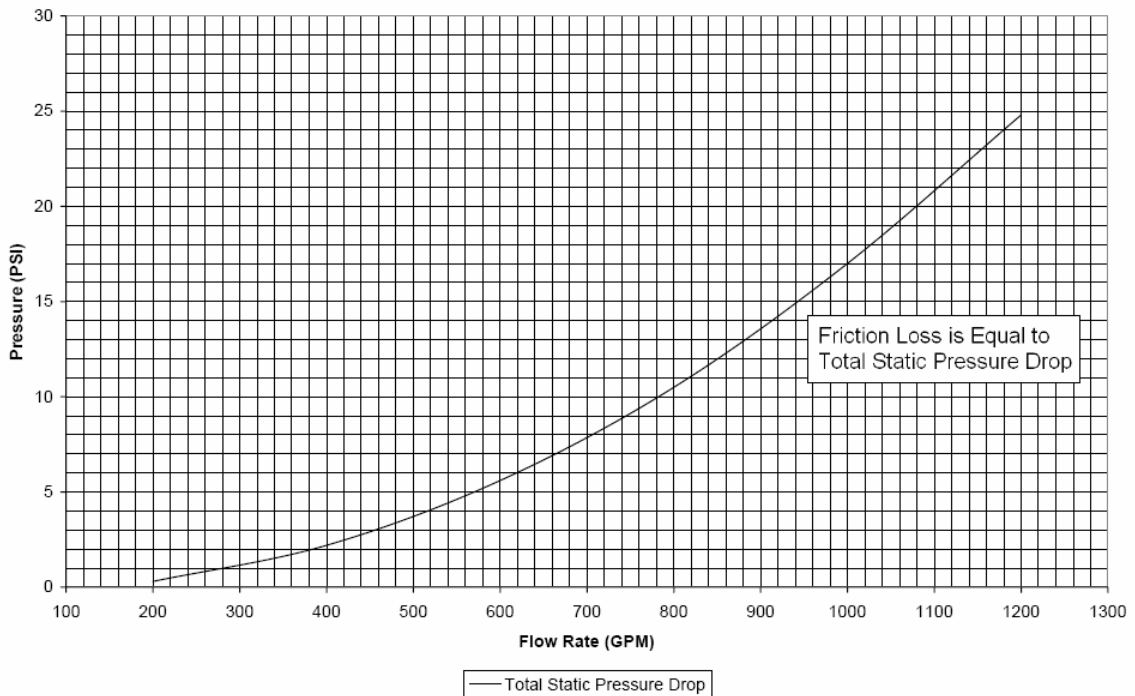



ELKHART BRASS MFG. CO., INC.

P.O. Box 1127 · 1302 West Beardsley Ave.

Elkhart, Indiana 46515

E-mail: info@elkhartbrass.com

Website: www.elkhartbrass.com

(800) 346-0250