

EXTENDER



Table of Contents

I. Product Safety.....	1
II. System Features.....	2
III. System Component Descriptions.....	4
A. 8598 Extender.....	4
B. Controller.....	4
IV. Control System Specifications.....	4
V. Mounting Structure Requirements.....	5
VI. Installation Instructions.....	10
A. Extender.....	10
B. Controller.....	12
C. Wiring.....	13
VII. Operating Instructions.....	14
VIII. Maintenance and Inspection.....	15
A. Extender.....	15
B. Controller Understanding the controller LED's.....	15
IX. Hydraulic Data.....	16

I. Product Safety



Important:

Before installing and operating this equipment, read and study this manual thoroughly. Proper installation is essential to safe operation. In addition, the following points should be adhered to in order to ensure the safety of equipment and personnel:

- 1 All personnel who may be expected to use this equipment must be thoroughly trained in its safe and proper use.
- 2 Never exceed a moment of 9,480 in lbs at the outlet connection (see section V. Mounting Structure Requirements).
- 3 Become thoroughly familiar with the hydraulic characteristics of this equipment and the pumping system used to supply it. To produce effective fire streams, operating personnel must be properly trained.
- 4 Whenever possible, this equipment should be operated from a remote location. Do not needlessly expose personnel to dangerous fire conditions.
- 5 Open water valve supplying this equipment slowly, so that the piping fills slowly, thus preventing possible water hammer occurrence.
- 6 After each use, and on a scheduled basis, inspect equipment per instructions (see section VIII. Maintenance and Inspection)
- 7 Any modification to the controller's enclosure will destroy the NEMA 4 rating and void warranty coverage of the enclosure and all components within.

II. System Features

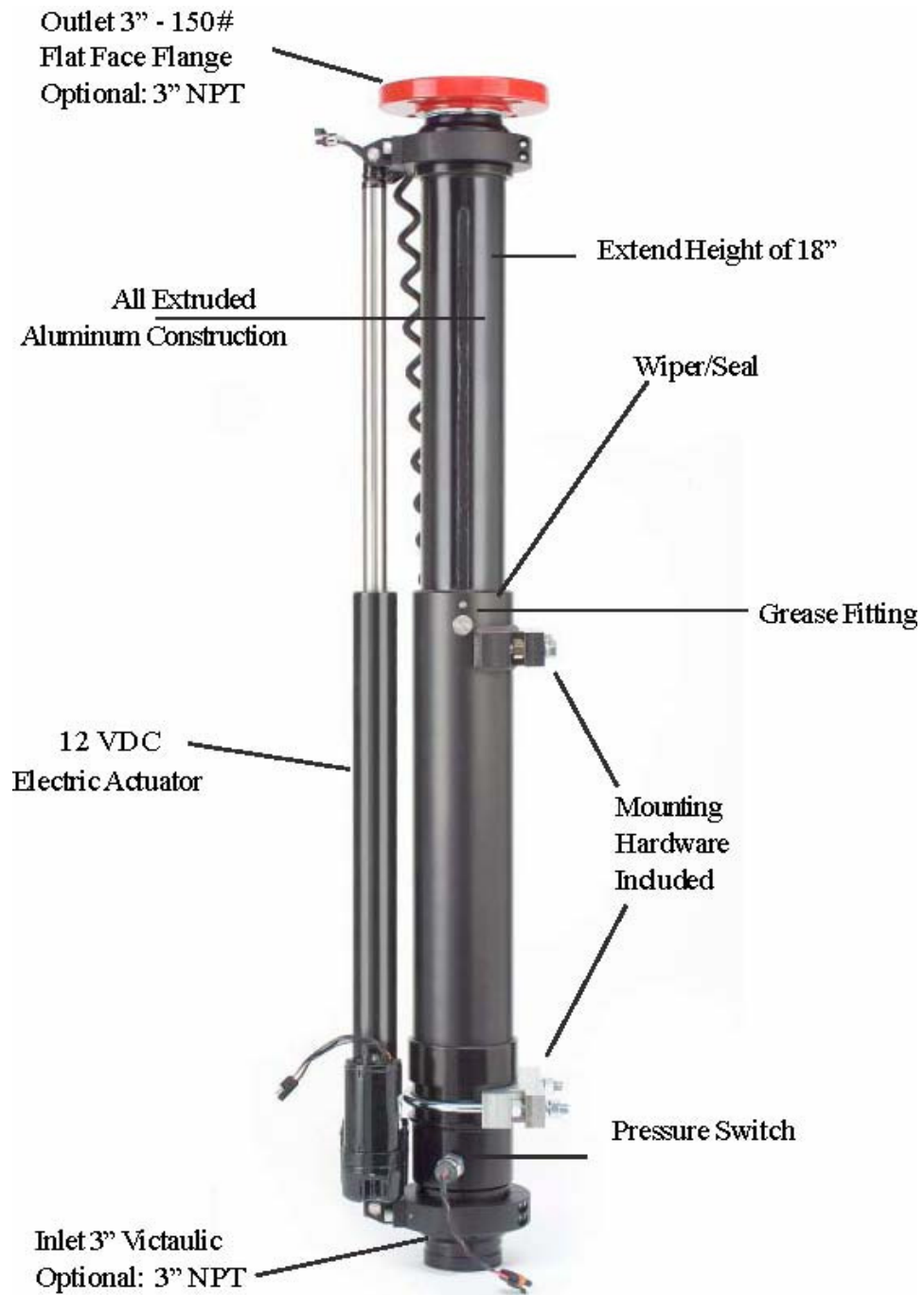

Figure 1

EXTENDER

8598 Features

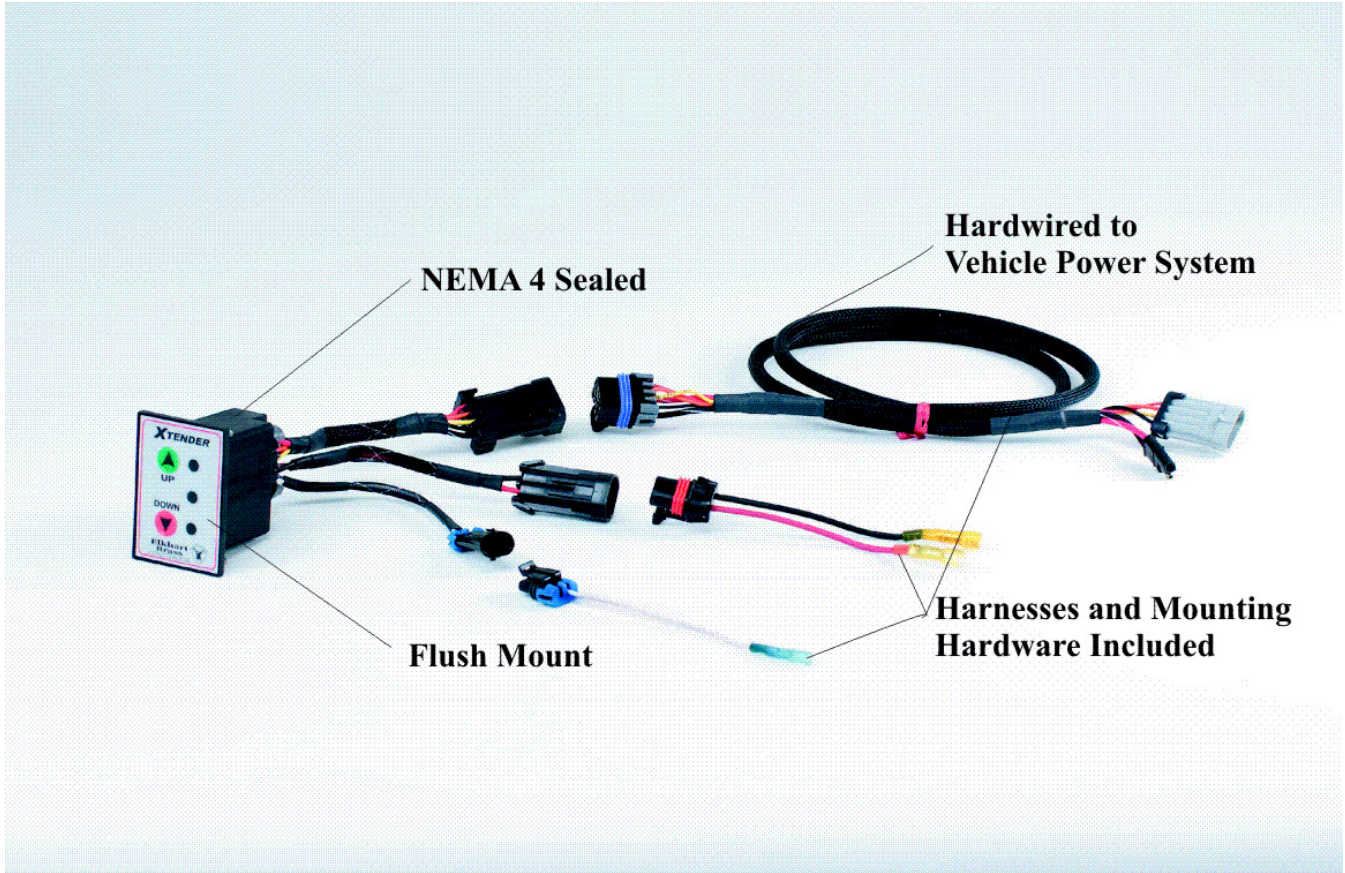

Figure 2
Extender Front Panel Controller Features

III. System Component Descriptions

A. 8598 Extender

The Extender is an electric operated telescoping waterway. It is designed to elevate a deck monitor 18 inches so the stream path can clear obstructions like truck cab, lights, hose bed, etc. It is designed to be used in full up position, but can be used in the full down position. The water supply connection is 3 inch Victaulic (optional 3 inch NPT male thread). The discharge connection is 3 inch 150 lb. ANSI pattern flange (optional 3 inch NPT male threads).

The maximum flow capacity is 1250 gallons per minute. The maximum inlet pressure is 200 psi. A pressure switch prevents the Extender from moving when internal pressure exceeds 10 psi to prevent damage to equipment or injury to personnel caused by unexpected changes in stream elevation.

B. Controller

The Extender's control circuit uses a state-of-the-art control logic to keep the controller size to a minimum. The controller utilizes modern switch styles to control the deck gun elevator. A momentary push elevates or lowers the unit. The unit does not stop in mid position. An optional in-cab warning lamp (supplied by the OEM) shows if the Extender is not fully retracted.

IV. Control System Specifications

Truck Voltage

Minimum 11 VDC to Maximum 15 VDC

Recommended Ratings

Operating voltage - 13.8 VDC

Primary fuse rating - 10A

Position warning output fuse rating - 125mA

Extender

Maximum flow capacity is 1250 gpm

Maximum inlet pressure rating is 200 psi

Maximum moment is 9,480 in/lbs at the outlet connection

Moment = $RF \times H$

Where RF = Reaction Force (Pounds)

H=Height of vertical discharge pivot (Inches) (See **Figure 3**)

V. Mounting Structure Requirements

The mounting structure must be able to safely withstand the forces shown in **Figure 3**. For monitor and nozzle combinations other than Elkhart 8500 RF and SM-1250E consult Elkhart Brass engineering department or calculate moment at monitor inlet. Moment must not exceed 9480 in/lb or 790 ft/lb. (See nozzle reaction formulas on page 6.)

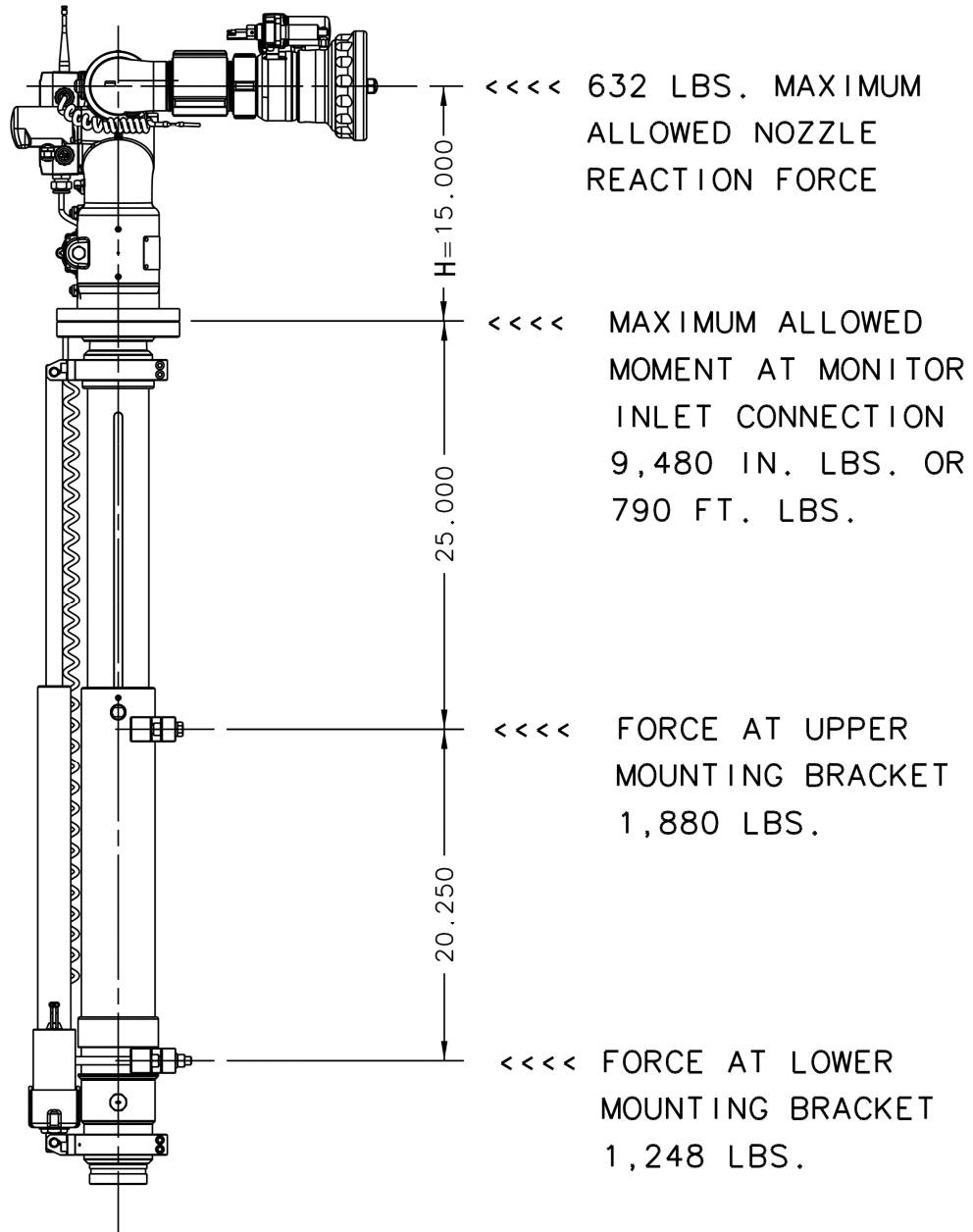

Figure 3
Forces

Nozzle Reaction Formula

STRAIGHT BORE NOZZLES

$$NR = 1.5 d^2 NP$$

Where NR = Nozzle Reaction (Pounds)

d=Nozzle Diameter (Inches)

NP = Nozzle Pressure (psi)

1.5 is a constant

COMBINATION FOG NOZZLES

$$NR = 0.0505 QP$$

Where NR = Nozzle Reaction (Pounds) Q = Flow (GPM) P =
Nozzle Pressure (psi at base of nozzle) 0.0505 is a constant

This formula is with nozzle set on straight stream. Reaction will decrease as
pattern is widened to fog.

NOTES:

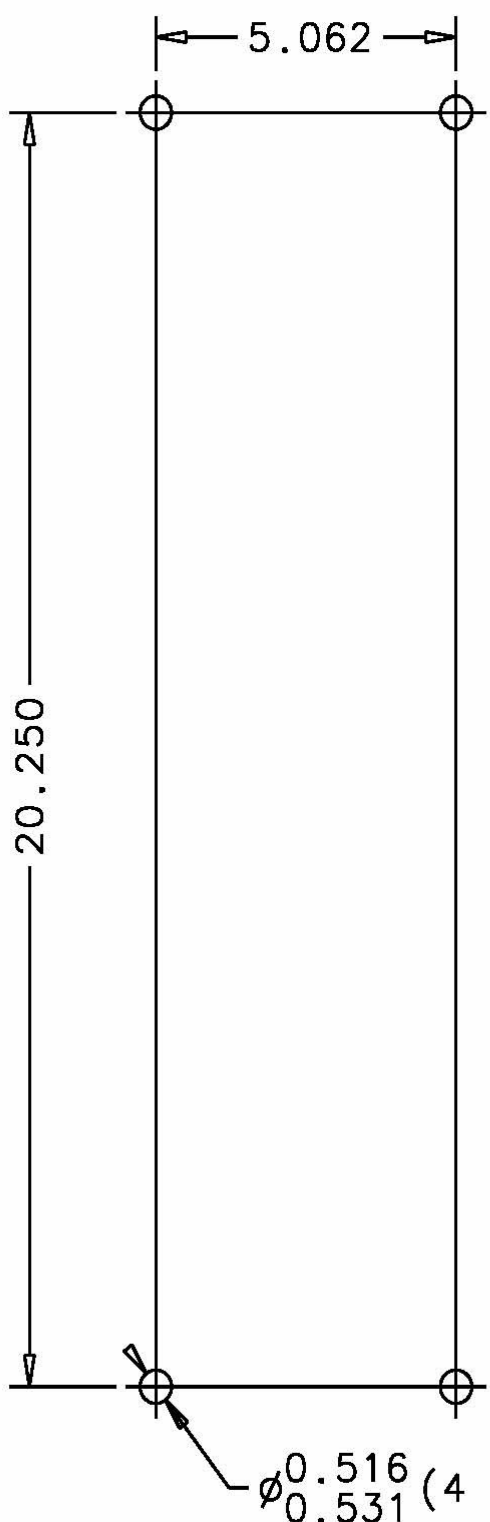

MOUNTING HOLE
PATTERN FOR
8598 EXTENDER

(FIGURE 4)

$\phi 0.516$
 0.531 (4 HOLES REQUIRED)

MOUNTING
SURFACE
VIEW

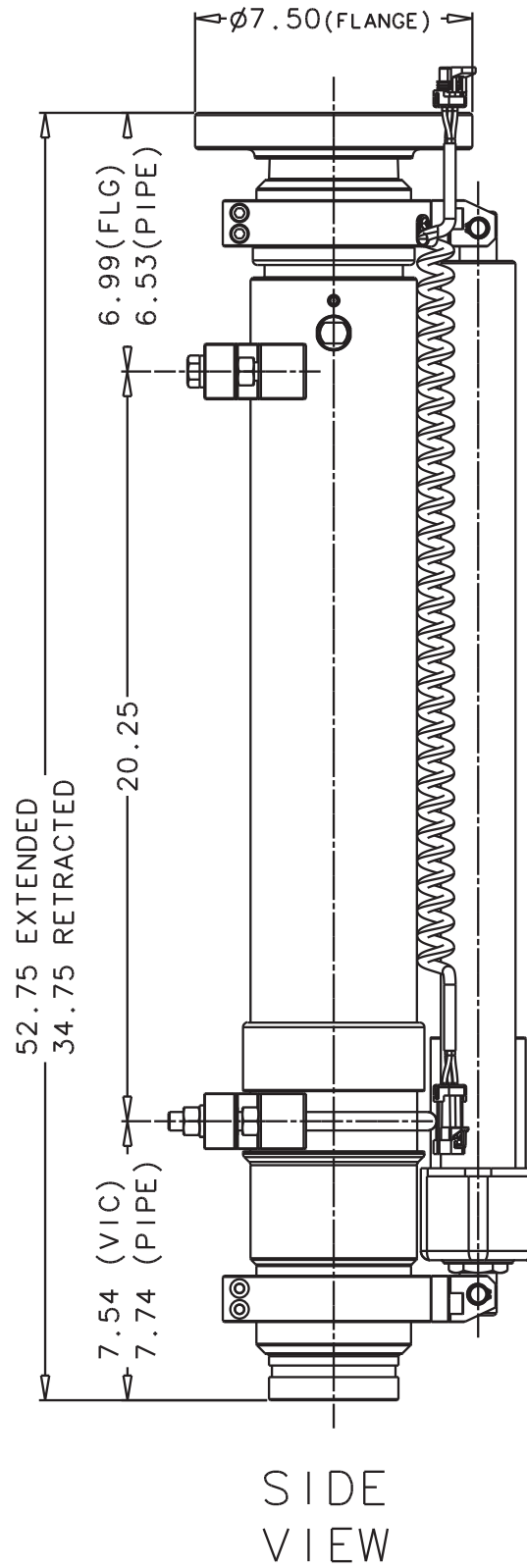
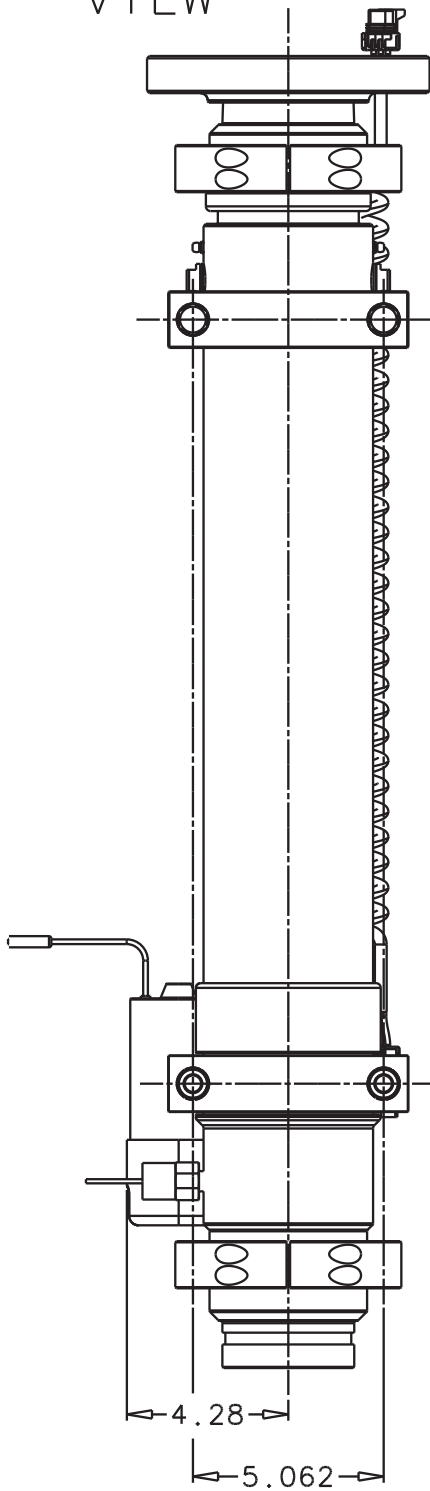

SIDE
VIEW

Side View Unit Dimensions

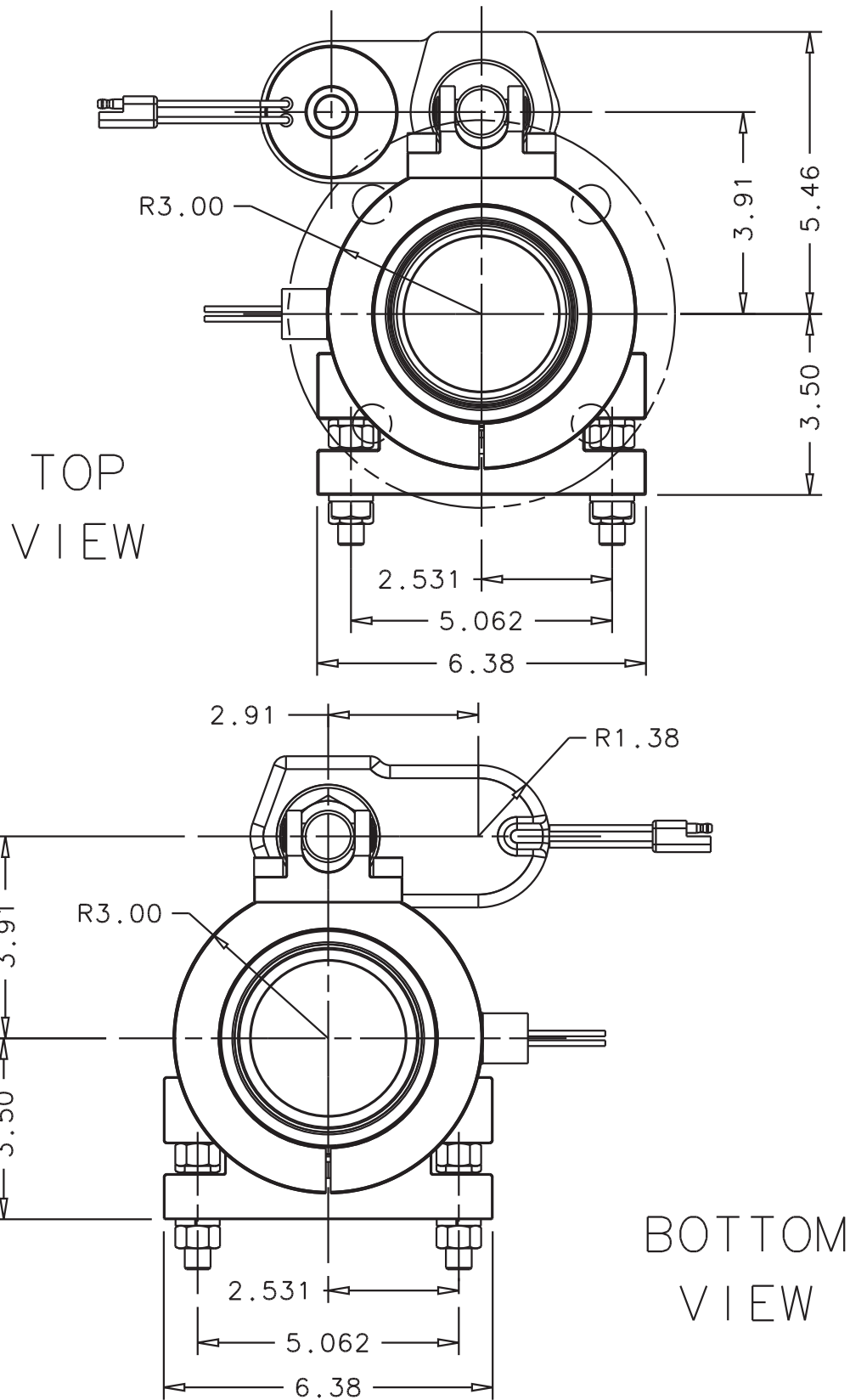

Top and Bottom View Unit Dimensions

VI. Installation Instructions



Warning: Mounting System not intended to support plumbing or absorb stress from plumbing. See Figure 3.

A. Extender

1 Remove nuts (#2) and lock washers from lower mounting clamp/bracket. Loosen nuts (#1) just enough to allow clamp/bracket to rotate on unit (for shipment, nuts (#1) were tightened against surface “A” of the clamp body to hold the clamp in place.) **See Figure 5.**

2 Remove bolts, lock washers, thrust washers, and nuts from the upper mounting bracket. **See Figure 6.**

Position unit onto the support structure (recommended clearance hole size for upper bolts and lower u-bolt is 0.516-0.531 diameter) making sure the “C” surface of both the upper mounting clamp and the lower bracket/clamp fully contact the support structure. **See Figure 4.** Make sure that the clamp at the end is positioned in the retention groove of the inlet adapter. Reinstall upper mounting bracket bolts and lower mounting bracket nuts (#2) only enough to compress the lock washers about half way.

3 On the lower mounting bracket/clamp, position (#1) nuts loosely against surface “A” of the mounting bracket/clamp. In small even increments, tighten (#2) nuts to 33-35 ft/lbs. Check to see that the (#1) nuts remained loose, if either of them are tight against surface “B” loosen them and recheck the torque on (#2) nuts.

4 Tighten lower mounting bracket (#1) nuts against surface “B” to 65-75 ft/lbs in 10 lb increments. There is a thrust washer on the surface “B” side of (#1) nuts.

5 Tighten upper mounting bracket bolts and nuts to 65-75 ft/lbs in 10 lb increments.

6 Connect upper plug on power extension harness to plug on Elkhart monitor (if monitor is an EXM, use adapter harness P/N 37325000 provided). Secure bottom end of power extension harness as required. Connect monitor power harness 36820000 supplied to bottom connection of power extension harness. See monitor wiring section of Elkhart monitor instructions for connection instructions & fusing requirements. (If installing an EXM monitor, all controls must be RF so only power & ground will be required at this connection)

7 Minimize stress to mounting system by connecting inlet to water supply with flexible hose.

FIGURE 5

LOWER MOUNTING BRACKET
(VIEW FROM BELOW)

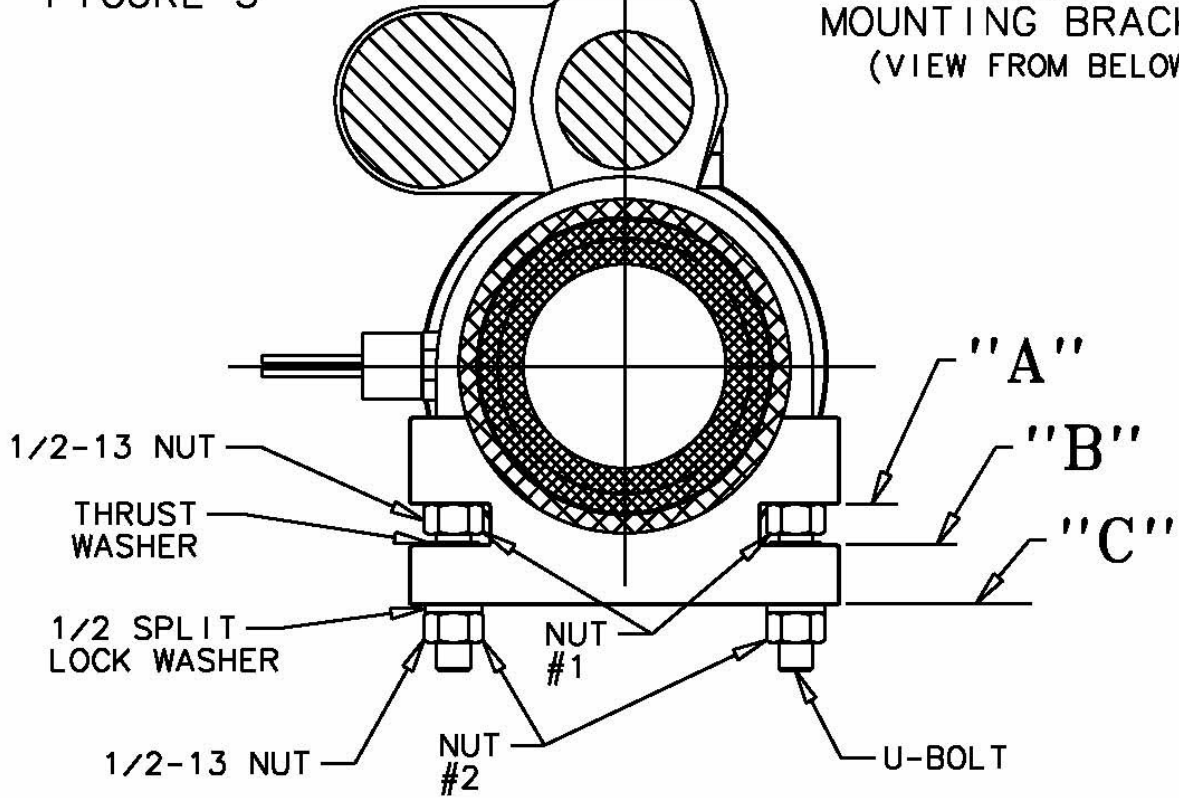
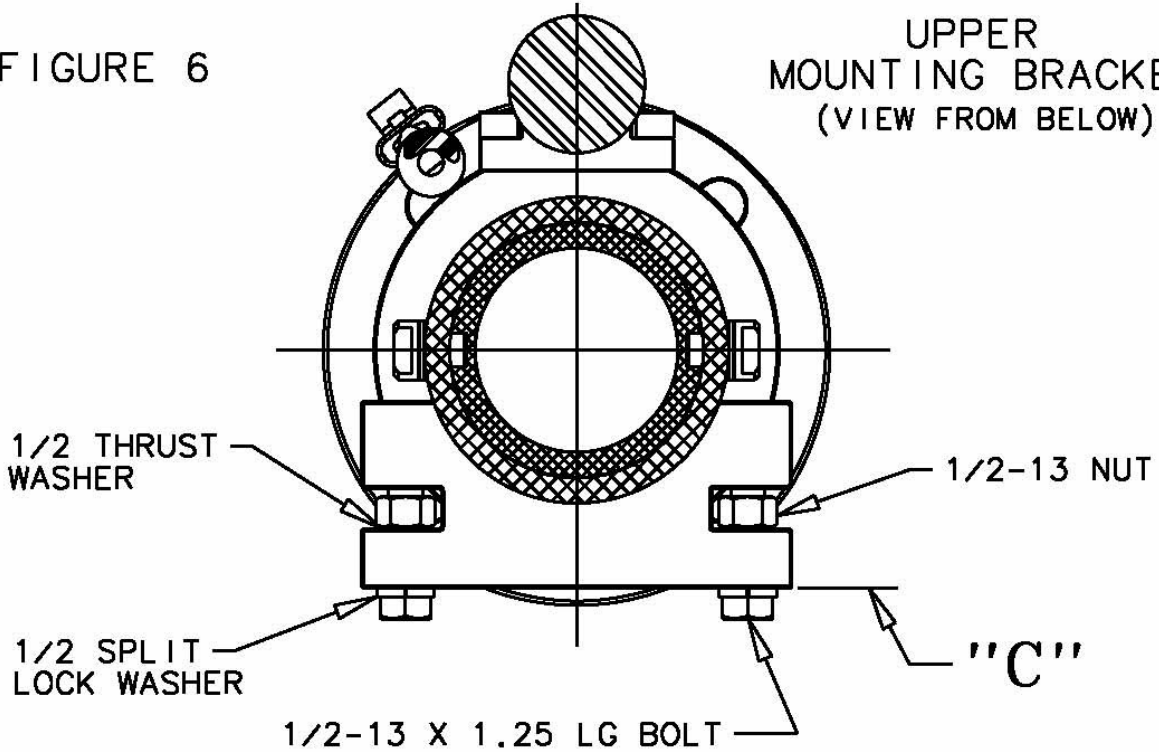

FIGURE 6

UPPER MOUNTING BRACKET
(VIEW FROM BELOW)



B. Controller

- 1 Mark the panel cutout and mounting screw pattern per dimensions in Figure 7.
- 2 Cut a rectangular clearance opening and drill four 0.156 (5/32" drill) holes.
- 3 Insert fixed control case through panel cutout. Secure the unit to the panel with the supplied four nuts and lock washers. Do not over tighten.

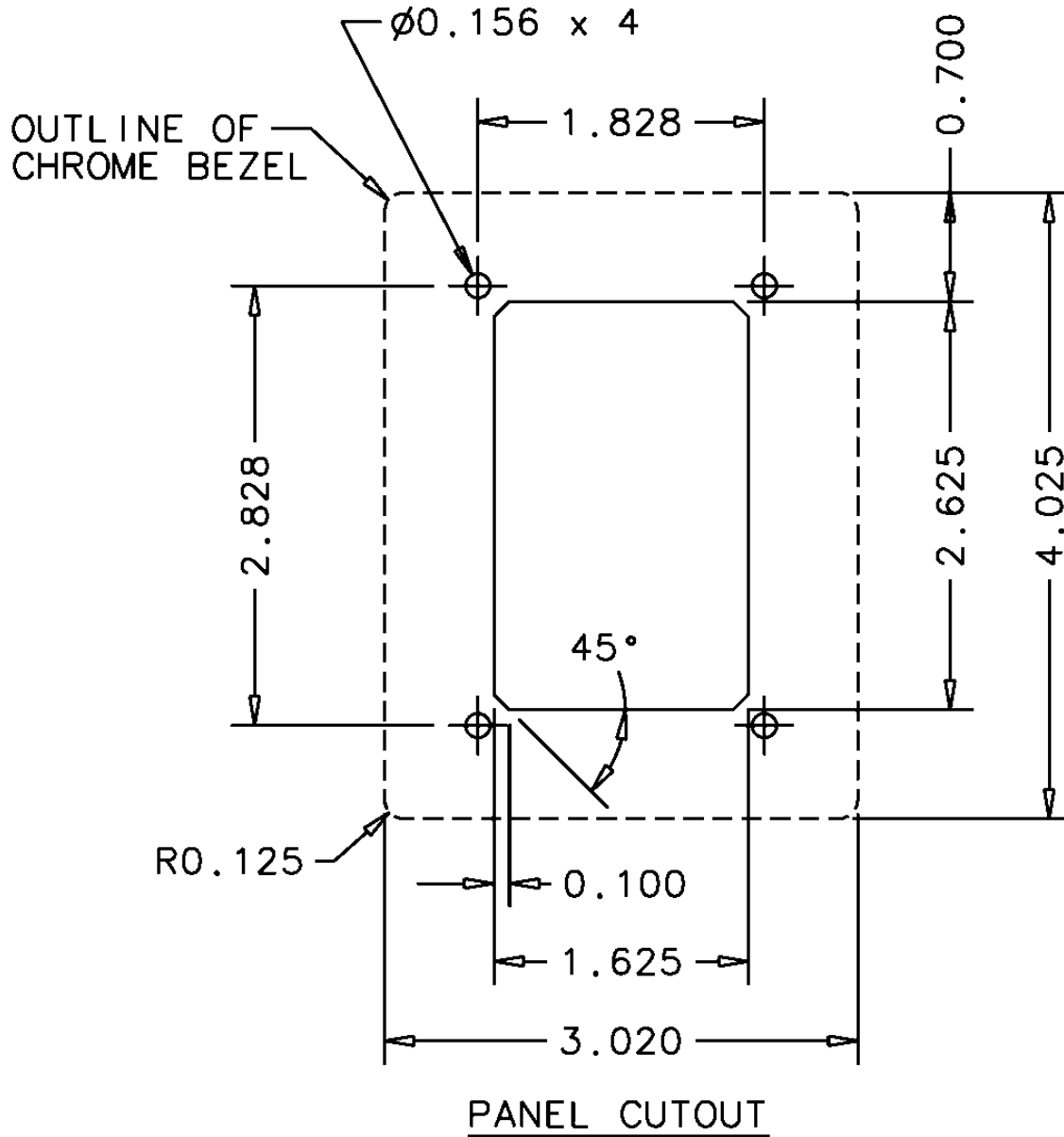
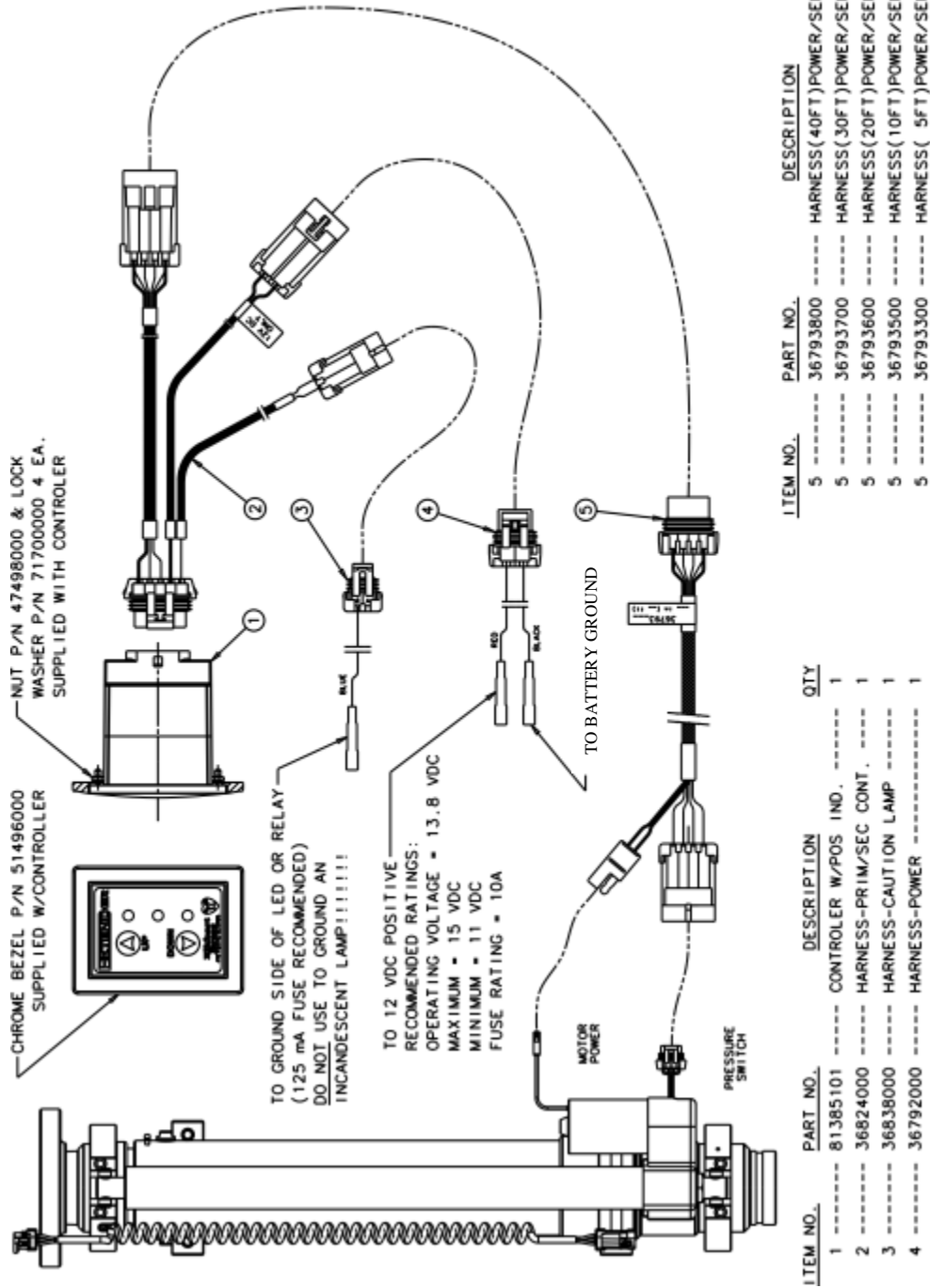

Figure 7
Extender Panel Mount Instructions

C. Wiring

(See Figure 8 for connections).



Caution: Route wires away from sharp objects and heat sources. Support with ties as needed to reduce stress on connectors and/or motor and sensor leads. When an EXM monitor is mounted on the 8598, the CAN wire length due to the monitor & extender coiled cables exceed 3 FT that it needs to be considered the CAN component at one end of the main CAN line and therefore must be set for termination.

VII. Operating Instructions

NOTE: The Extender cannot be operated with water pressure above 10 PSI.

The Extender is the perfect accessory for monitors used on pumpers where the monitor needs to clear an obstruction. The Extender is a continuous motion elevator that once engaged will travel the full distance (18") either up or down, without user intervention.

A. Press the "UP" button on the controller when the Extender is in the fully retracted (down) position.

1. The unit will fully extend without the operator having to hold the button down.
2. Once the unit starts moving the yellow LED will illuminate and the green LED will blink at a moderate rate.
3. Once the elevator is fully extended the yellow LED will extinguish and the green LED will remain on indicating a fully extended (up) condition.
4. If, during upward travel, the operator pushes the "DOWN" button, the Extender will immediately stop, pause for approximately one second, and start back down.
 - a. The yellow LED will remain on.
 - b. The green LED will extinguish and the red LED will start blinking once the unit starts moving.
 - c. At the end of downward travel, the yellow LED will extinguish and the red LED will remain on indicating a fully retracted (down) position.

B. Press the "DOWN" button on the controller when the Extender is in the fully extended (up) position.

1. The unit will fully retract.
2. Once the unit starts moving, the yellow LED will illuminate and the red LED will blink at a moderate rate.
3. Once the Extender is fully retracted, (down) the yellow LED will extinguish and the red LED will remain on indicating a fully retracted (down) condition.
4. If, during downward travel, the operator pushes the "UP" button, the Extender will immediately stop, pause for approximately one second, and start back up.
 - a. The yellow LED will remain on.
 - b. The red LED will extinguish and the green LED will start blinking once the unit starts moving.
 - c. At the end of travel, the yellow LED will extinguish and the green LED will remain on indicating the unit is in the fully extended (up) position.

Whenever the Extender is NOT fully retracted (down), a ground is switched on so that an optional position warning indicator, provided by the OEM, will come on. The ground is capable of sinking 200mA of current, which is sufficient to drive an LED or relay coil. The ground is only available when the unit is NOT in the fully retracted position, in the fully retracted (down) position the ground is switched off.

If either button, (“UP” or “DOWN”), on the controller is pushed while the waterway is pressurized all three LED’s will blink on and off at a very rapid rate. They will continue to blink until the waterway pressure is less than 8 PSI and the operator pushes either the “UP” or “DOWN” button. If the elevator is moving when the waterway becomes pressurized then the Extender will immediately stop and all three LED’s will blink on and off at a very rapid rate. The Extender will not move until the pressure is less than 8 PSI and the operator resets the system by pressing either the “UP” or “DOWN” button. Pushing the “UP” or “DOWN” button will stop the flashing LED’s reset the LED’s back to their normal mode of operation and start the unit traveling in the chosen direction.

NOTE: Once the pressure has been released and the unit has been reset, all functions will return to their normal mode of operation.

VIII. Maintenance and Inspection

A. Extender

The complete Extender system should be inspected during each apparatus check. Careful inspection for damage to the Extender is especially important after use in emergency operations.

1. Operate each function (Up-Down) with the controller.
2. Inspect all exposed wiring for signs of damage.
3. Inspect nuts and bolts for signs of damage.
4. Grease as needed to maintain a thin film of grease on the extension tube. Grease with unit down. Wipe off excess grease and grit that accumulates at the top of the outer tube and wiper.

B. Controller

Understanding the controller LED’s

1. Red LED on - Extender is all the way down.
2. Green LED on - Extender is all the way up.
3. Red LED flashing and yellow LED on - Extender is traveling down.
4. Green LED flashing and yellow LED on - Extender is traveling up.
5. Green, Yellow, and Red LED flashing - An error condition exists. Unit is pressurized and one of the travel buttons was pressed or the unit was traveling and the waterway became pressurized.

IX. Hydraulic Data

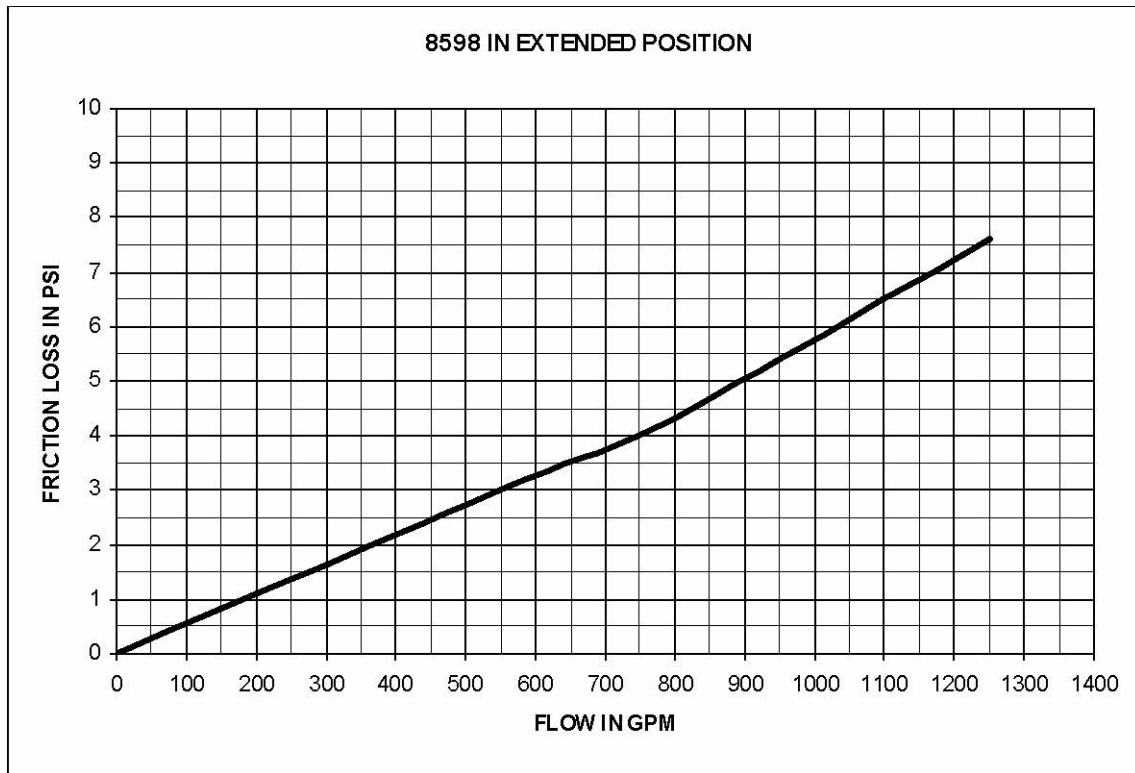

Notes:



CORPORATE OFFICES:

ELKHART BRASS MANUFACTURING CO., INC.
1302 W. BEARDSLEY AVENUE ELKHART, IN 46514
TEL. (574) 295-8330
TOLL FREE (800) 346-0250
FAX (574) 293-9914
EMAIL: INFO@ELKHARTBRASS.COM

WWW.ELKHARTBRASS.COM