

Installation, Operating, & Maintenance Instructions



8494 Sidewinder™ **Monitor**

98275000 REV. D

1-574-295-8330
www.elkhartbrass.com

ELKHART BRASS
FIRE FIGHTING EQUIPMENT A SAFE FLEET BRAND

TABLE OF CONTENTS

I.	PRODUCT SAFETY.....	5
II.	SYSTEM COMPONENT DESCRIPTIONS	7
A.	<i>Sidewinder</i> [™] Monitor	7
B.	81713000 Control Module.....	7
C.	81122001 Standard Control Box	8
D.	81172001 Joystick Control Box (Optional).....	8
E.	5000 Series Nozzles.....	8
F.	81181001 Water Valve Kit (Optional)	9
G.	SM-10FE De/Anti-Icing Nozzle.....	9
III.	CONTROL SYSTEM SPECIFICATIONS	10
A.	Monitor Controller Specifications	10
B.	Optional Valve Controller Specifications.....	10
IV.	INSTALLATION INSTRUCTIONS.....	11
A.	Component Mounting.....	11
1.	<i>Sidewinder</i> [™] Monitor.....	11
2.	81713000 Control Module.....	12
3.	81122001 Control Box & 81172001 Joystick Control Box (Optional).....	12
4.	81181001 Water Valve Kit (Optional)	14
V.	OPERATING INSTRUCTIONS	16
A.	Normal Operation	16
1.	81122001 Standard Control Box	16
2.	81172001 Joystick Control Box	16
B.	Manual Override	16
VI.	MAINTENANCE	17
A.	Preventive Maintenance.....	17
VIII.	PARTS DRAWINGS.....	184

I. PRODUCT SAFETY



Important:

Before installing and operating this equipment, read & study this manual thoroughly. Proper installation is essential to safe operation. In addition, the following points should be adhered to in order to ensure the safety of equipment and personnel:

1. All personnel who may be expected to use this equipment must be thoroughly trained in its safe and proper use.
2. Before flowing water from this device, check that all personnel (fire service and civilian) are out of the stream path. Also, check to make sure stream direction will not cause avoidable property damage.
3. Become thoroughly familiar with the hydraulic characteristics of this equipment, and the pumping system used to supply it. To produce effective fire streams, operating personnel must be properly trained.
4. Whenever possible, this equipment should be operated from a remote location. Do not needlessly expose personnel to dangerous fire conditions.
5. Open water valve supplying this equipment slowly, so that the piping fills slowly, thus preventing possible water hammer occurrence.
6. After each use, and on a scheduled basis, inspect equipment per instructions in section VI.
7. Any modifications to the electrical enclosures will destroy the NEMA 4 rating and void warranty coverage of the enclosure and all components within.

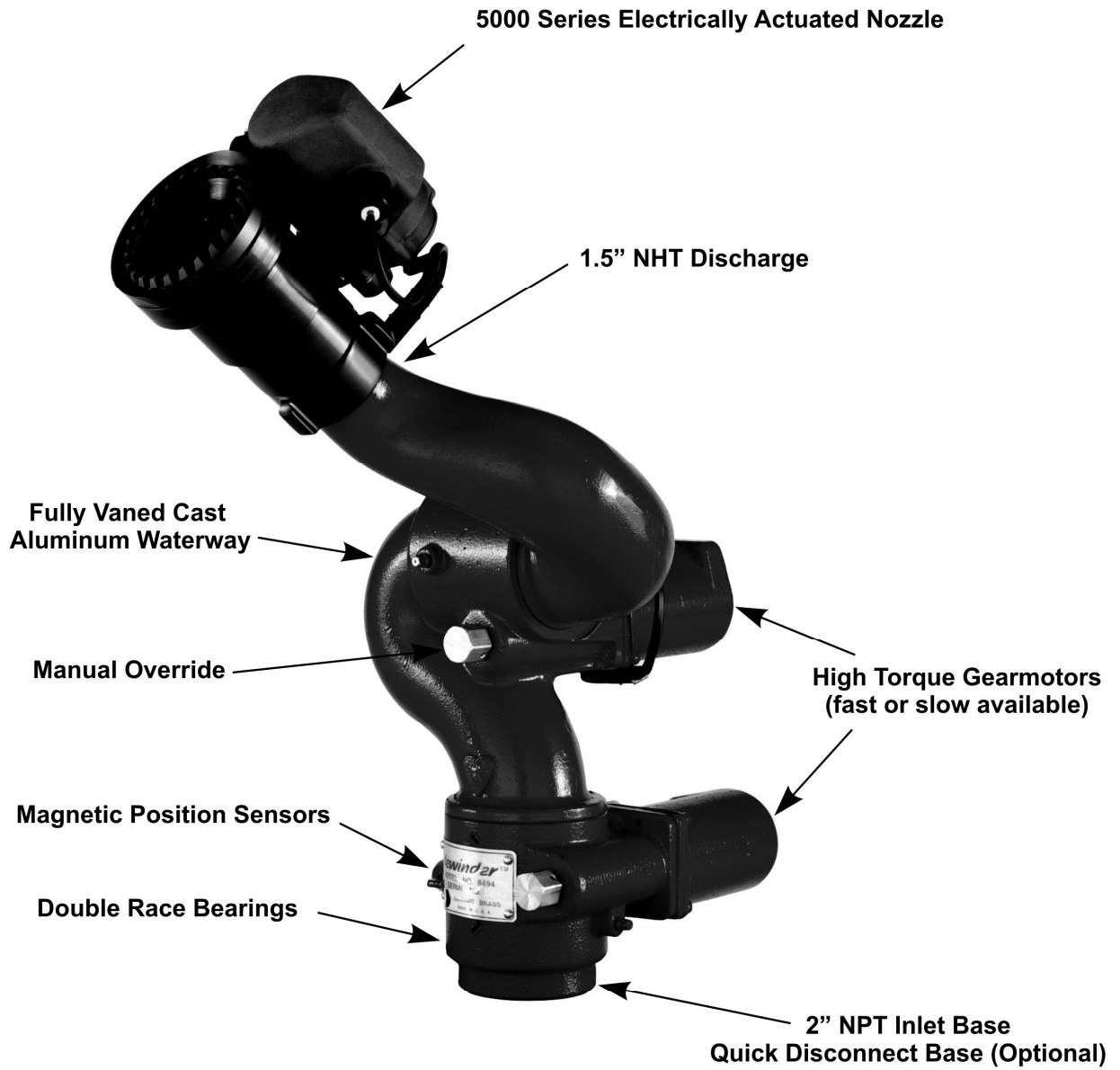

Figure 1
8494 *Sidewinder*™ Monitor

II. SYSTEM COMPONENT DESCRIPTIONS

A. *Sidewinder*[™] Monitor

The *Sidewinder*[™] Monitor is specially designed to mount on the front bumper of off-road or wildland fire fighting apparatus. It rotates either 180° or 334° to spray straight ahead or to either side for use in fighting forest, grass, range, brush and similar fires. In addition, because *Sidewinder*[™] is controlled from inside the cab, risk to firefighters is significantly reduced.

The *Sidewinder*[™] features durable Elk-O-Lite[®] construction combined with rugged, stainless steel gears and motors that are completely enclosed and sealed for maximum protection from the elements. The *Sidewinder*[™] has a flow efficient 2.0” vaned waterway to minimize turbulence and provide superior fire streams. Water supply is provided through the monitor base by 2” National Pipe Thread connection. The discharge nozzle connection is a 1½” National Hose Thread. Nozzle stream direction is controlled by two permanent magnet type gear motors, one controlling rotation about the axis of the water inlet, and the other controlling nozzle elevation and depression.

An optional 2.0” electric valve kit is available to allow the user to control water flow directly from the *Sidewinder*[™] control box. This enables “pump and roll” functionality with complete control by the operator in the cab of the truck.

B. 81713000 Control Module

The control module is completely encapsulated in epoxy for maximum protection from the elements. The module has reverse polarity protection to prevent damage to the electronic components. The module uses feedback from Hall effect sensors to determine when the monitor travel limits have been reached. It also uses dynamic braking to stop the motors for precision motion control.



Figure 2
81713000 Control Module

C. 81122001 Standard Control Box

The standard control box consists of a weather-tight enclosure with toggle switches that is suitable for mounting inside or outside the apparatus. The toggle switches control the water supply (On-Off), monitor direction (Left-Right and Up-Down), and nozzle pattern (Straight Stream-Fog).



Figure 3
81122001 Standard Control Box

D. 81172001 Joystick Control Box (Optional)

The joystick control box is suitable for mounting inside the apparatus cab. The joystick controls all four functions. The water supply is controlled with a trigger switch on the front of the joystick. The water can also be run continuously by activating the toggle switch mounted on the enclosure. Nozzle pattern is changed using the rocker switch on the top of the joystick. The monitor direction is changed by moving the joystick in the desired direction.



Figure 4
81172001 Joystick Control Box

E. 5000 Series Nozzles

Three constant flow electric nozzles are offered with the *Sidewinder*[™] monitor, with flows ranging from 15 to 350 GPM. The nozzle pattern is electrically actuated and controlled by the monitor control box.

Available in 12 VDC or 24 VDC.

5000-04; 15, 30, or 45 GPM

5000-14; 60, 95, 125, or 150 GPM

5000-24; 175, 200, 250, or 350 GPM



Figure 5
5000-24 Electrically Actuated Nozzle

F. 81181001 Water Valve Kit (Optional)

The *Sidewinder*[™] water valve kit provides a convenient remote on-off control of the water supply to the 8494 *Sidewinder*[™]. This allows the operator complete control of the unit from the safety of the vehicle cab. It also allows a “pump and roll” capability. The water valve motor prevents water hammer, yet closes quickly enough to help preserve the limited on-board water supply. The 81181001 Water Valve Kit is for **12VDC use only.** The 81298001 Water Valve Kit (24V) is available for use with 24VDC systems. It includes a 24-12 volt converter to power the water valve and control module.



Figure 6
2920E Electrically Actuated Valve

G. SM-10FE De/Anti-Icing Nozzle

Designed for the aircraft deicing industry, this nozzle has been designed for use with type 1 deicing, type 2 anti-icing, or type 4 anti-icing fluids. The SM-10FE has Viton[®] O-rings to withstand the use of the Ethylene Glycol and Propylene Glycol solutions used to de-ice aircraft. The nozzle is constant gallonage at pressures below 90 Psi and becomes automatic at 95 Psi. It is designed to deliver 20 GPM at 50 Psi and 30 –120 GPM from 90-110 Psi.

Available in 12 VDC or 24 VDC.



Figure 7
SM-10FE De/Anti-Icing Nozzle

III. CONTROL SYSTEM SPECIFICATIONS

A. Monitor Controller Specifications

- Power requirements 12VDC - 11VDC to 14VDC
24VDC - 22 VDC to 27 VDC
- Maximum Continuous Amps 12VDC - 5 A
24VDC - 2.5 A
- Peak Amps 12VDC - 14 A
24VDC - 7 A
- Operating temperature range -40°F to 176°F (-40°C to 80°C)
- Required inline fuse 12VDC - 10 A
24VDC - 5 A

B. Optional Valve Controller Specifications

- Power requirements 12VDC - 11VDC to 14VDC
24VDC - 22 VDC to 27 VDC
- Maximum Continuous Amps 12VDC - 5 A
24VDC - 2.5 A
- Peak Amps 12VDC - 14 A
24VDC - 7 A
- Operating temperature range -40°F to 176°F (-40°C to 80°C)
- Required inline fuse 12VDC - 10 A
(One fuse can be used to protect both the
monitor and valve controllers.) 24VDC - 5 A

Shock:

- 30 G's (55 Hz. @ .2 inch double amplitude)

Vibration:

- 15.5 G's (55 Hz. @ .05 inch double amplitude) continuous operation

Environmental:

- NEMA 4 rating (except 81172001 Joystick Assembly and 81122001 Switch Box Assembly) (must withstand a 1 inch stream of water (65 gpm) from a distance of ten feet for five minutes, with no water entering the enclosure).

IV. INSTALLATION INSTRUCTIONS

A. Component Mounting

1. *Sidewinder*[™] Monitor

Before mounting the Sidewinder[®] monitor, ensure that both the horizontal and vertical rotation envelopes are clear of all obstructions. See Figure 8 and Figure 9 for envelope dimensions. The rotation limits are determined by the magnet locations in the monitor body, and cannot be adjusted. (Exception: A 334° monitor can be made into a 180° monitor by adding two magnets through an access hole).

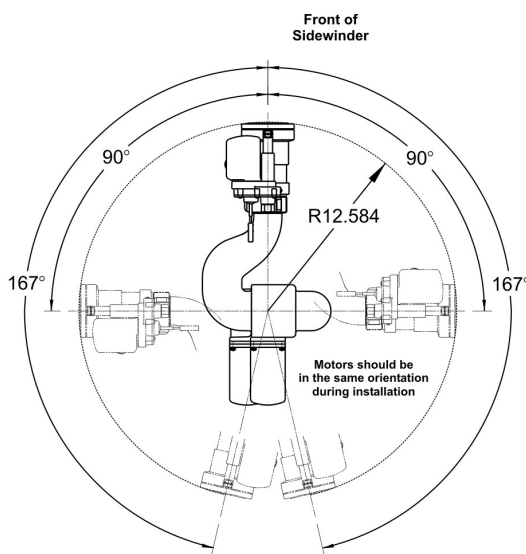

Figure 8
Horizontal Rotation Envelope

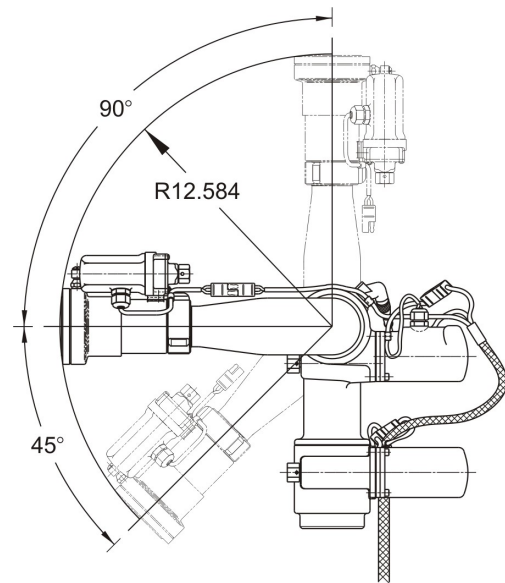

Figure 9
Vertical Rotation Envelope

- 1) Ensure the left-right and up-down motors are aligned as shown in Figure 8.
- 2) Mount the Sidewinder[®] monitor to a securely mounted 2.0" NPT threaded pipe (additional support may be necessary). The monitor can be mounted in any orientation, although some orientations will reverse the directions of movement relative to the control box.
- 3) Ensure that all of the electrical connections have been disconnected.
- 4) Apply a suitable thread sealant, thread the monitor onto the pipe connection, and tighten it securely with a strap wrench. Make sure the motor on the monitor base is facing away from the intended center of rotation. The rotation limits are determined by the magnet locations in the monitor body, and cannot be adjusted. (Exception: A 334° monitor can be made into a 180° monitor by adding two magnets through an access hole).
- 5) Reconnect the electrical connections according to Figure 16 and Figure 17. Check all of the electrical connections to make sure they are tight. Allow enough slack in the monitor harness to permit travel to the limits allowed by the controller without straining the wires.

2. 81713000 Control Module

The 81713000 control module is a rugged, watertight unit, allowing it to be installed anywhere within reach of the wiring harnesses. The cables should be routed away from any heat sources, and be protected from sharp corners. They should be tied down securely to prevent fretting or fraying due to vehicular vibrations. Securely mount the module to the vehicle. Connect the monitor connector to the monitor wiring harness. Connect the control connector to the wiring harness coming from the control box (or optional joystick). Connect the power connector to the fused power source. The control module can be supplied by either a 12 VDC or 24 VDC power source determined by monitor voltage requirements. See Section III.A. Monitor Controller Specifications.

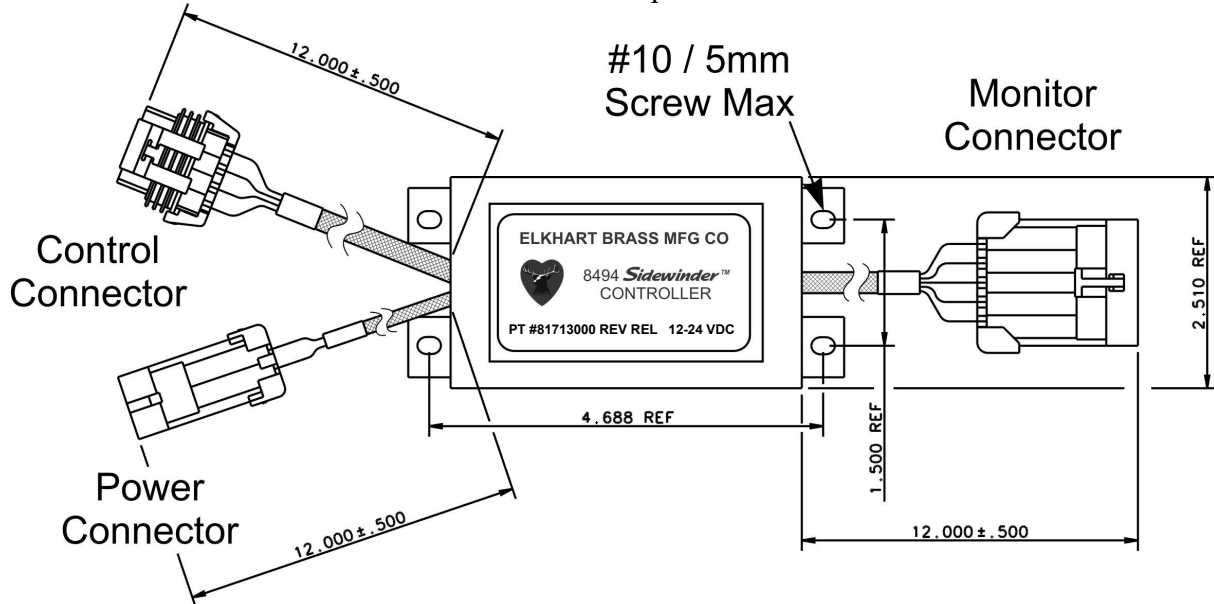

Figure 10
81713000 Control Module Mounting Layout Drawing

3. 81122001 Control Box & 81172001 Joystick Control Box (Optional)

The control boxes can be mounted using the mounting holes provided inside of the boxes. Any modification of the boxes themselves will void the Elkhart Brass warranty on the device. The connector attaching the wiring harness to the control box should be inserted straight into the mating connector on the box. Be sure to align the key with the keyway. There should be no need to force the connectors together. The locking ring on the connector will give a positive indication when it has locked to the connector body.

The control boxes should be mounted in a location where the wiring harness connecting to the box will have 2 - 3 inches of straight cable before beginning a bend (see Figure 13). This will remove stress from the connector, and prevent damage.

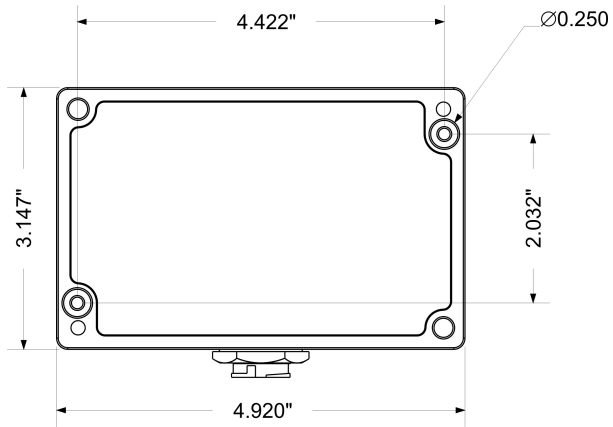

Figure 11
81122001 Control Box Mounting Layout

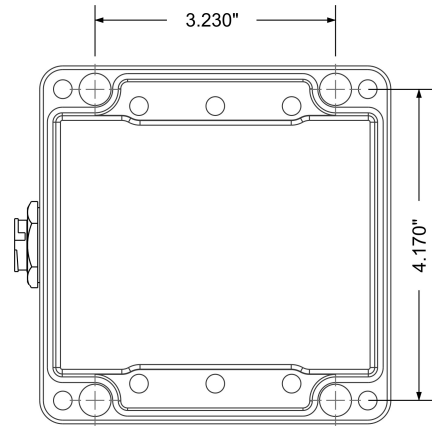

Figure 12
81172001 Joystick Mounting Layout



Figure 13
81172001 Joystick Cable Allowance

Do Not Stress Cable
 Allow 2-3 inches of straight
 cable before connection

4. 81181001 Water Valve Kit (Optional)

The 81181001 Valve Kit is for use with **12V DC systems ONLY**. To use the valve kit with a 24V system an 81298001 Water Valve Kit (24V) should be used.



Warning:

Using the 81181001 Water Valve Kit on a 24VDC system will damage the position sensors and burn out the motor. Elkhart Brass P/N 81298001 Water Valve Kit (24V) is the 24V replacement for the 81181001 Water Valve Kit.

Install the valve inline with the *Sidewinder™* monitor. Mount the 81196000 or 81294001 control module to the apparatus. The cables should be routed away from any heat sources, and be protected from sharp corners. They should be tied down securely to prevent fretting or fraying due to vehicular vibrations. Several optional cable lengths are available for the valve controller to allow it to be mounted in a convenient location. Connect the motor power and sensor lead to the valve harness. See Section III.B. Optional Valve Controller Specifications. Wire an inline fuse to the positive (red) lead of the control module (the same fuse that was used for the 81713000 can be used here). Connect the control connector to the free connector on the control harness.

Control Harness to Valve Module Extension Cables	
Part No.	Length
36779100	1ft
36779200	3ft
36779300	5ft
36779400	8ft
36779500	10ft
36779800	25ft

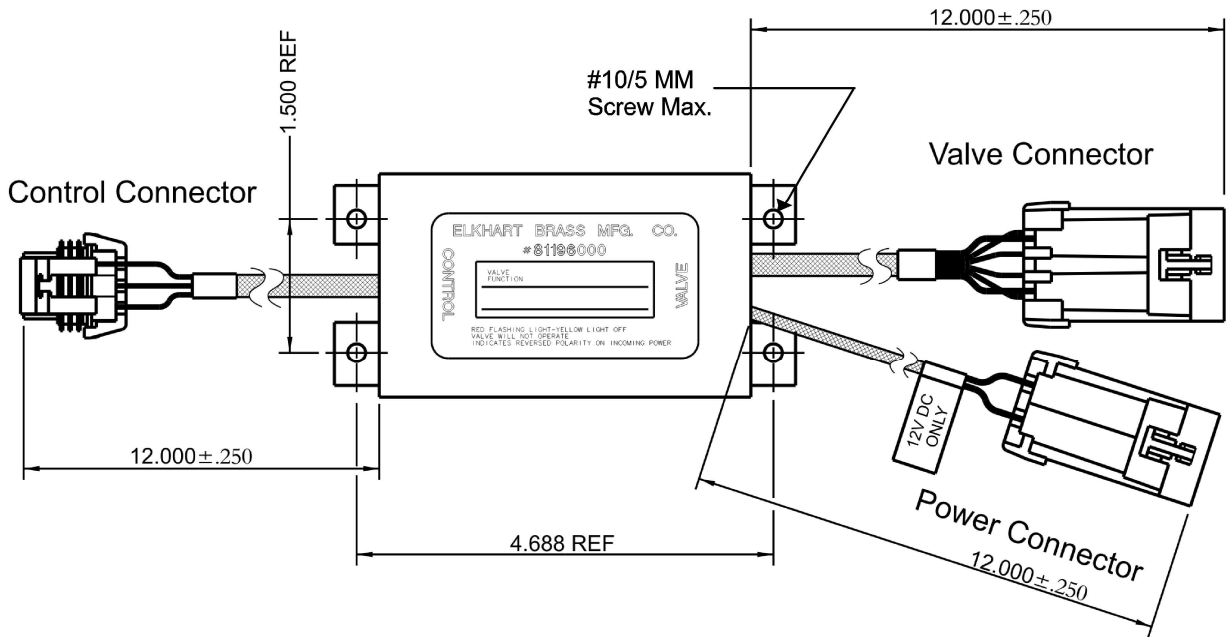

Figure 14

81196000 12 VDC Valve Control Module Layout

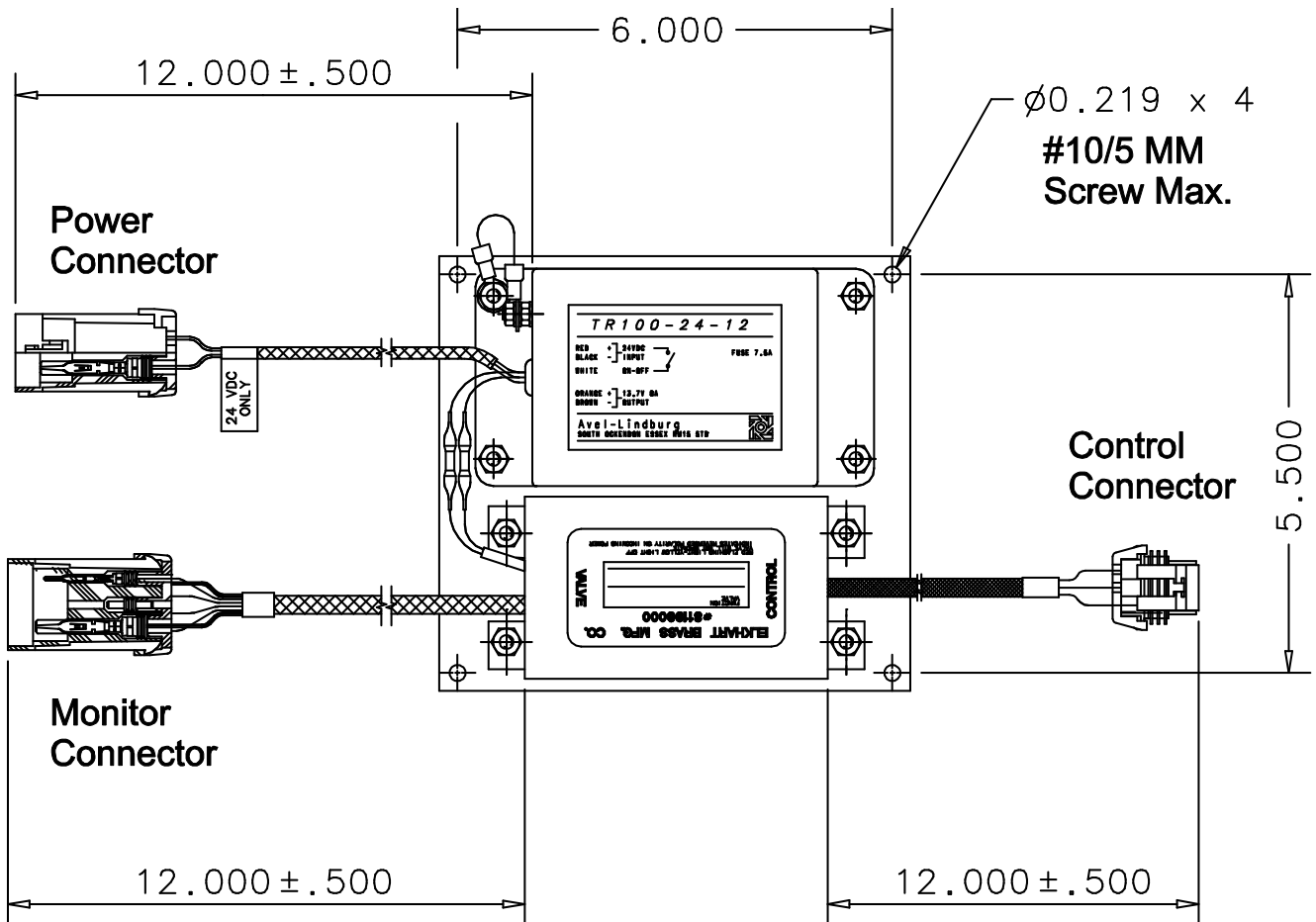

Figure 15

81294001 24 VDC Valve Control Module Layout

V. OPERATING INSTRUCTIONS

A. Normal Operation

1. 81122001 Standard Control Box

The monitor and nozzle are controlled with three toggle switches at each control point. These switches are marked “STRT-FOG”, “LEFT-RIGHT”, and “UP-DOWN”. The switches are of the three position, momentary contact, center-off type. Simply push and hold the switch(es) to move the monitor to the desired stream direction, or to adjust the nozzle to the desired spray pattern. Release the switch when the proper stream position or spray pattern is achieved. To flush the nozzle press the “FOG” switch. The nozzle will move to the wide fog position and continue on to the flush position. Use caution when the nozzle is in the wide fog position to not accidentally place the nozzle in the flush position. The 5000 Series and SM-10FE nozzles have a unique ball screw drive that allows motor to “free wheel” at the end of pattern travel in either the straight stream or wide fog positions. No slip clutch or current limiting feature is used with these nozzle drives. To flow water with the optional 81181001 or 81298001 Water Valve kits, place the “WATER” switch to water. This will completely open the valve. To close the valve place the “WATER” switch to off.

2. 81172001 Joystick Control Box

With the 81172001 Joystick Control Box, the monitor, nozzle and valve are controlled with the joystick and accompanying switches. Simply push and hold the joystick to move the monitor to the desired stream direction. Release the switch when the proper stream position is achieved. The nozzle spray pattern is controlled using the rocker switch on the top of the joystick. To flush the nozzle press the “FOG” switch. The nozzle will move to the wide fog position and continue on to the flush position. Use caution when the nozzle is in the wide fog position to not accidentally place the nozzle in the flush position. To continuously flow water with the optional 81181001 or 81298001 Water Valve kits, place the water valve switch to “ON”. This will completely open the valve and keep it open regardless of the lever position on the joystick. To close the valve place the water valve switch to “JOYSTICK” and let go of the joystick lever. To flow water for short durations leave the water valve switch in the “JOYSTICK” position and operate the valve with the lever on the front of the joystick. The valve will open as long as the lever is held in. When it is released, the valve will close.

B. Manual Override

In the event of power failure to one or more motors, the motor(s) may be actuated manually. To operate a function manually, simply apply a 3/4" ratcheting type wrench (either socket type or ratcheting box end type) to the hex fitting on the motor shaft extension. The left-right and up-down functions can be overridden much easier if the motor wire connector is unplugged from the control harness.



Caution:

Do not use impact drivers to operate the manual override nuts. Serious damage to the motor gearheads will result.

VI. MAINTENANCE

A. Preventive Maintenance

The complete monitor and control system should be inspected during each apparatus check. Careful inspection for damage to the monitor or nozzle is especially important after use of the *Sidewinder™* Monitor in emergency operations.

1. Operate each function (left-right, up-down, str-t-fog) from each control point.
2. Flow water to check the nozzle pattern. If the pattern is disrupted, use the nozzle flush feature to clear the debris. If the obstruction still remains, remove the nozzle and check for debris lodged between the nozzle stem and body.
3. During nozzle flow test, inspect monitor swivel joints for leaks.
4. Inspect all exposed wiring for signs of damage.

Note: Grease fittings are provided for the up-down and left-right rotation joints, routine greasing should be performed to expel water & other contaminants that can get into the rotation joints. If the monitor is exposed to a high level of radiant heat for a prolonged period, it may be possible for the factory grease to thin and run out of the rotation joints. In such an event, fresh grease should be applied. Use Mobilux EP2 or equivalent. Start at one end of travel range and apply grease through the fitting of each joint until fresh grease comes out the joint. Repeat every 30 degrees throughout the full range of travel on each rotation joint. Wipe off any expelled grease when done.

VII. PARTS DRAWINGS

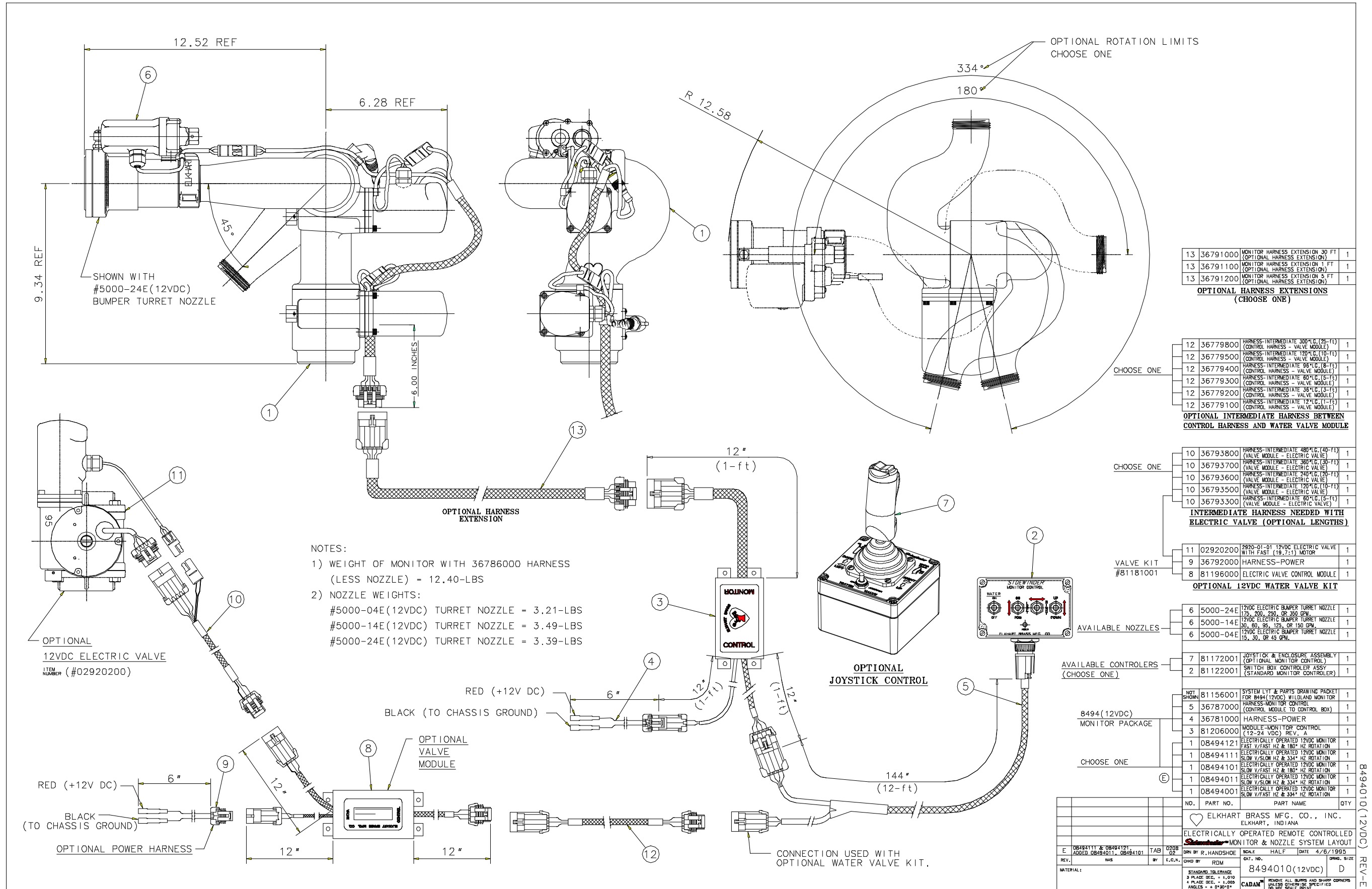

Figure 16
8494 12VDC Layout

98184000 REV-E

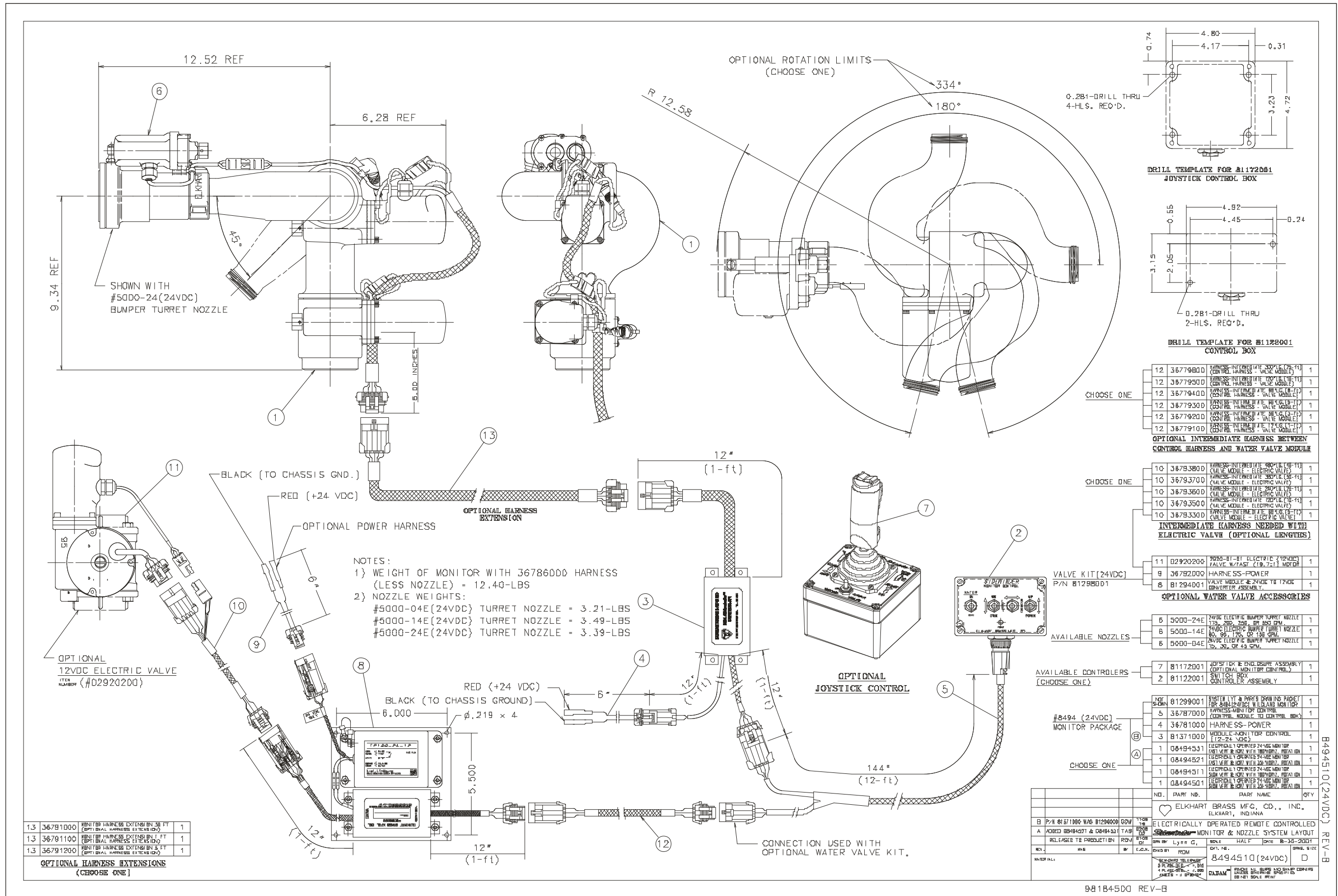
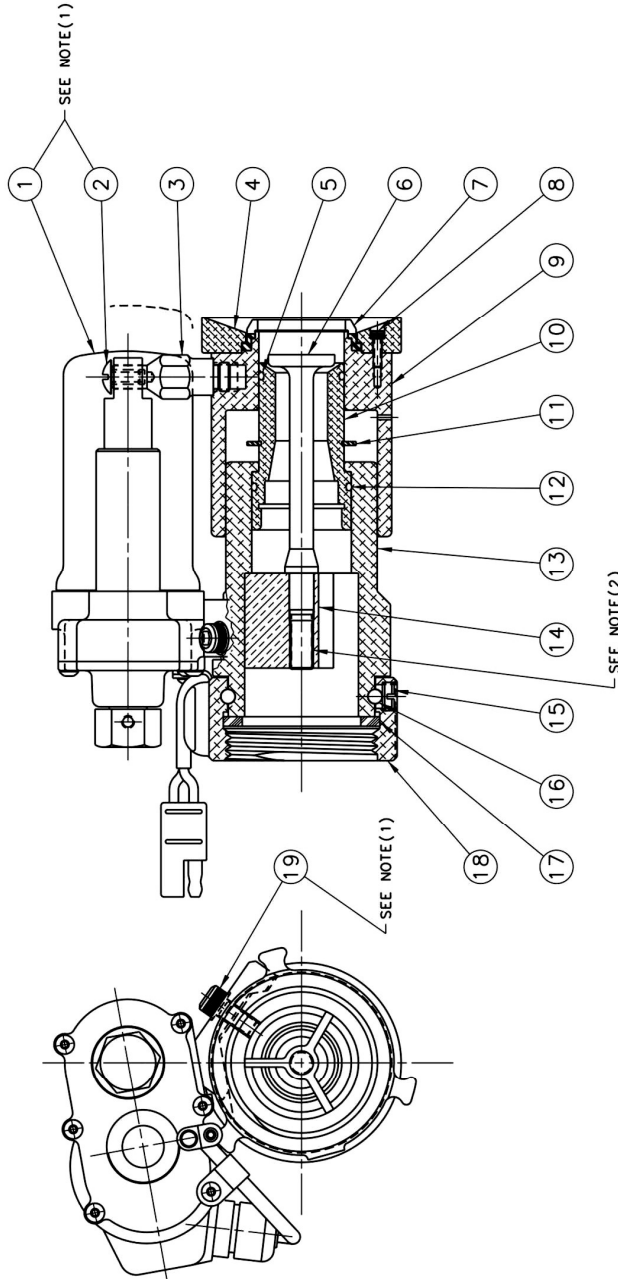

Figure 17
8494 24VDC Layout

PARENT NO.'S.:	12-VDC	(30-GPM)	NOZZLE
05000041	12-VDC	(30-GPM)	NOZZLE
05000042	12-VDC	(15-GPM)	NOZZLE
05000043	12-VDC	(45-GPM)	NOZZLE
05000044	24-VDC	(30-GPM)	NOZZLE
05000045	24-VDC	(15-GPM)	NOZZLE
05000046	24-VDC	(45-GPM)	NOZZLE

NOTES:
 (1) SECURE THREADS WITH *LOCTITE* ADHESIVE #242 (BLUE).
 (2) SECURE THREADS WITH *LOCTITE* ADHESIVE #262 (RED).



6	62061001	STEM-NOZZLE (45-G.P.M.)	1
6	62060001 <th>STEM-NOZZLE (30-G.P.M.)</th> <th>1</th>	STEM-NOZZLE (30-G.P.M.)	1
6	62059001 <th>STEM-NOZZLE (15-G.P.M.)</th> <th>1</th>	STEM-NOZZLE (15-G.P.M.)	1

OPTIONAL STEMS (USE ONE)

19	61040000	SCREW CAP (#300-SER. S/S)	1
18	63068001	SWIVEL, R/L 0.786	1
17	33074000	CASKY W/REBAR	1
16	15018000	BALLS-0.187 DIA. S/S 32	1
15	63674000	SET SCREW (BLACK TEF/ON)	1
14	63418001	BASE-STEM (WEB)	1
13	17152001	BODY-NOZZLE	1
12	57337000	RING-O (AS-568-025)	1
11	57684000	RING-RETAINER #070-H	1
10	16903001	BARREL-CENTER	1
9	66385001	TIP-NOZZLE	1
8	63780000	CAP SCREW (STNLS S/L)	2
7	58872000	TEETH RING (SPINNING)	1
5	57329000	RING-O (AS-568-025)	1
4	57612001	RETAINER RING (TEETH)	1
3	17729001	BRACKET - PUSH ROD	1
2	61078000	SCREW - CAP (300-SER) S/S	1
1	81226001	24-VDC ELEC. NZL. ACTUATOR ASS'Y.	1
1	81197001	12-VDC ELEC. NZL. ACTUATOR ASS'Y.	1

USE ONE PER VOLTAGE (SEE PARENT NUMBER)

NO.	PART NO.	PART NAME	REQ.
ELKHART BRASS MFG. CO., INC. ELKHART, INDIANA			
ELECTRICALLY OPERATED BUMPER TURRET NOZZLE			
RELEASED TO PROD.		SCALE FULL	DATE 11-26-96
REV.	BY	CHKD BY	CAT. NO.
MATERIAL:			5000-04E C
STANDARD TOLERANCE			DWG. SIZE
3 PLACE DEC. ± 0.010			11" X 17" (A)
UNLESS OTHERWISE SPECIFIED			CAD/M
ANGLES ± 1° 30' 00"			

Figure 18
5000-04 Parts Drawing

PARENT NUMBER (SEE NOTE) 5000-14E REV.C

PARENT NO.'S.:

05000141	12-VDC	(95-GPM)	NOZZLE
05000142	12-VDC	(60-GPM)	NOZZLE
05000143	12-VDC	(125-GPM)	NOZZLE
05000144	12-VDC	(150-GPM)	NOZZLE
05000145	24-VDC	(95-GPM)	NOZZLE
05000146	24-VDC	(60-GPM)	NOZZLE
05000147	24-VDC	(125-GPM)	NOZZLE
05000148	24-VDC	(150-GPM)	NOZZLE

NOTES:

(1) SECURE THREADS WITH "LOCTITE" ADHESIVE #242 (BLUE).

(2) SECURE THREADS WITH "LOCTITE" ADHESIVE #262 (RED).

(3) BODIES STAMPED WITH "X" IDENTIFY CORRECTED FLOW RATE.

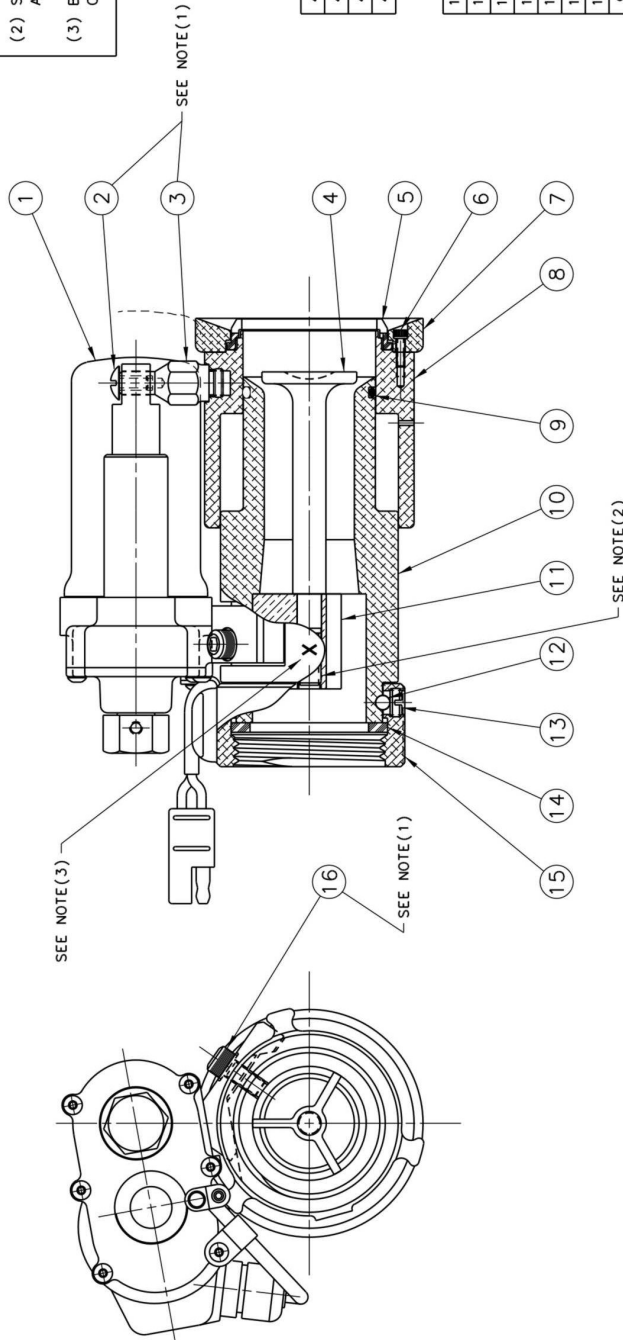

4	62051001	STEM-NOZZLE (150-G.P.M.)	1
4	62050001	STEM-NOZZLE (125-G.P.M.)	1
4	62049001	STEM-NOZZLE (95-G.P.M.)	1
4	62047001	STEM-NOZZLE (60-G.P.M.)	1

OPTIONAL STEMS (USE ONE)

16	61040000	SCREEN-CAP (100-SER) 5/8" S/S	1
15	63068001	SWIVEL-3 R/L O/RBS 3/8" SOC-HD	1
14	33074000	CARET-RUBBER (N) 1.5 N.H. THREAD	1
13	63674000	SET SCREW (BLACK TEFLOM) 0.375-24 X 0.156 LG.SLT.HD	1
12	15018000	BALLS-0.187 DIA. S/S 32	1
11	63418001	BASE-STEM (WEB)	1
10	117151001	BODY-NOZZLE	1
9	57398000	O-RING (AS 568-128) 1.487-I.D. X 0.103-W.	1
8	66384001	TIP-NOZZLE	1
7	57618001	RETAINER RING (TEETH)	1
6	63780000	SCREW (S/S) 1/4-40 X 0.375 LG. SOC. HD.	3
5	58870000	TEETH RING (SPINNING)	1
3	117812001	BRACKET - PUSH ROD	1
2	61078000	SCREEN - CAP (100-SER) 5/8" 1/0-32 X 0.250-LG. TRUSS SLT.HD.	1
1	81226001	24-VDC ELEC.NZL.ACTUATOR ASS'Y.	1
1	81197001	12-VDC ELEC.NZL.ACTUATOR ASS'Y.	1

USE ONE PER VOLTAGE (SEE PARENT NUMBER)

NO.	PART NO.	PART NAME	REQ.
ELKHART BRASS MFG. CO., INC. ELKHART, INDIANA			
ELECTRICALLY OPERATED BUMPER TURRET NOZZLE			
(60, 95, 125 OR 150 GPM)			
REV.	DATE	BY	CHK'D
1	12-11-96	RDW	
STANDARD TOLERANCE: 3 PLACE DEC. ± 0.010			
FINISH: UNLESS OTHERWISE SPECIFIED			
ANGLES: 45°/30°/0°			
MATERIAL: CADAM			
REMOVE ALL BURRS AND SHARP CORNERS			
5000-14E C			
SOLE FULL DATE			
DRAWN: 12-11-96			

WEIGHT: 3.25- lbs.

PARENT NUMBER (SEE NOTE) 5000-14E REV.C

Figure 19

5000-14 Parts Drawing

PARENT NO.'S.:

05C00239	12-VDC (475-GPM)	NOZZLE
05C00240	12-VDC (400-GPM)	NOZZLE
05C00241	12-VDC (350-GPM)	NOZZLE
05C00242	12-VDC (250-GPM)	NOZZLE
05C00243	12-VDC (200-GPM)	NOZZLE
05C00244	12-VDC (175-GPM)	NOZZLE
05C00245	24-VDC (350-GPM)	NOZZLE
05C00246	24-VDC (250-GPM)	NOZZLE
05C00247	24-VDC (200-GPM)	NOZZLE
05C00248	24-VDC (175-GPM)	NOZZLE
05C00249	24-VDC (400-GPM)	NOZZLE
05C00250	24-VDC (475-GPM)	NOZZLE

NOTES:
 (1) SECURE THREADS WITH *LOCTITE* ADHESIVE #242 (BLUE).
 (2) SECURE THREADS WITH *LOCTITE* ADHESIVE #262 (RED).

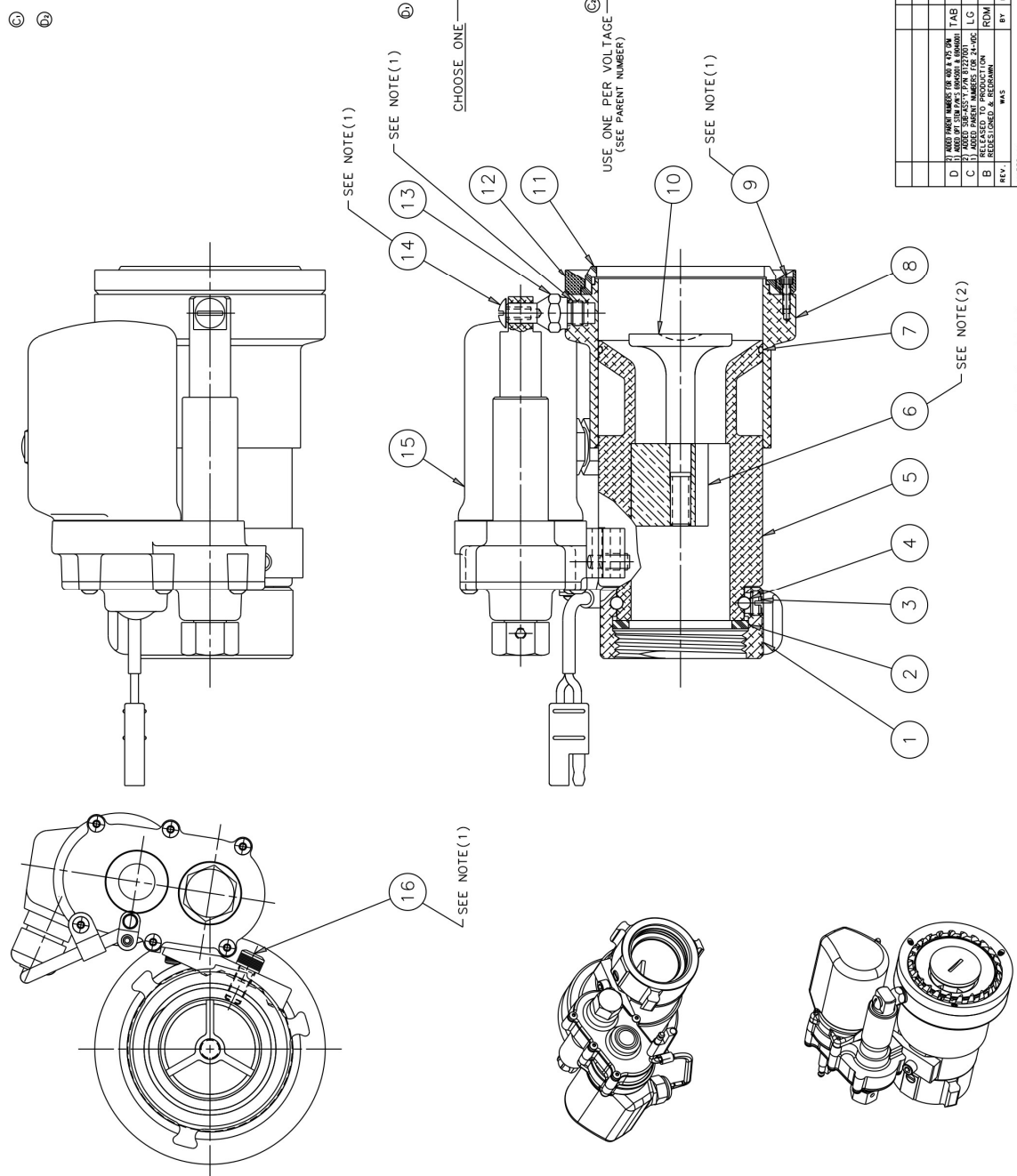

10	69046001	STEM-NOZZLE (475 GPM)	1
10	69045001	STEM-NOZZLE (400 GPM)	1
10	62172001	STEM-NOZZLE (350 GPM)	1
10	62171001	STEM-NOZZLE (250 GPM)	1
10	62181001	STEM-NOZZLE (200 GPM)	1
10	62180001	STEM-NOZZLE (175 GPM)	1

AVAILABLE STEMS RATED AT 100 PSIG

16	61040000	SCREW-CAP (#300-SEK. S/S) 0.250-20 X 0.500-LG. SOC. HD.	1
15	81227001	24-VDC ELEC. NZL. ACTUATOR ASS'Y.	1
15	81186001	12-VDC ELEC. NZL. ACTUATOR ASS'Y.	1
14	61078000	SCREW - CAP (#300-SEK) S/S #10-32 X 0.250-LG. BRASS S/LI. HD.	1
13	17813001	BRACKET - PUSH ROD	1
12	57631001	RETAINER RING (TEETH)	1
11	58875000	TEETH RING (SPINNING)	1
9	63780000	CAP SCREW (STNLS STL) #4-40 X .375-LG. SOC. HD.	3
8	66375001	TIP-NOZZLE	1
7	57477000	O-RING (AS 568-036) 2.364-ID X 0.070-W	1
6	63418001	BASE-STEM (WEB)	1
5	17149001	BODY-NOZZLE	1
4	15018000	BALLS-0.187 DIA. S/S 32	1
3	63674000	SCREW (BLACK TEFLO) #3-48 X .187-LG. S/LI. HD.	1
2	33074000	CASKE-RUBBER (NH) 2.062-OD X 1.562-ID X 0.187-TKH	1
1	63068001	WASHER (STNLS) #3-48 X .187-LG. S/LI. HD.	1
1	63068001	1.5 IN. H. THREAD	1

NO.	PART NO.	PART NAME	REQ.
ELKHART BRASS MFG. CO., INC. ELKHART, INDIANA			
ELECTRICALLY OPERATED BUMPER TURRET NOZZLE (175, 200, 250, 350, 400, OR 475 GPM)			
FORM BY:	670122024	SCALE: FULL	DATE: 9-25-96
CHKD BY:		DATE:	
STANDARD TO EXCEED:			
1. PLACE REC. # 8016			
2. PLACE REC. # 8016			
3. PLACE REC. # 8016			
4. PLACE REC. # 8016			
5. PLACE REC. # 8016			
6. PLACE REC. # 8016			
7. PLACE REC. # 8016			
8. PLACE REC. # 8016			
9. PLACE REC. # 8016			
10. PLACE REC. # 8016			
11. PLACE REC. # 8016			
12. PLACE REC. # 8016			
13. PLACE REC. # 8016			
14. PLACE REC. # 8016			
15. PLACE REC. # 8016			
16. PLACE REC. # 8016			
MATERIAL:			
WEIGHT: 3.25-lbs.			
CADA# 1 UNLESS OTHERWISE SPECIFIED			
DO NOT SCALE PRINT			

Figure 20
5000-24 Parts Drawing

8494 Sidewinder™

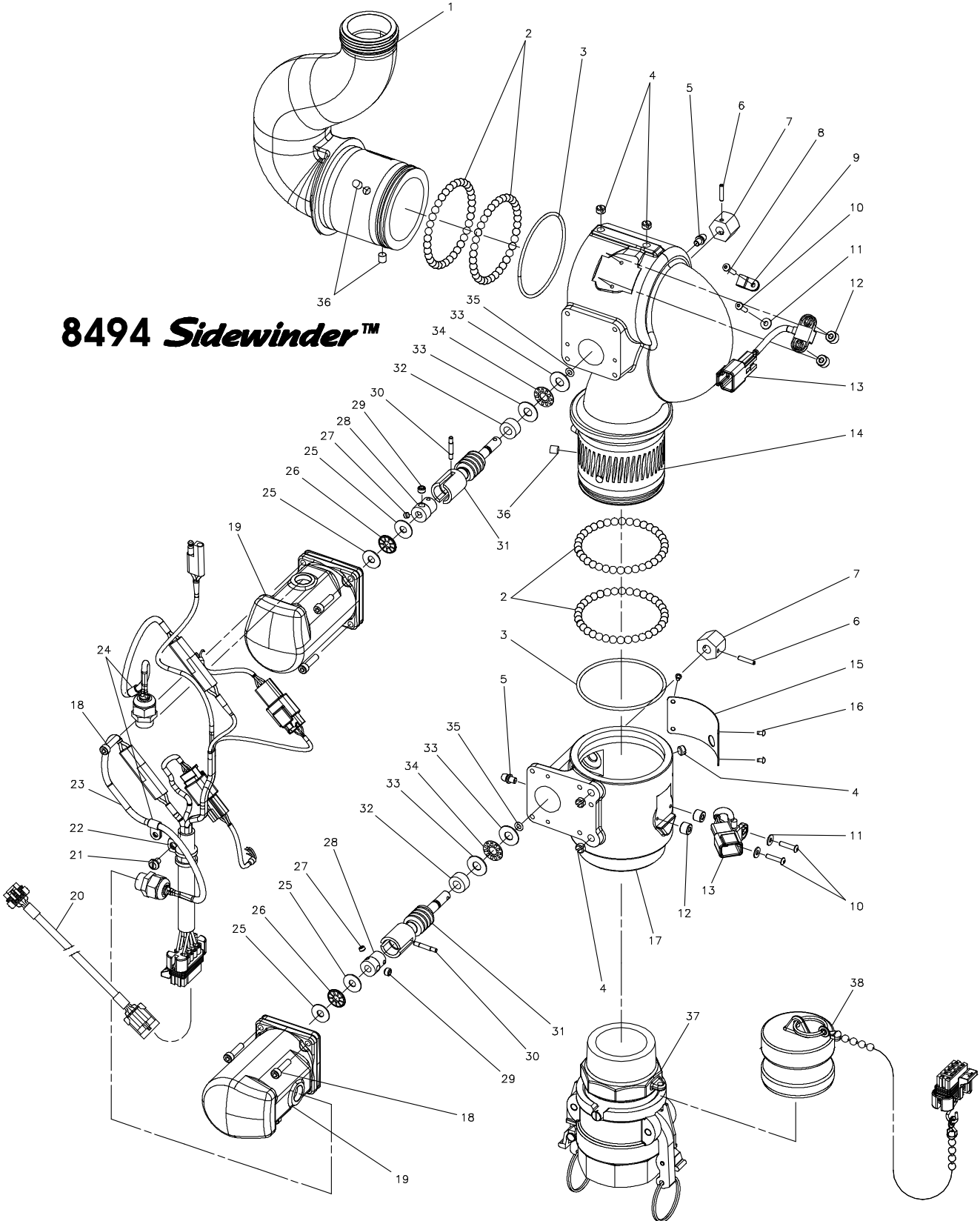

8494 SIDEWINDER MONITOR PART LIST			
IND.#	PART #	QTY	PART DESCRIPTION
1	17908001	1	MONITOR OUTLET BODY
2	15027000	144	BALLS-0.250 DIA. SS (36 PER RACE)
3	57502000	2	O-RING AS 568-148F (2.737 ID X 0.103 C/S)
4	63687000	5	SET SCREW 0.312-18 X 0.187 LG BLK NYLON
5	31011000	2	GREASE FITTING (SS)
6	51248000	2	ROLL PIN 0.125 DIA. X 0.625 LG SS
7	47652001	2	OVER-RIDE NUT
8	65140000	1	SCREWS #6-32 X 0.750 LG SOC BTN HD SS
9	23572000	1	CLAMP LOOP (NYLON) 0.140 HOLE
10	65139000	3	SCREWS #6-32 X 0.625 LG SOC BTN HD SS
11	71176000	3	WASHER - #6 SS
12	65572000	4	SPACER - SENSOR
13	65104000	2	POSITION SENSOR
14	18219001	1	MONITOR INLET BODY
15	44339000	1	SERIAL NO./IDENTIFICATION PLATE
16	61215100	4	DRIVE SCREW #4 X 0.187 RND HD SS
17	17975001	1	MONITOR BASE (2.0 NPT FEMALE)
18	64072000	8	CAP SCREWS #10-32 X 0.500 LG SOC HD SS
19	81119001	2	MOTOR ASSY (12 VDC SLOW)
19	81147001	2	MOTOR ASSY (12 VDC FAST)
19	81207001	2	MOTOR ASSY (24 VDC SLOW)
19	81240001	2	MOTOR ASSY (24 VDC FAST)
20	36791200	1	QUICK CONNECT HARNESS EXTENSION
21	63797000	1	SCREW #10-32 X 0.250 LG SLT PAN HD SS
22	23570000	1	CLAMP LOOP CUSHIONED
23	36833100	1	MONITOR CONTROL HARNESS
24	23571000	2	CLAMP LOOP (NYLON) 0.210 HOLE
25	71515000	4	THRUST WASHER 1/4
26	17701000	2	THRUST BEARING 1/4
27	65201000	2	SET SCREW #10-32 X 0.125 LG SOC HD SS
28	20991001	2	COUPLING
29	65219000	2	SET SCREW #10-32 X 0.187 LG SOC HD SS
30	51071000	2	SOLID PIN (DRIVE LOCK E) 0.125 DIA X 0.875LG
31	63935001	2	WORM SHAFT SS
32	63601001	2	SPACER
33	71516000	4	THRUST WASHER 5/16
34	17702000	2	THRUST BEARING 5/16
35	57380000	2	O-RING AS 568-008 (0.176 ID X 0.070 C/S)
36	46054000	4	MAGNETS
OPTIONAL QUICK CONNET CPLG ASSY			
37	81342001	1	QUICK CONNECT COUPLING
OPTIONAL FOR USE WITH P/N 81342001 QUICK CONNECT ADAPTER			
38	81342051	1	DUST PLUG ASSY WITH CHAIN



Elkhart Brass

Fire Fighting Equipment

Elkhart Brass Mfg. Co., Inc.

Mailing Address:

P.O. Box 1127

Elkhart, IN 46515 USA

Shipping Address:

1302 W. Beardsley Ave.

Elkhart, IN 46514 USA

Tel. 1-574-295-8330

1-800-346-0250

Fax 1-574-293-9914

e-mail: info@elkhartbrass.com

www.elkhartbrass.com