

# SM-100

Pre '02

Index No.	Part No.	Qty. Per Unit	Description
1	33644000	1	Hand Grip
2	80843001	1	Stem Sub-Assembly
3	66383001	1	Nozzle Tip
4	61087001	1	Cam Screw
5	63674000	1	Set Screw
6	61163000	3	Machine Screw
7	71231001	1	Hand Wheel
8	57456000	1	"O"-Ring
9	17121001	1	Nozzle Body (Tip)
10	57414000	1	"O"-Ring
11	57416000	1	"O"-Ring
12	33710001	1	Stem Guide
13	17150001	1	Nozzle Body (Base)
14	44320000	1	Identification Label
15	61774000	1	Coil Spring
16	63895001	1	Sleeve
17	71111001	1	Reinforcing Washer
18	63409001	1	Stem (Web) Base
19	47474000	1	Jam Nut
20	57308000	1	"O"-Ring
21	10611001	1	3.5" B/G Adapter Base
21A	10610001	1	2.5" B/G Adapter Base
22	15018000	**	.187" S/S Ball
23	63018001	1	3.5" R/L Swivel
23A	63069001	1	2.5" R/L Swivel
24	63675000	1	Set Screw (3.5" Swivel)
24A	63674000	1	Set Screw (2.5" Swivel)
25	33186000	1	Rubber Gasket (3.5" Swivel)
25A	33083000	1	Rubber Gasket (2.5" Swivel)

\*\* 71 balls for 3.5" Swivel; 52 balls for 2.5" swivel

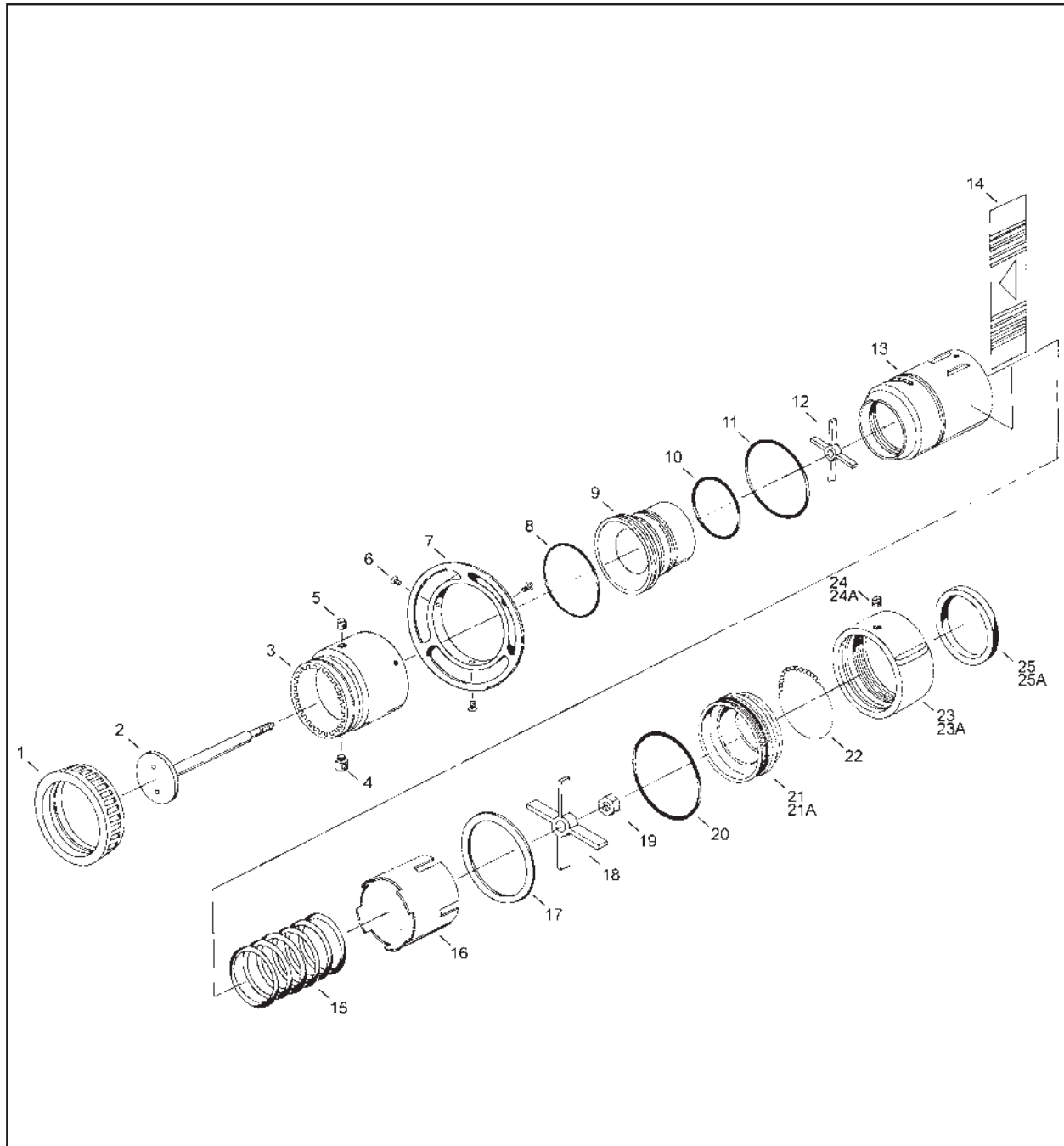

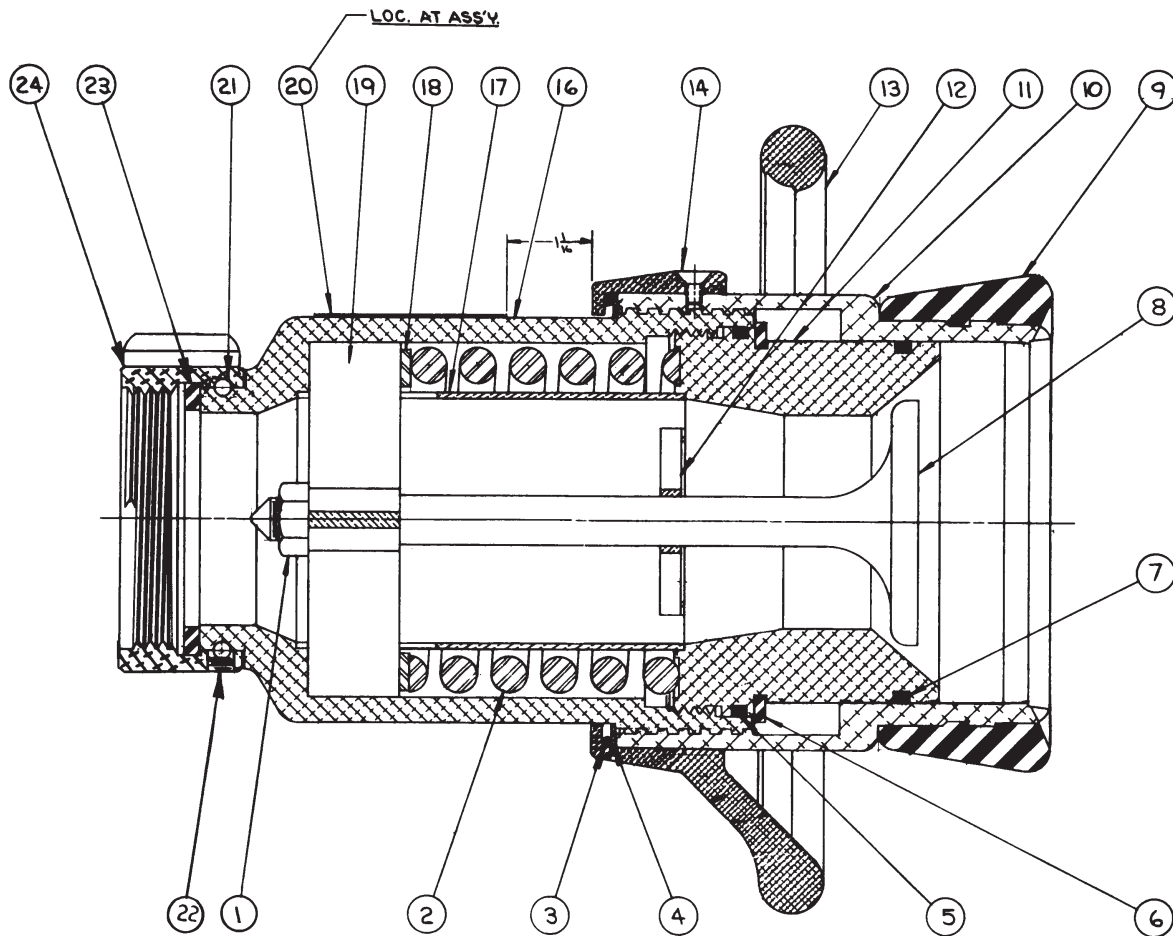

TIP TRAVEL -  $\frac{1}{8}$   
STEM TRAVEL -  $\frac{1}{16}$  APPROX.

24	63069-B	SWIVEL - O R/G, 3-R/L	1
23	33083	2.5 N.H.T. - 3.125 TMD	1
22	63674	GASKET - RUBBER	1
21	23002-A	PG-124	1
20	51733-A	3.187-O.D. x 2.562-I.D. x .187	1
19	63371-B	SCREW - SET (SLOTTED)	1
18	71111-A	375-24 x .187 BRASS PLASTIC	1
17	61633-B	CHAIN - B/G (11.625-LG.)	1
16	15886-C	PLATE - INDICATOR	1
15		STEM - BASE	1
14	61163	WASHER - REINF.	1
13	71228-C	SCREW - MACH. (BYNLS 30)	3
12	33710-A	*10-32 x .875 SOC. FLMT. HD.	1
11	15887-B	WHEEL - HANDLE	1
10	66267-C	GUIDE - STEM	1
9	33635-A	BODY (TIP) - NOZZLE	1
8	80149-B	TIP - NOZZLE	1
7	57316	RING - O	1
6	33231-A	4.000-I.D. x 4.250-O.D. x .125-TM	1
5	57308	GASKET - RUBBER	1
4	71112-A	4.250-I.D. x 4.500-O.D. x .125-TM	1
3	57363	RING - O	1
2	61774-A	5.000-I.D. x 5.250-O.D. x .125-TM	1
1	47474	SPRING - COIL	1
		NUT - JAM $\frac{1}{2}$ -20 (NVLCK)	1

C	PT 47474 REP 47540	F A 6	7710	OF	
B	63674 REP 61332	F A 6	7707	OF	
A	PT 63069 REP PT 63055	F A 6	7707	OF	
	PT 33635-A WAS PT 33635-A	F A 6	7707	OF	
	RELEASED TO PROD.	F A 6	7707	OF	

REV	WAS	BY	DATE	CHKD BY	APPD BY

NO.	PART NO.	PART NAME	REQ.

**ELKHART BRASS MFG. CO., INC.**  
ELKHART, INDIANA

**SELECT-O-MATIC NOZZLE**  
1000-G.P.M. @ 100-P.S.I.

DRN BY: L. GLOTZBECK  
SCALE: FULL  
DATE: 6-26-70

CAT. NO. **SM-100**

FRACTIONS:  $\frac{1}{8}$  .125  
DECIMALS:  $\frac{1}{16}$  .0625  
ANGLES:  $\frac{1}{4}$  45°

REMOVE ALL BURRS AND SHARP CORNERS UNLESS OTHERWISE SPECIFIED DO NOT SCALE PRINT

D	PT 71228 REP 61332	F A 6	7707	OF	
	100 MANUFACTURED BY ELKHART BRASS MFG. CO.	F A 6	7707	OF	

# SM-100 & SM-100H

(Old Style - Pre '85)

---

April, 1996

PART NO.	QUANTITY PER UNIT	DESCRIPTION
47540	1	Jam Nut
61774	1	Coil Spring
57363	1	"O" Ring
71112	1	Washer-reinfor.
57308	1	"O" Ring
33231	1	Rubber Gasket
57316	1	"O" Ring
80149	1	Stem Assembly
33635	1	Hand Grip
66267	1	Nozzle Tip
15887	1	Nozzle Body (Tip)
33710	1	Stem Guide
71221	1	Hand Wheel O/S (Pre '79)
71228	1	Hand Wheel N/S
61163	3	Machine Screw
61666	1	Sleeve Indicator
15886	1	Nozzle Body (Base)
61633	1	Sleeve
71111	1	Washer-reinfor.
63371	1	Stem Base
51733	1	Plate Indicator
23002	1	Chain B/G
61222	1	Set Screw
33083	1	Rubber Gasket
62919	1	2.5" Swivel

## SM-100H Parts

15898	1	Nozzle Body (Base)
66273	1	Nozzle Tip
57385	1	"O" Ring
23029	1	Hydraulic Cylinder
61073	2	Cap Screw For Cylinder
16514	1	Angle Bracket
63781	2	Cap Screw For Bracket
47544	2	Jam Nut

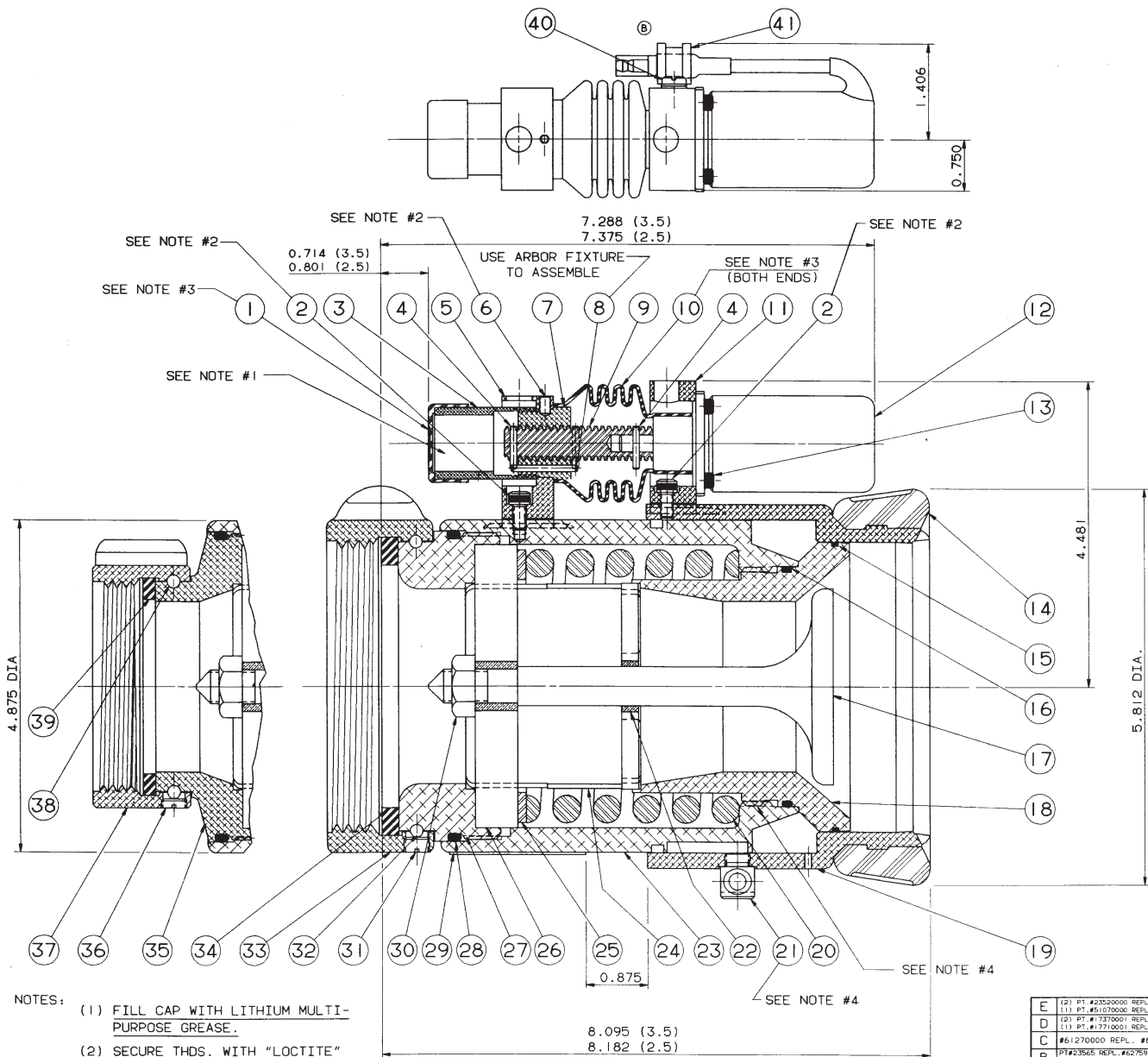

- NOTES:
- (1) FILL CAP WITH LITHIUM MULTI-PURPOSE GREASE.
  - (2) SECURE THDS. WITH "LOCTITE" ADHESIVE #242(BLUE).
  - (3) SECURE WITH "LOCTITE" SUPER BOND #416.
  - (4) SECURE THDS. WITH "LOCTITE" ADHESIVE #262(RED).

39	33083000-A	GASKET - RUBBER (NST)	3.187-0.D.X 2.562-I.D.X 0.187 THK	1
38	15018000-A	BALL (0.187-DIA.) S/S		52
37	63069001-B	SWIVEL-OB/G, 3-R/L		1
36	63674000-A	SCREW - SET (BLACK TEFLON)	0.375-24 X .156-LG. SLT.HD.	1
35	10610001-B	ADAPTER-BASE (2.5-OB/G)		1
PARENT NUMBER (#03781001) PARTS FOR 2.5-SWIVEL INLET				

34	33186000	GASKET - RUBBER (NST)	4.375-0.D.X 3.562-I.D.X 0.250 THK	1
33	63018001-A	SWIVEL-B/G, 2-R/L	3.500 - N.H.TH.D.	1
32	15018000-A	BALL (0.187-DIA.) S/S		71
31	63675000-A	SCREW - SET (BLACK TEFLON)	.375-24 X .312-LG. SLT.HD.	1
27	10611001-B	ADAPTER-BASE (3.5-B/G)		1
PARENT NUMBER (#03781101) PARTS FOR 3.5-SWIVEL INLET				

(B)	41	23565000-A	CLAMP-LOOP CUSHIONED	1
	40	63797000	CAP - SCREW (STNLS. STL.) #10-32 X 0.250-LG. SLOTTED PAN HEAD	1
	29	52151000-A	LABEL - INDICATOR	1
	30	47474000	NUT - JAM (0.500-20)	1
	28	57308000	RING - O (#AS 568 - 244)	1
	26	63409001-A	STEM (WEB) BASE	1
	25	71111000-A	WASHER - REINF.	1
	24	63895001-A	SLEEVE	1
	23	17118001-C	BODY (BASE) NOZZLE	1
	22	33710001-A	GUIDE - STEM	1
(F)	21	65051001-A	SCREW-CABLE (S/S)	1
	20	61774000-A	SPRING - COIL	1
	19	66349001-C	TIP - NOZZLE	1
(A)	18	17121001-B	BODY (TIP) NOZZLE	1
(A)	17	80843001-B	STEM SUB-ASS'Y.	1
	16	57414000	RING - O (#AS 568 - 152)	1
	15	57456000	RING - O (#AS 568 - 045)	1
	14	33644000-B	GRIP - HAND	1
	13	63796000	SCREW-CAP (#300-SER. S/S) #6-32 X 0.250-LG. SOC.HD.	4
	12	46036001-A	MOTOR - ELECTIC	1
(D)	11	17710001-A	BRACKET-MOTOR (N/S)	1
(E)	10	23520000-A	COVER-SHAFT (RUBBER)	1
	9	61283001-A	SCREW - SHAFT	1
	8	51259000-A	PIN - ROLL (#400 SER. S/S) 0.094-DIA.X 1.000-LG.	1
	7	16664001-A	BUSHING - THREAD	1
(C)(B)	6	61270000	SCREW - SET (#300-SER. S/S) #8-32 X 0.250-LG.	1
(D)	5	17370001-A	BRACKET-SHAFT (N/S)	1
(E)	4	51070000-A	PIN - DRIVLOC (SHEARROFF) TYPE** 0.094-DIA.X 0.625-LG.	2
	3	63898001-A	SLEEVE (SHAFT)	1
	2	63795000	SCREW-CAP (#300-SER. S/S) #10-32 X 0.375-LG. SOC.HD.	2
	1	23482000-A	CAP - COVER	1

E	(2) PT #23520000 REPL. #23512000	LG	9205
(1) PT #51070000 REPL. #11294000		LG	04
D	(2) PT #17370001 REPL. #17358001	LG	9203
(1) PT #17370001 REPL. #17351001		LG	04
C	#61270000 REPL. #63690000	LG	9006
		LG	04
B	PT#23565 REPL. #22758	MDM	8713
	MOLED PLUS REPL. AMP-ENGL PLUS		04
A	(2) PT #61270000 REPL. #612710	LG	8512
(1) PT #63898001 REPL. #63765		LG	04
	RELEASED TO PROD.		8210
			06

REV.	DATE	BY	CHK'D BY
MATERIAL:			
F P/N 65051001 REP. 61087001 TAB			

**ELKHART BRASS MFG. CO., INC.**  
 ELKHART, INDIANA  
 SELECT-O-MATIC MASTER STREAM NOZZLE  
 ELECTRICALLY OPERATED  
 DESIGNED BY GLOTZBACK  
 SCALE FULL DATE 10-29-84  
 DRAWN BY Rm  
 CHECKED BY J. J. J.  
 3 PLACE DEC. ± 0.010  
 4 PLACE DEC. ± 0.005  
 ANGLES ± 0° 30' 00"  
 CADAM™ REMOVE ALL BURRS AND SHARP CORNERS UNLESS OTHERWISE SPECIFIED DO NOT SCALE PRINT  
 SM-100-E C

# SM-100E

(Old Style - Pre '98)

October, 1998

PART NO.	QUANTITY PER UNIT	DESCRIPTION
23482	1	Cover Cap
64075	2	Cap Screw
63898	1	Shaft Sleeve
51070	2	Drivloc Pin
17358	1	Shaft Bracket O/S (pre '92)
17370	1	Shaft Bracket N/S
61270	1	Set Screw
16664	1	Thread Bushing
51259	1	Roll Pin
61283	1	Shaft Screw
23512	1	Rubber Shaft Cover O/S (Pre '92)
23520	1	Rubber Shaft Cover N/S
17357	1	Motor Bracket O/S (Pre '92)
17710	1	Motor Bracket N/S
46036	1	Electric Motor, 12 VDC
63796	4	Cap Screw
33644	1	Hand Grip
57456	1	"O"-Ring
57414	1	"O"-Ring
80843	1	Stem
17121	1	Nozzle Body Tip
66349	1	Nozzle Tip
61774	1	Coil Spring
65051	1	Cable Screw
33710	1	Stem Guide
17118	1	Nozzle Body
63895	1	Sleeve
71111	1	Reinforcing Washer
63409	1	Stem Base (Web)
57308	1	"O"-Ring
47474	1	Jam Nut (.500-20)
52151	1	Indicator Label
63797	1	Cap Screw
23565	1	Cushioned Loop Clamp

## 2.5" SWIVEL BASE

10610	1	2.5" B/G Base Adapter
63069	1	2.5" R/L Swivel
63674	1	Set Screw
15018	52	.187" Diameter S/S Ball
33083	1	Rubber Gasket, 2.5"

## 3.5" SWIVEL BASE

10611	1	3.5" B/G Base Adapter
63018	1	3.5" R/L Swivel
63675	1	Set Screw
15018	71	.187" Diameter S/S Ball
33186	1	Rubber Gasket, 3.5"

NOZZLE FUNCTION	HYD. PORT	
	PR	TK
FOG	3B	3A
STRT	3A	3B

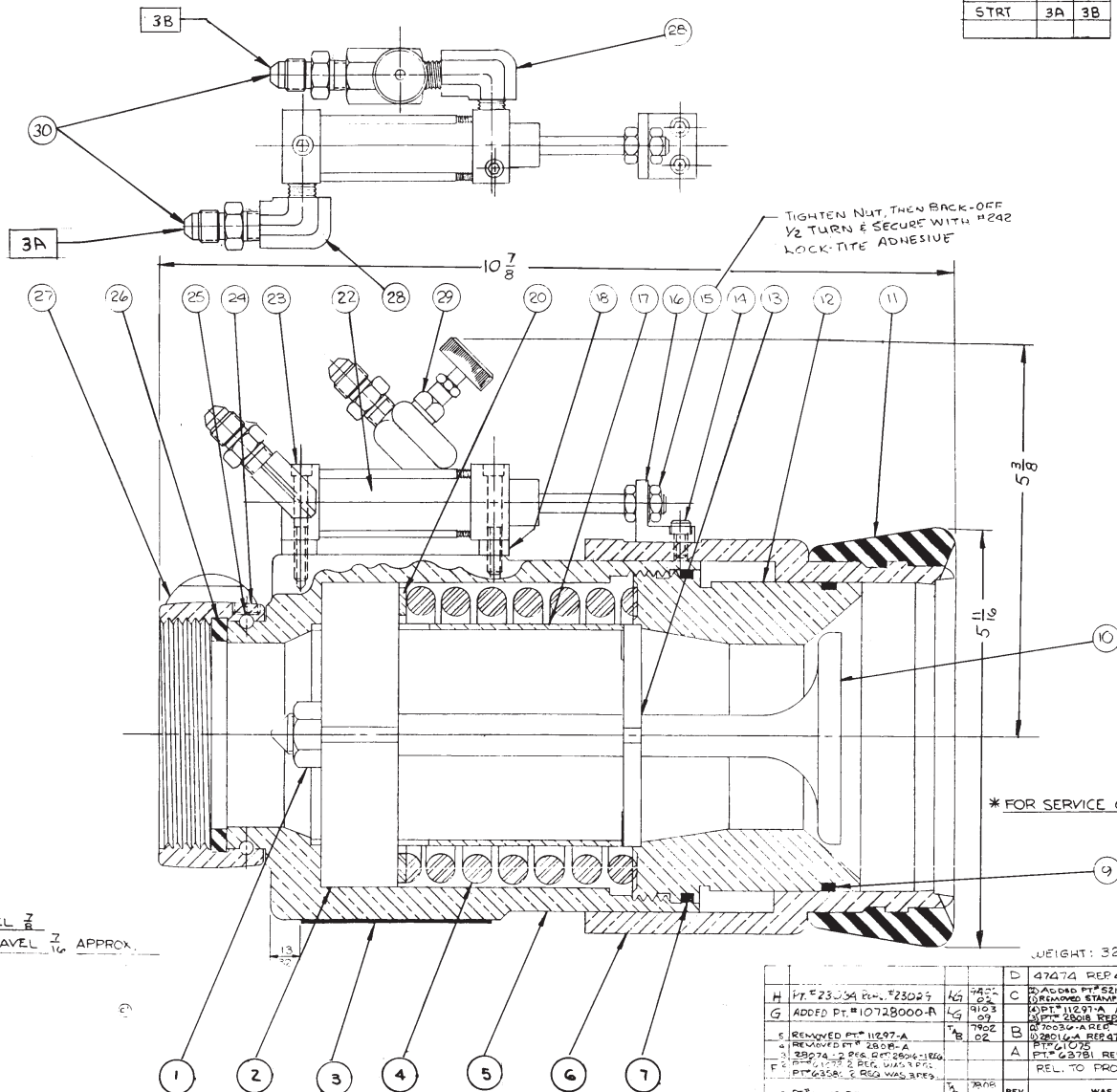

TIP TRAVEL  $\frac{7}{16}$   
STEM TRAVEL  $\frac{7}{16}$  APPROX.

WEIGHT: 32 1/2 LBS.

REV.	DATE	BY	WAS	REL. TO PROD.	MATERIAL
D	47474	REP 47540			
H	PT # 23 USA	REV. # 23023			
G	ADDED PT # 10728000-A				
F	REMOVED PT # 11297-A				
E	REMOVED PT # 2807-A				
D	REMOVED PT # 2807-A				
C	REMOVED PT # 2807-A				
B	REMOVED PT # 2807-A				
A	REMOVED PT # 2807-A				

NO.	PART NO.	PART NAME	REQ.
31			
30	10728000	ADAPTER - BRASS 1/8" N.P.T. x 3/4" 20 U.I.C. 37°	2
29	70036-A	VALVE (METERING) BRASS DELTA CONTROL NFM-10BK 1/2" N.P.T.	1
28	28074-A	ELBOW - 90° BRASS 1/8" N.S.T. MA. x 1/8" N.P.T. FEM	2
27	62919-A 6731-F	SWIVEL - 0° 5/8" 3 1/2" 2.5 N.S.T. 3125 O.D.M.	1
26	33083 PG 124	GASKET - RUBBER 3.187 - O.D. x 2.5621 D.X. 1.87	1
25	23002-A	CHAIN - 5/16" 11.625 LG.	1
24	6222-A PS 137	SCREW - SET (SLOTTED) .375 - 24 x 1.87 (BRASS)	1
23	61073	SCREW - CAP (STAINL. STL) * B - 32 x 1.25 SLT. FILLISTER HD	2
22	23034-A	CYLINDER - POWER (HYD.)	1
21			
20	71111-A	WASHER REINF.	1
19			
18	63580-A	SPACER S/S	2
17	61633	SLEEVE	1
16	16514-A	BRACKET - (ANGLE)	1
15	47544	NUT - JAM 1/4-28	2
14	63781	SCREW - CAP * B - 32 x .375 SOC. HD.	2
13	33710-A	GUIDE - STEM	1
12	15929-B	BODY (TIP) NOZZLE	1
11	33635-A	GRIP - HAND	1
10	62023-B	STEM - NOZZLE	1
9	57385-A	RING - C (TEFLON) 4.000 - I.D. x 4.250 O.D. x .125	1
8			
7	57308 5083-B	RING - O. 4.250 - I.D. x 4.500 - O.D. x .125	1
6	66293-C	TIP - NOZZLE	1
5	15928-C	BODY - (BASE NOZZLE)	1
4	61774-A	SPRING - COIL	1
3	52142-A	PLATE - INDICATOR	1
2	6337B	STEM - BASE	1
1	47474	NUT JAM 1/2-20 (NYLOCK)	1

**ELKHART BRASS MFG. CO., INC.**  
 ELKHART, INDIANA  
 SELECT-O-MATIC NOZZLE (BRASS)  
 1000 G.P.M. @ 100 P.S.I.  
 DATE 2-4-76  
 SCALE 1" = 1"

SM-100 HBP  
 REMOVE ALL BURRS AND SHARP CORNERS  
 UNLESS OTHERWISE SPECIFIED  
 DO NOT SCALE DIMS

# SM-100HBP

April, 1996

<b>PART NO.</b>	<b>QUANTITY PER UNIT</b>	<b>DESCRIPTION</b>
47474	1	Jam Nut (.500-20)
63371	1	Stem Base
52142	1	Indicator Plate
61774	1	Coil Spring
15928	1	Nozzle Body
66293	1	Nozzle Tip
57308	1	"O"-Ring
57385	1	"O"-Ring
62023	1	Stem
33635	1	Hand Grip
15929	1	Nozzle Body Tip
33710	1	Stem Guide
63781	2	Cap Screw (#8-32 X .375" Lg)
47544	2	Jam Nut (.250-28)
16514	1	Angle Bracket
61633	1	Sleeve
63580	2	Spacer
71111	1	Reinforcing Washer
23029	1	Hydraulic Cylinder, O/S (pre '94)
23034	1	Hydraulic Cylinder, N/S
61073	2	Cap Screw (#8-32 X 1.250" Lg)
61222	1	Set Screw
15016	52	.187" Diameter Brass Ball
33083	1	Rubber Gasket, 2.5"
62919	1	2.5" R/L Swivel
28074	2	Elbow (90°) (.125 NPT Fe X 1.25 NPT Ma)
70036	1	Metering Valve
10728	2	Adapter (.125 NPT X .437-20 JIC 37° Ma)