

WEIGHT: 10.25#

SEE DRAWING	9	81118001-B	STEM SUB-ASS'Y	I
CAST BRASS ASTM #B 584 CA #84400	8	16972001-C	BODY-VALVE (NHT M)	I
CAST BRASS ASTM #B 584 CA #84400	7	17522001-B	BONNET-VALVE	I
TO U.L. STANDARD #668	6	57299000	RING-O AS-568-116 0.737-ID X .103M	I
1.375 HEX BRASS NAP ASTM # B 16	5	47579000-A	NUT-PACKING (2.5)	I
PURCHASED ASTM #A 108	4	51073000-A	PIN-DRIVE ZINC PLATED 0.250 DIA X 1.250 LG(TYPE "E")	I
DIE CAST ALUMINUM ASTM #B-179-65-C	3	36320000-B	HANDLE-WHEEL	I
PURCHASED ASTM #A 240	2	71080000-A	WASHER-HANDLE	I
PURCHASED ASTM #A 240	1	61211000	SCREW-SELF TAPPING (S/S) #10-24 X .625-LG. OVAL HD	I
	NO.	PART NO.	PART NAME	REQ.
 ELKHART BRASS MFG. CO., INC. ELKHART, INDIANA				
ELKHART 2.5" ANGLE VALVE (300#) 2.5 NPT F X 2.5 NHT M				
REPLACES DWG. UNLESS OTHERWISE SPECIFIED	REV.	WKS	BY	DATE
MATERIAL:		SCALE	DATE	DATE
		TAB	FULL	7/26/94
		DWG. NO.	CAD. NO.	DWG. SIZE
			U-25 (2.5)	C
		SIGNATURE/TOLERANCE 3 PLACE DEC. ± 0.010 4 PLACE DEC. ± 0.005 ANGLES ± 0.30 07		
CADAM™ REMOVE ALL BURS AND SHARP CORNERS UNLESS OTHERWISE SPECIFIED DO NOT SCALE PRINT				

U-20 & U-25 (2.5")

April, 1996

PART NO.	QUANTITY PER UNIT	DESCRIPTION
61211	1	Self-Tapping Screw
71080	1	Handle Washer
36320	1	Handwheel
51073	1	Drive Pin
47568	1	Packing Nut O/S (Pre '96)
47579	1	Packing Nut N/S
45769	1	Packing Nut (For N.Y. Only)
57299	1	O-Ring
16454	1	Bonnet O/S (Pre '79)
16925	1	Bonnet O/S (Pre '96)
17522	1	Bonnet N/S
16285	1	U-20 Body O/S (Pre '96) (Double Female)
16971	1	U-20 Body N/S
16286	1	U-25 Body, 2.5", O/S (Pre '96) (Female X Male)
16972	1	U-25 Body, 2.5", N/S
80045	1	Stem Assembly O/S (Pre '79)
80527	1	Stem Assembly O/S (Pre '96)
81118	1	Stem Assembly N/S
80045 O/S STEM ASSEMBLY (Pre '79)		
62649	1	Stem
44151	1	Lock Nut
36431	1	Disc Holder
33065	1	Rubber Disc (Seat)
71050	1	Washer
47540	1	Jam Nut
61277	1	Set Screw
80527 O/S STEM ASSEMBLY (Pre '96)		
62666	1	Stem
44151	1	Lock Nut
36431	1	Disc Holder
33065	1	Rubber Disc (Seat)
71050	1	Washer
47540	1	Jam Nut
61269	1	Set Screw
81118 N/S STEM ASSEMBLY		
36964	1	Stem
47435	1	Stem Nut
36434	1	Disc Holder
33254	1	Rubber Disc (Seat)
71050	1	Disc Washer
47540	1	Jam Nut

Drawing on back 

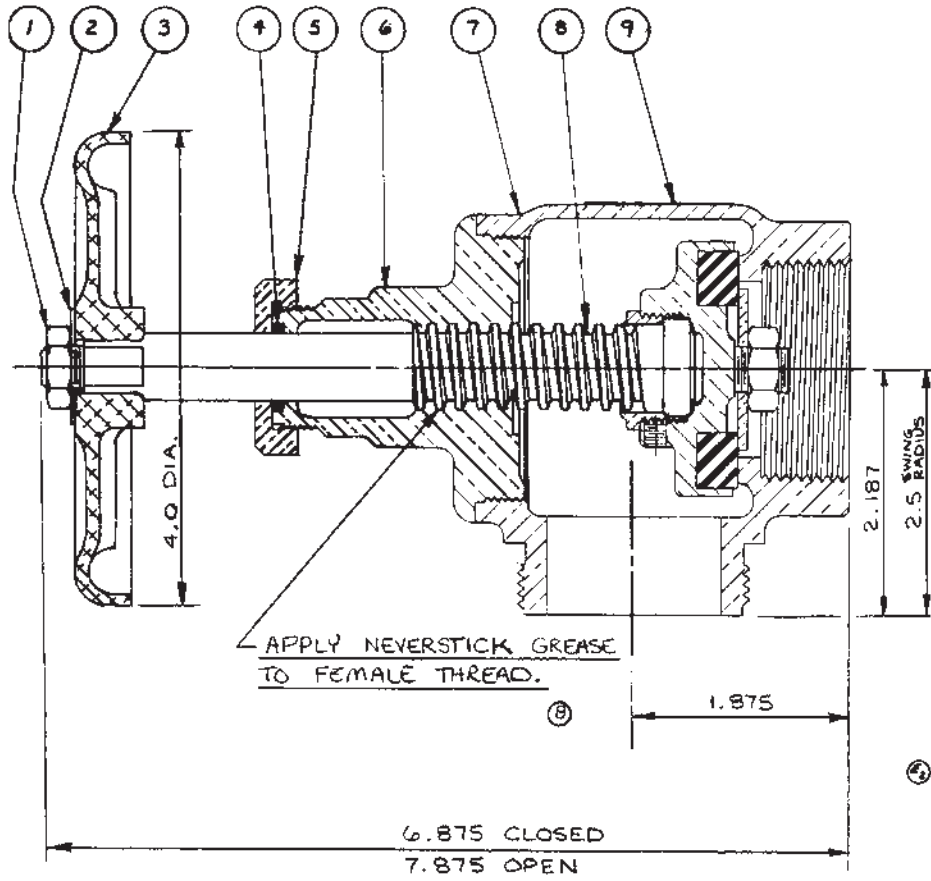

⑨	44231-A	LABEL - UL.	1
⑧	80530-A	STEM ASS'Y	1
7	16265-B 6423-A	1/2 FEMALE x 1/2 MALE BODY	1
6	16924-A	BONNET	1
5	47575-A	PACKING NUT	1
4	5742B	O-RING (.362 x .750 x .093)	1
3	36661-A	4" HANDWHEEL	1
2	71079-A	WASHER - FLAT	1
1	97542-A	GRIPCO - TOPLOCK	1
	PN-119	.375-24 BR JAM NUT	1

⑤	SEE DRWG.		
④	CAST BRASS ASTM # B-30-836		
③	CAST BRASS ASTM # B-30-844		
②	1/2 HEX YELLOW BR. BAR ASTM # B16		
①	TO UL. STD. #668		
⑥	DIE CAST ALUM ASTM # B-179-G5-C		
⑦	20GA (.032) BRASS STRIP ASTM # B 19		
⑧	PURCHASED ASTM # B16		

E	47575 RER OBS 47567		
D	36661 RER 71214		
C	71079 RER 71080		
B	REPLACE BY 97542 PT. #44200 REMOVED &	AG	7412 12
A	PT. #44200 ADDED	PLP	7304 06

F	PT. #5742B RER PT. #57345	R _M	8005 09
E	REMOVED STAMP NOTE ADDED PT. #44231-A	T _A B	1901 04
D	80530 RER OBS 80044		
C	16924 RER OBS 16441		

NO.	DRWG NO	PART NO	PART NAME	REQ

ELKHART BRASS MFG. CO., INC.		ELKHART, INDIANA	
1/2 MALE X FEMALE ANGLE VALVE UNDERWRITERS APPROVED			
DRN BY	DATE	PART NO	
HARTLER	12-23-63		
CHKD BY	SCALE		
	FULL		
APPD BY			U-25-1.5

FRACTIONS	±	.010
DECIMALS	±	.006
ANGLES	±	9°

REMOVE ALL BURRS AND SHARP CORNERS UNLESS OTHERWISE SPECIFIED DO NOT SCALE PRINT	
--	--

U-20 & U-25 (1.5")

April, 1996

PART NO.	QUANTITY PER UNIT	DESCRIPTION
61211	1	Self-Tapping Screw O/S (Pre '79)
71080	1	Handle Washer O/S (Pre '79)
71214	1	Handwheel, O/S (Pre '79)
47542	1	Lock Nut N/S
71074	1	Handle Washer N/S
36661	1	Handwheel N/S
57345	1	"O"-Ring O/S (Pre '79)
57428	1	"O"-Ring N/S
47567	1	Packing Nut O/S (Pre '79)
47575	1	Packing Nut N/S
16441	1	Bonnet O/S (Pre '79)
16924	1	Bonnet N/S
16264	1	U-20 Body, 1.5" (Double Female)
16265	1	U-25 Body, 1.5" (Female X Male)
80044	1	Stem Assembly O/S (Pre '79)
80530	1	Stem Assembly N/S

80044 O/S STEM ASSEMBLY (Pre '79)

62641	1	Stem
44150	1	Lock Nut
36430	1	Disc Holder
33063	1	Rubber Disc (Seat)
71002	1	Washer
47542	1	Jam Nut
61277	1	Set Screw

80530 N/S STEM ASSEMBLY

62667	1	Stem
44153	1	Lock Nut
36430	1	Disc Holder
33063	1	Rubber Disc (Seat)
71002	1	Washer
47542	1	Jam Nut
61269	1	Set Screw

Drawing on back 