

GEARCASE POSITION
(VALVE SHOWN CLOSED)

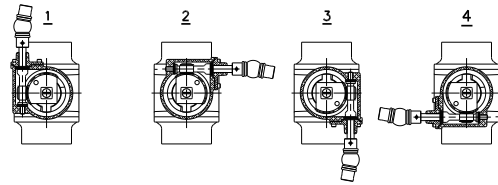

(P/N 99362501) #92 GEAR ACTUATOR
SAME AS #90 GEAR ACTUATOR EXCEPT
W/INDICATOR LIGHTS

49	61177000	SCREW-MACH (TYPE 3502 SS) #4-40 X 0.187-LG PAN HD	2
48	81022000	INDICATOR LIGHT MODULE	1
35	46051000	MAGNET	1
13	36782000	HARNESS-CONTROL	1
NOT SHOWN	36781000	HARNESS-POWER	1
NOT SHOWN	16805000	BAG-ZIP LOC 9.5"X 13"	1

**P/N (81170001) INDICATOR LIGHTS
OPTIONAL**

47	41042000	U-JOINT	1
46	51236000	PIN-ROLL 79-040-187-0812	3
45	16681000	BRUSHING-TUBERON NYLITER TYPE 5, #BL6-F	2
44	47482000	NUT-JAM	1
43	11679004	ADAPTER-PANEL	1
42	64043001	SHAFT-HANDWHEEL	1
41	81020001	5" HANDWHEEL SUB-ASS'Y (ALUM)	1

P/N (81031001) REMOTE OPERATOR

40	23488000	CAP-PLUG	1
39	15034000	BALL-5/32 DIA. (BUNA-N)	2
38	51122000	PIN - SOLID 0.3125 X 0.375-LG	2
37	63795000	SCREW-SOC HD (#300 S/S)	4
36	33784001	GEAR-SEGMENTAL	1
34	57380000	O-RING (AS 568-008) 1.76 ID X 0.070 C/S	1
33	17702000	BEARING-THRUST (5/16)	1
32	71516000	WASHER-THRUST (5/16)	2
31	63941001	SHAFT - WORM S/S	1
30	15698000	BEARING-THRUST (1/2)	1
29	71511000	WASHER-THRUST (1/2)	2
28	33804000	GASKET-MOTOR MOUNTING ADAPTER	1
27	57298000	O-RING (AS 568-012) 0.364 ID X 0.070 C/S	1
26	10455001	ADAPTER - FLANGED	1
25	51236000	PIN-ROLL 79-040-187-0812	1
24	41042000	U-JOINT	1
23	57339000	O-RING (AS 568-146) 2.612 ID X 0.103 C/S	2
22	58892001	RETAINER SEAT (1.5)	2
21	57318000	O-RING (AS 568-142) 2.362 ID X 0.103 C/S	2
20	57309000	O-RING (AS 568-227) 1.734 ID X 0.132 C/S	2
19	61173000	SCREW-MACH (TYPE 3502 SS) #4-40 X 0.187-LG PAN HD	8
18	65111000	SCREW-MACH SS #10-24 X 0.875-LG HEX HD	4
17	51815000	PLATE-STOP	1
16	23581001	CASE-GEAR (SMALL)	1
15	33048000	GASKET-COVER	1
14	23519001	COVER-GEAR CASE (SMALL)	1
13	36782000	HARNESS-CONTROL	1
12	64065000	SCREW-CAP (STNLS STL) #8-32 X 0.375-LG, SOC HD	3
11	57321000	O-RING (AS 568-014) 0.489 ID X 0.070 C/S	1
10	63771001	SHAFT-ACTUATOR (UPPER)	1
9	71514001	WASHER-THRUST	1
8	51235000	PIN-ROLL 79-040-187-0875	1
7	57474000	O-RING (AS 568-038) 2.114 ID X 0.070 C/S	1
6	63775001	SHAFT-ACTUATOR (LOWER)	1
5	57396000	O-RING (AS 568-124) 1.237 ID X 0.103 C/S	1
4	71188000	WASHER-TEFLON	1
3	17311000	BALL-VALVE (1.5) ACETAL	1
2	63855000	SEAT-VALVE (1.5) U.H.W.P.E.	2
1	16997001	BODY-VALVE (1.5)	1

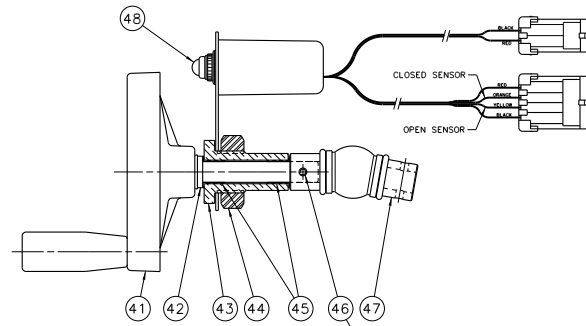

DO NOT INSERT ROLL PIN.
PLACE INTO BAG AND WIRE
TIE TO HOLD PARTS TOGETHER

(99362001) #90 GEAR ACTUATOR

REMOTE OPERATOR
SCALE: 1/2

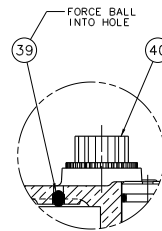

DETAIL A
SCALE: 1 1/2 X SIZE

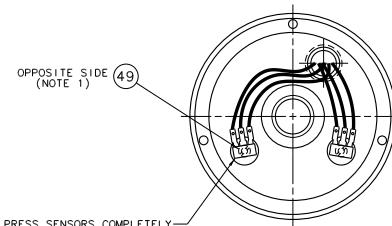

**BOTTOM VIEW OF
GEAR CASE COVER**

CAUTION: PRESS SENSORS COMPLETELY
IN BY HAND BEFORE TORQUING SCREW
(TORQUE NOT EXCEED 20 INCH-OUNCE)

- 1) SECURE THREADS WITH "LOCTITE" ADHESIVE #242 (BLUE)
- 2) APPLY GENERAL PURPOSE PETROLEUM BASE GREASE.
- 3) FILE THREADS FLAT WITH GEAR SEGMENT SURFACE.
- 4) SECURE WITH "LOCTITE" RETAINING COMPOUND #601 (GREEN) IN ADAPTER ONLY.

NO.	PART NO.	PART NAME	REQ.
ELKHART BRASS MFG. CO., INC. ELKHART, INDIANA			
VALVE - (1.5) FIRE APPARATUS (GEAR ACTUATOR)			
A 33804000 REPL. 33801000		TAB 9707	REV 009
RELEASED TO PROD. RDM		SCALE FULL	DATE 8/2/96
REV.	MAG	BY	C.I.M.
DESIGNED BY	RDM	CAT. NO.	2915-G
MATERIAL:		DRWG. SIZE	D
REMARKS: DIMENSIONS IN PARENTHESIS ARE SHOWN FOR REFERENCE ONLY.		CADAM	

DRAWING (2915/500) 2915-G REV A

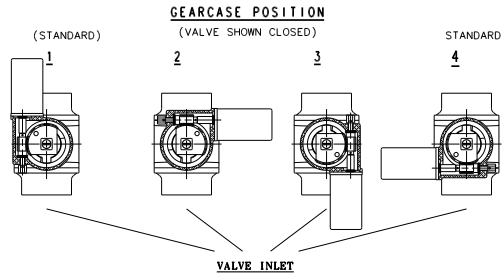
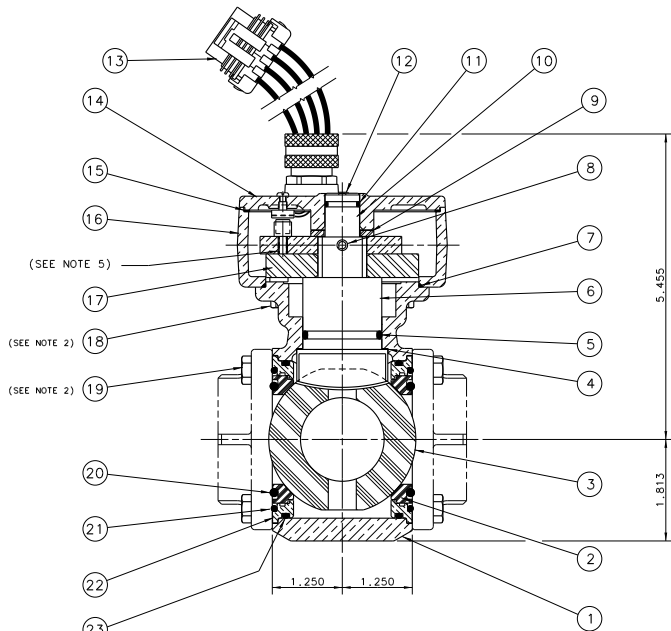
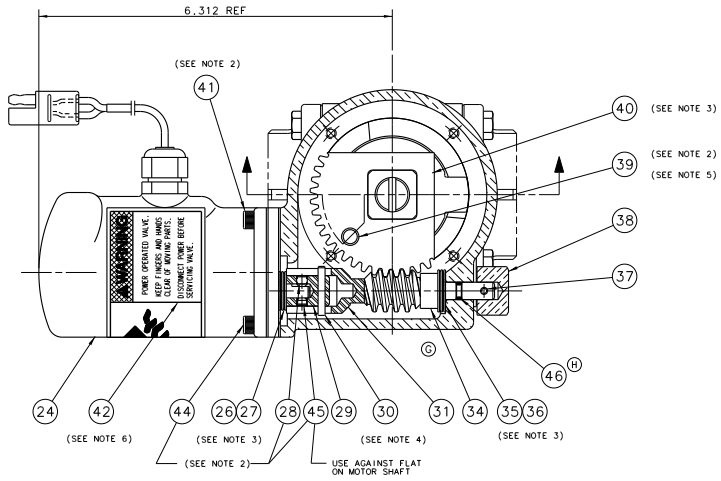

CAUTION: PRESS SENSORS COMPLETELY IN BY HAND BEFORE TORQUING SCREW (TORQUE NOT EXCEED 20 INCH-OUNCE)

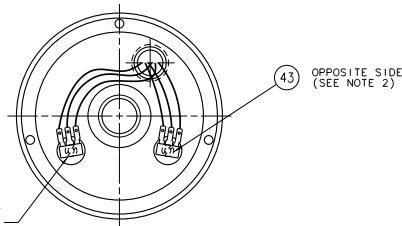

COVER DETAIL

- 6) BEFORE APPLYING DECAL SURFACE MUST BE CLEANED W/RUBBING ALCOHOL OR OTHER NON RESIDUE CLEANER. ALSO, PREMASK SHOULD NOT BE REMOVED FROM DECAL.
- 5) FILE THREADS FLAT WITH GEAR SEGMENT SURFACE.
- 4) PIN MUST BE IN CENTER OF SHAFT COUPLING.
- 3) APPLY GENERAL PURPOSE PETROLEUM BASE GREASE.
- 2) SECURE THREADS WITH *LOCTITE* ADHESIVE #242 (BLUE)

(E)	(B)	81205000	INFORMATION AND PARTS PACKET	1
NOT SHOWN		81052000	SWITCH/INDICATOR MODULE	1
NOT SHOWN		81196000	ELECTRIC VALVE CONTROL MODULE	1

ELECTRIC CONTROL MODULE

(H)	46	57380000	O-RING (AS 568-008)	1
(L)	45	63699000	SCREW-SET SS (CUP POINT)	1
(L)	44	64072000	#10-32 x 0.187-LG. SOC HEX	1
(L)	43	61177000	SCREW-CAP (#300 SERIES S-3)	3
(C)	42	25025000	SCREW-PAN MACH. (#10-32 x 0.150-LG. SOC HEX)	2
(L)	41	61046000	NUT-VALVE (3/4 HEX)	1
(L)	40	33784001	DECAL-WARNING	1
(L)	39	46051000	SCREW-CAP (#300 SERIES S-3)	1
(L)	38	47652001	GEAR-SEGMENTAL	1
(A)	37	51248000	WASHER	1
(A)	36	17702000	NUT-VALVE (3/4 HEX)	1
(A)	35	71516000	PIN-ROLL 79-228-125-0825	1
(A)	34	63601001	BEARING-THRUST (5/16)	1
(A)	33		WASHER-THRUST (5/16)	2
(A)	32		SPACER	1
(C)	31	63935001	(#99357001) #91 ELECTRIC ACTUATOR	
(C)	30	51071000	SHAFT-WORM	1
(L)	29	20985001	PIN-DRVLOC	1
(L)	28	65201000	COUPLING-FEMALE SHAFT	1
(L)	27	17701000	SCREW-SET SS (CUP POINT)	1
(L)	26	71515000	#10-32 x 0.150-LG. SOC HEX	1
(L)	25		BEARING-THRUST (1/4)	2
(L)	24	81119001	WASHER-THRUST (1/4)	2
(L)	23	57339000	ASSEMBLY GEAR MOTOR, 12-VDC (65.5:1 GEAR RATIO)	1
(C)	22	58892000	RING-O (AS 568-146)	2
(C)	21	57318000	SEAT RETAINER (1.5)	2
(C)	20	57309000	RING-O (AS 568-142)	2
(A)	19	61144000	2.362 ID X 0.103 C/S	2
(A)	18	65111000	RING-O (AS 568-224)	2
(A)	17	51815000	1.734 ID X 0.358 C/S	4
(A)	16	23581001	SCREW-MACH. ZINC PLT #10-24 X 0.700 LG HK HD	8
(A)	15	33048000	SCREW-MACH. SS #10-24 X 0.700 LG HK HD	4
(A)	14	23519001	PLATE-STOP	1
(A)	13	36782000	CASE-GEAR (SMALL) N/S	1
(A)	12	64065000	GASKET-COVER	1
(A)	11	57321000	COVER-GEAR CASE (SMALL)	1
(A)	10	63771001	HARNESSE-CONTROL	1
(A)	9	71514001	SCREW-CAP (STAIN SS) #6-32 X 0.375-LG. SOC HD	3
(A)	8	51235000	O-RING (AS 568-038)	1
(A)	7	57474000	O-RING (AS 568-038)	1
(A)	6	63775001	O-RING (AS 568-038)	1
(A)	5	57396000	O-RING (AS 568-124)	1
(A)	4	71188000	2.217 ID X 0.103 C/S	1
(A)	3	17311000	WASHER-TEFLON	1
(A)	2	63855000	BALL-VALVE (1.5) ACETAL	1
(A)	1	16997001	BODY-VALVE (1.5)	1

NO.	PART NO.	PART NAME	REV.
ELKHART BRASS MFG. CO., INC. ELKHART, INDIANA			
VALVE - FIRE APPARATUS WITH 1.5 BALL			
REV.	DATE	BY	CHKD BY
1	1992-02-14	S. STUMD	S. STUMD
2	1992-02-14	S. STUMD	S. STUMD
3	1992-02-14	S. STUMD	S. STUMD
4	1992-02-14	S. STUMD	S. STUMD
5	1992-02-14	S. STUMD	S. STUMD
6	1992-02-14	S. STUMD	S. STUMD
7	1992-02-14	S. STUMD	S. STUMD
8	1992-02-14	S. STUMD	S. STUMD
9	1992-02-14	S. STUMD	S. STUMD
10	1992-02-14	S. STUMD	S. STUMD
11	1992-02-14	S. STUMD	S. STUMD
12	1992-02-14	S. STUMD	S. STUMD
13	1992-02-14	S. STUMD	S. STUMD
14	1992-02-14	S. STUMD	S. STUMD
15	1992-02-14	S. STUMD	S. STUMD
16	1992-02-14	S. STUMD	S. STUMD
17	1992-02-14	S. STUMD	S. STUMD
18	1992-02-14	S. STUMD	S. STUMD
19	1992-02-14	S. STUMD	S. STUMD
20	1992-02-14	S. STUMD	S. STUMD
21	1992-02-14	S. STUMD	S. STUMD
22	1992-02-14	S. STUMD	S. STUMD
23	1992-02-14	S. STUMD	S. STUMD
24	1992-02-14	S. STUMD	S. STUMD
25	1992-02-14	S. STUMD	S. STUMD
26	1992-02-14	S. STUMD	S. STUMD
27	1992-02-14	S. STUMD	S. STUMD
28	1992-02-14	S. STUMD	S. STUMD
29	1992-02-14	S. STUMD	S. STUMD
30	1992-02-14	S. STUMD	S. STUMD
31	1992-02-14	S. STUMD	S. STUMD
32	1992-02-14	S. STUMD	S. STUMD
33	1992-02-14	S. STUMD	S. STUMD
34	1992-02-14	S. STUMD	S. STUMD
35	1992-02-14	S. STUMD	S. STUMD
36	1992-02-14	S. STUMD	S. STUMD
37	1992-02-14	S. STUMD	S. STUMD
38	1992-02-14	S. STUMD	S. STUMD
39	1992-02-14	S. STUMD	S. STUMD
40	1992-02-14	S. STUMD	S. STUMD
41	1992-02-14	S. STUMD	S. STUMD
42	1992-02-14	S. STUMD	S. STUMD
43	1992-02-14	S. STUMD	S. STUMD
44	1992-02-14	S. STUMD	S. STUMD
45	1992-02-14	S. STUMD	S. STUMD
46	1992-02-14	S. STUMD	S. STUMD

PART NUMBER (029) 5100 2915-E (REV. 1)

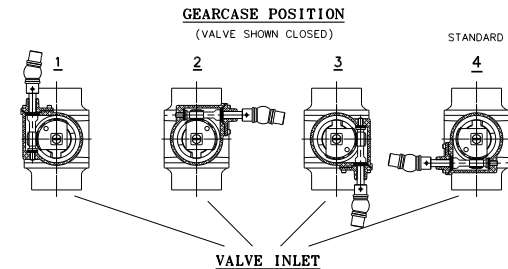
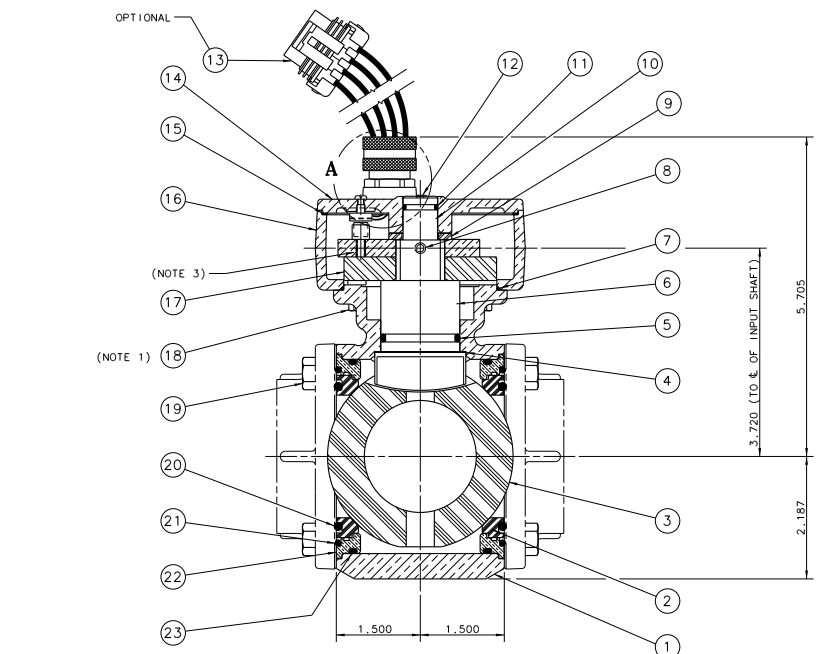
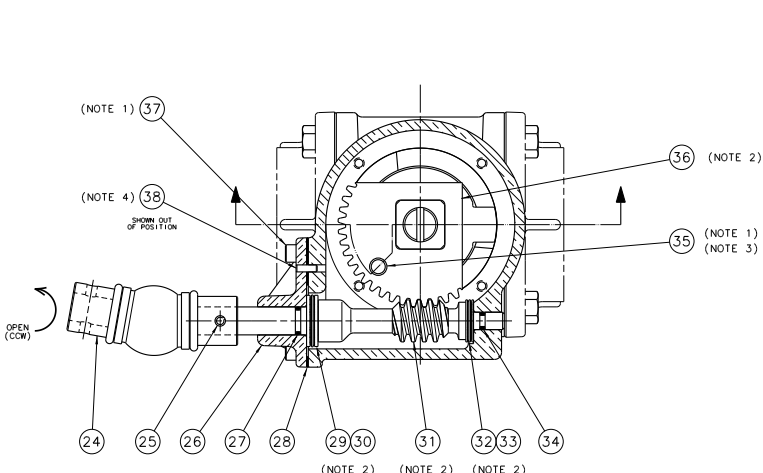

(P/N 99362501) #92 GEAR ACTUATOR
SAME AS #90 GEAR ACTUATOR EXCEPT
W/INDICATOR LIGHTS

49	61177000	SCREW-MACH (#302 S/S) #4-40 X 0.187-1/2 LG. PAN HD	2
48	81022000	INDIATOR LIGHT MODULE	1
35	46051000	MAGNET # 0.31 X 0.67 LG #8-32 THD.	1
13	36782000	HARNES-CONTROL	1
NOT SHOWN	36781000	HARNES-POWER	1
NOT SHOWN	16805000	BAG-ZIP LOC 9.5" X 13"	1

(P/N 81170001) INDICATOR LIGHTS
OPTIONAL

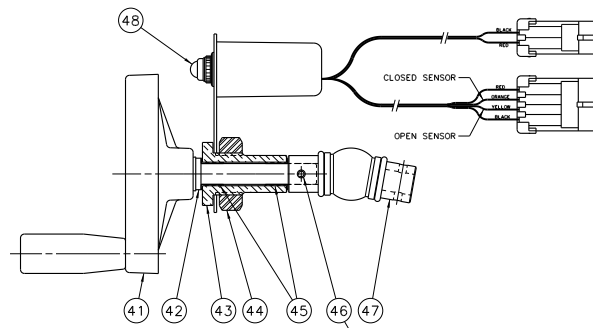

(P/N 99362001) #90 GEAR ACTUATOR

47	41042000	U-JOINT	1
46	51236000	PIN-ROLL 79-040-187-0812	3
45	16681000	BUSHING-TIMONOR NYLONER TYPE 5, #8L6-F	2
44	47482000	NUT-JAM	1
43	11679004	ADAPTER-PANEL	1
42	64043001	SHAFT-HANDWHEEL	1
41	81020001	5" DIA HANDWHEEL SUB-ASSY VALUM	1

(P/N 81031001) REMOTE OPERATOR

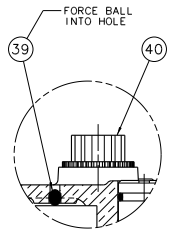

DETAIL A
SCALE: 1 1/2 X SIZE

DO NOT INSERT ROLL PIN. PLACE INTO BAG AND WIRE TIE TO HOLD PARTS TOGETHER

REMOTE OPERATOR
SCALE: 1/2

CAUTION: PRESS SENSORS COMPLETELY IN BY HAND BEFORE TORQUING SCREW (TORQUE NOT EXCEED 20 INCH-OUNCE)

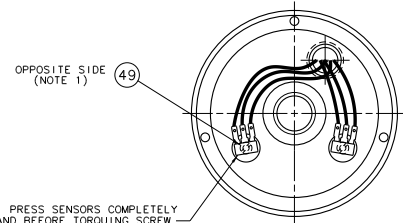

BOTTOM VIEW OF GEAR CASE COVER

- 1) SECURE THREADS WITH "LOCTITE" ADHESIVE #242 (BLUE)
- 2) APPLY GENERAL PURPOSE PETROLEUM BASE GREASE.
- 3) FILE THREADS FLAT WITH GEAR SEGMENT SURFACE.
- 4) SECURE WITH "LOCTITE" RETAINING COMPOUND #601 (GREEN) IN ADAPTER ONLY.

REV.	WAS	BY	E.C.M.	DATE	SCALE	FULL	DATE	BY/15/96	CONG. SIZE
A	33804000	REPL.	33801000	TAB	9/20/96				
RELEASED TO PROD. RDM									
OWN BY R. CANFIELD									
CAT. NO. 2920-G									
MATERIAL: CADAM									

NO.	PART NO.	PART NAME	REQ.
		ELKHART BRASS MFG. CO., INC. ELKHART, INDIAN	
		VALVE (2.0) FIRE APPARATUS (GEAR ACTUATOR)	
		9 PLACES DEC. - 1.000	
		10 PLACES DEC. - 1.000	
		11 PLACES DEC. - 1.000	
		12 PLACES DEC. - 1.000	

PART 02920300 2920-G REV. A

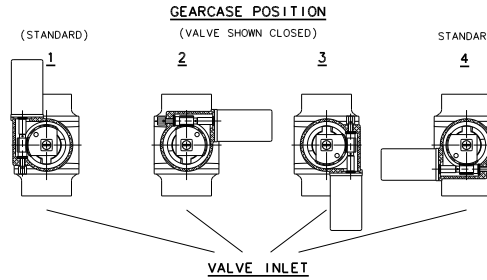
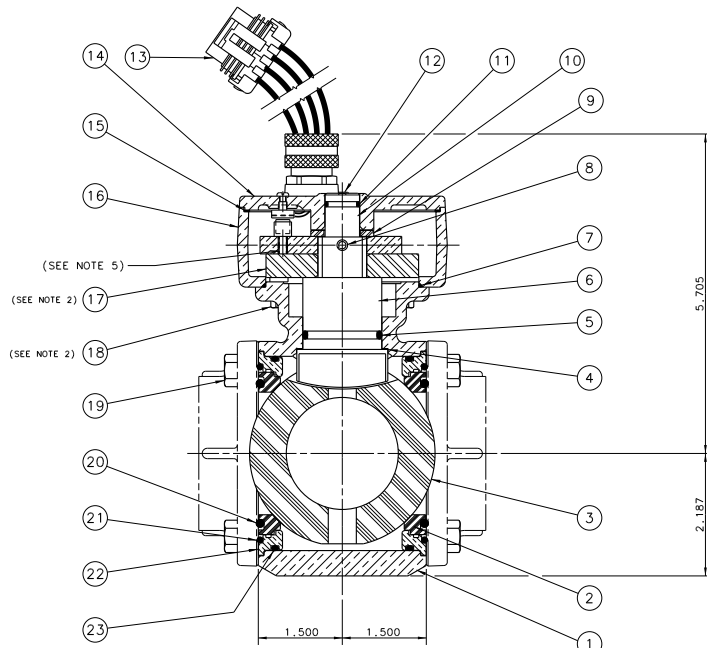
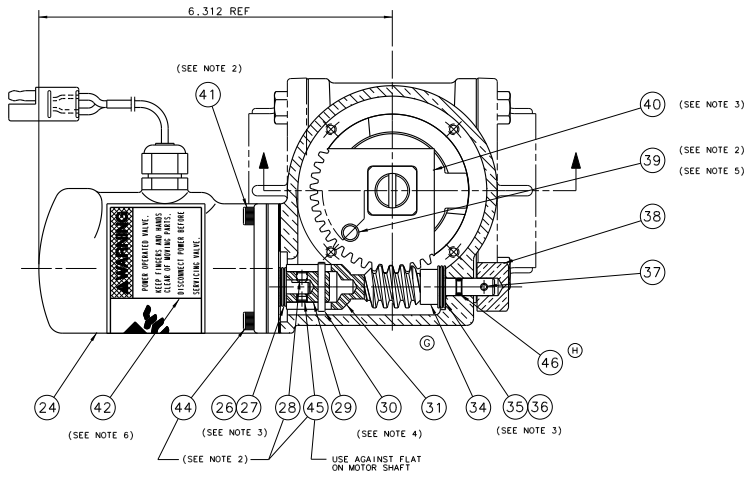

CAUTION: PRESS SENSORS COMPLETELY IN BY HAND BEFORE TORQUING SCREW (TORQUE NOT EXCEED 20 INCH-OUNCE)

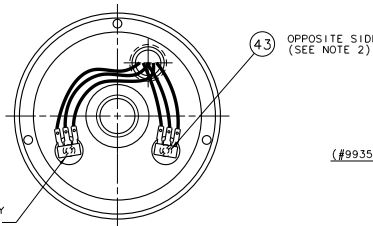

COVER DETAIL

- 6) BEFORE APPLYING DECAL SURFACE MUST BE CLEANED W/RUBBING ALCOHOL OR OTHER NON RESIDUE CLEANER. ALSO, PREMASK SHOULD NOT BE REMOVED FROM DECAL.
- 5) FILE THREADS FLAT WITH GEAR SEGMENT SURFACE.
- 4) PIN MUST BE IN CENTER OF SHAFT COUPLING.
- 3) APPLY GENERAL PURPOSE PETROLEUM BASE GREASE.
- 2) SECURE THREADS WITH "LOCTITE" ADHESIVE #242 (BLUE)

(B)	(B)	81205000	INFORMATION AND PARTS PACKET	1
		81052000	SWITCH/INDICATOR MODULE	1
	(E)	81196000	ELECTRIC VALVE CONTROL MODULE	1

ELECTRIC CONTROL MODULE

24	81147001	ASSEMBLY GEARMOTOR, 12-VDC (19.7:1 GEAR RATIO)	1
Item (02920200) 2920-E VALVE W/FAST MOTOR			

(H)	46	57380000	O-RING (FAS 568-008) 0.376 ID X 0.070 C/S	1
(D)	45	63699000	SCREW-SET 5/8 (TOP POINT) #10-32 X 0.187-LG, 50C HEX HD	1
(D)	44	64072000	SCREW-CAP (#300 SERIES 5/32) #10-32 X 0.350-LG, 50C HD	3
(C)	43	61177000	SCREW-PAN MACH #1-40 X 0.187-LG (TYPE #302 SS)	2
(C)	42	25025000	DECAL-WARNING	1
(C)	41	61046000	SCREW-CAP (#300 SERIES 5/32) #10-32 X 0.250-LG, 50C HD	1
(C)	40	33784001	GEAR-SEGMENTAL	1
(C)	39	46051000	MAGNET # 0.31 X 0.67-LG #8-32 THD	1
(C)	38	47652001	NUT-VALVE (3/4 HEX)	1
(A)	37	51248000	PIN-ROLL 79-040-187-0875	1
(A)	36	17702000	BEARING-THRUST (5/16)	1
(A)	35	71516000	WASHER-THRUST (5/16)	2
(A)	34	63601001	SPACER	1
(C)	33			
(C)	32			
(C)	31	63935001	SHAFT-WORM	1
(C)	30	51071000	PIN-DRVLOC	1
(C)	29	20985001	COUPLING-FEMALE SHAFT	1
(C)	28	65201000	SCREW-SET 5/8 (TOP POINT) #10-32 X 0.125-LG, 50C HEX HD	1
(C)	27	17701000	BEARING-THRUST (1/4)	1
(C)	26	71515000	WASHER-THRUST (1/4)	2
(C)	25			
(C)	24	81119001	ASSEMBLY GEARMOTOR, 12-VDC (65.5:1 GEAR RATIO)	1
(C)	23	57414000	O-RING (FAS 568-152) 3.237 ID X 0.103 C/S	2
(C)	22	58893000	SEAT RETAINER (2.0)	2
(C)	21	57490000	SCREW-SET 5/8 (TOP POINT) #10-32 X 0.125-LG, 50C HEX HD	2
(C)	20	57386000	RING-LS (FAS 568-229) 2.987 ID X 0.103 C/S	2
(C)	19	61059000	RING-LS (FAS 568-151) 2.987 ID X 0.103 C/S	2
(C)	18	65111000	SCREW-MACH 5/16 #10-32 X 0.300-LG, HEX HD	8
(A)	17	51815000	PLATE-STOP	1
(A)	16	23581001	CASE-GEAR (SMALL) N/S	1
(A)	15	33048000	GASKET-COVER	1
(A)	14	23519001	COVER-GEAR CASE (SMALL)	1
(A)	13	36782000	HARNES-SS CONTROL	1
(A)	12	64065000	SCREW-CAP (STML5 STL) #8-32 X 0.376-LG, 50C HD	3
(A)	11	57321000	O-RING (AS 568-038) 2.814 ID X 0.070 C/S	1
(A)	10	63771001	SHAFT-ACTUATOR (UPPER)	1
(A)	9	71514001	WASHER-THRUST	1
(A)	8	51235000	PIN-ROLL 79-040-187-0875	1
(A)	7	57474000	O-RING (AS 568-038) 2.814 ID X 0.070 C/S	1
(A)	6	63775001	SHAFT-ACTUATOR (LOWER)	1
(A)	5	57396000	O-RING (AS 568-124) 2.217 ID X 0.103 C/S	1
(A)	4	71188000	WASHER-TEFLON	1
(A)	3	17312000	BALL-VALVE (2.0) ACETAL	1
(A)	2	63856000	SEAT-VALVE (2.0) U.H.W.P.E.	2
(A)	1	16996001	BODY-VALVE (2.0)	1

(#99357001) #91 ELECTRIC ACTUATOR

NO.	PART NO.	PART NAME	REQ.
 ELKHART BRASS MFG. CO., INC. ELKHART, INDIANA			
VALVE - FIRE APPARATUS WITH 2.0 BALL			
DATE: FEB. 13, 1992			
DESIGNED BY: S. STUMM		DRAWN BY: RDM	
CHECKED BY:		REV. DATE:	
2920-E			
3 PLACES REQ. - 1.000		5 PLACES REQ. - 1.000	
4 PLACES REQ. - 1.000		1 PLACES REQ. - 1.000	
ANGLE: 4 1/2" DIA.			

DRAWN: (02920100) 2920-E (REV. H)

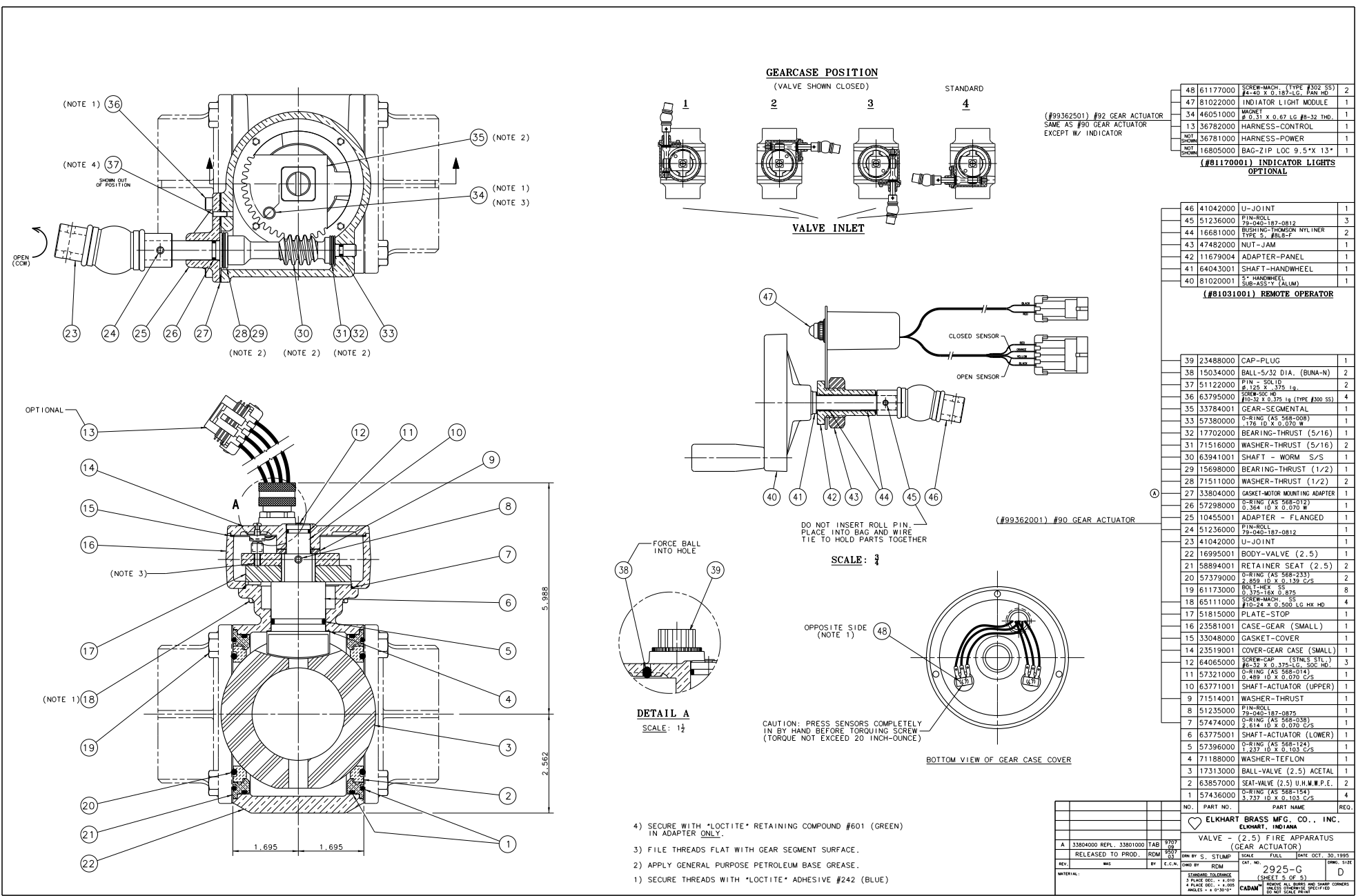

48	61177000	SCREW-MACH (TYPE #302 SS) #4-40 X 0.187-LG. PAN HD	2
47	81022000	INDIATOR LIGHT MODULE	1
34	46051000	MAGNET # 0.31 X 0.67 LG. #8-32 THD.	1
13	36782000	HARNESS-CONTROL	1
NOT SHOWN	36781000	HARNESS-POWER	1
NOT SHOWN	16805000	BAG-ZIP LOC 9.5"X 13"	1

(#99362501) #92 GEAR ACTUATOR SAME AS #90 GEAR ACTUATOR EXCEPT W/ INDICATOR

(#81170001) INDICATOR LIGHTS OPTIONAL

46	41042000	U-JOINT	1
45	51236000	FIN-ROLL 79-040-187-0812	3
44	16681000	BUSHING-TIMONOR NYLONER TYPE 5, #BL6-F	2
43	47482000	NUT-JAM	1
42	11679004	ADAPTER-PANEL	1
41	64043001	SHAFT-HANDWHEEL	1
40	81020001	SUB-ASSY (ALUM)	1

(#81031001) REMOTE OPERATOR

39	23488000	CAP-PLUG	1
38	15034000	BALL-5/32 DIA. (BUNA-N)	2
37	51122000	FIN - SOLID #125 X .375 LG.	2
36	63795000	#10-32 X 0.375 LG. (TYPE #300 SS)	4
35	33784001	GEAR-SEGMENTAL	1
33	57380000	O-RING (AS 568-008) .176 ID X 0.070 W	1
32	17702000	BEARING-THRUST (5/16)	1
31	71516000	WASHER-THRUST (5/16)	2
30	63941001	SHAFT - WORM S/S	1
29	15698000	BEARING-THRUST (1/2)	1
28	71511000	WASHER-THRUST (1/2)	2
27	33804000	GASKET-MOTOR MOUNTING ADAPTER	1
26	57298000	O-RING (AS 568-012) 0.364 ID X 0.070 W	1
25	10455001	ADAPTER - FLANGED	1
24	51236000	FIN-ROLL 79-040-187-0812	1
23	41042000	U-JOINT	1
22	16995001	BODY-VALVE (2.5)	1
21	58894001	RETAINER SEAT (2.5)	2
20	57379000	O-RING (AS 568-233) 2.859 ID X 0.130 C/S	2
19	61173000	BOLT-HEX SS #10-32 X 1.00 LG. HX HD	8
18	65111000	SCREW-MACH SS #10-24 X 1.00 LG. HX HD	4
17	51815000	PLATE-STOP	1
16	23581001	CASE-GEAR (SMALL)	1
15	33048000	GASKET-COVER	1
14	23519001	COVER-GEAR CASE (SMALL)	1
12	64065000	SCREW-CAP (STINLS STL) #8-32 X 0.370-LG. SOC HD	3
11	57321000	O-RING (AS 568-014) 0.489 ID X 0.070 C/S	1
10	63771001	SHAFT-ACTUATOR (UPPER)	1
9	71514001	WASHER-THRUST	1
8	51235000	FIN-ROLL 79-040-187-0875	1
7	57474000	O-RING (AS 568-038) 2.614 ID X 0.070 C/S	1
6	63775001	SHAFT-ACTUATOR (LOWER)	1
5	57396000	O-RING (AS 568-124) 1.237 ID X 0.103 C/S	1
4	71188000	WASHER-TEFLON	1
3	17313000	BALL-VALVE (2.5) ACETAL	1
2	63857000	SEAT-VALVE (2.5) U.H.W.P.E.	2
1	57436000	O-RING (AS 568-154) 3.737 ID X 0.103 C/S	4

NO.	PART NO.	PART NAME	REQ.
ELKHART BRASS MFG. CO., INC.			
ELKHART, INDIANA			
VALVE - (2.5) FIRE APPARATUS (GEAR ACTUATOR)			
OWN BY S. STUMP			
SCALE FULL DATE OCT. 30, 1995			
CAT. NO. 2925-G			
DWG. SIZE D			
STANDARD DIMENSIONS			
3 PLACE DEC. = 1/1000			
4 PLACE DEC. = 1/2500			
ANGLES = 1/32" = 1/16"			
CADAM			

- 1) SECURE THREADS WITH "LOCTITE" ADHESIVE #242 (BLUE)
- 2) APPLY GENERAL PURPOSE PETROLEUM BASE GREASE.
- 3) FILE THREADS FLAT WITH GEAR SEGMENT SURFACE.
- 4) SECURE WITH "LOCTITE" RETAINING COMPOUND #601 (GREEN) IN ADAPTER ONLY.

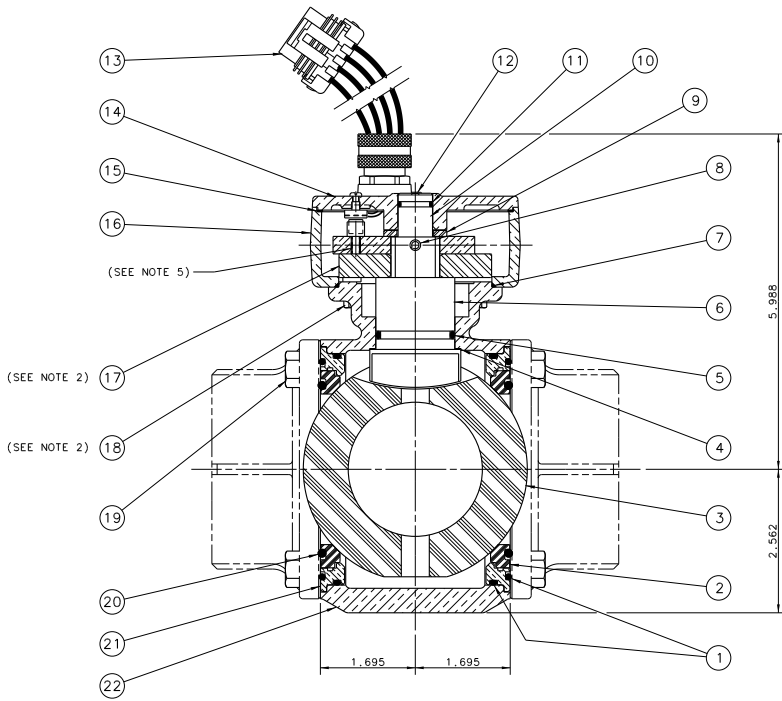
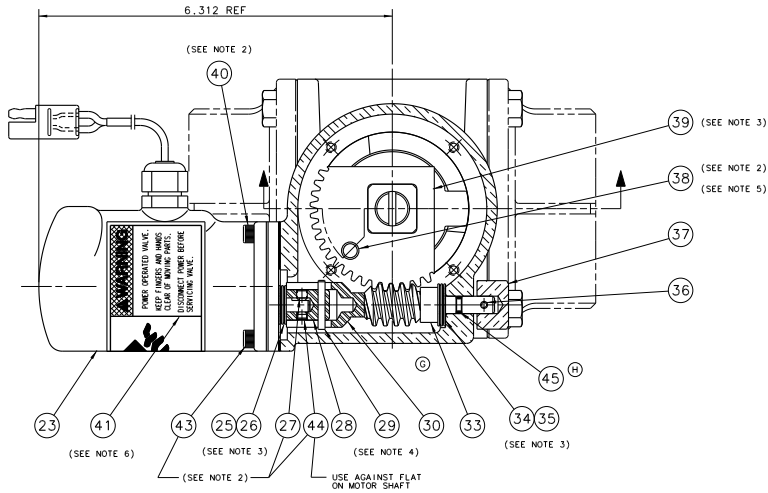

CAUTION: PRESS SENSORS COMPLETELY IN BY HAND BEFORE TORQUING SCREW (TORQUE NOT EXCEED 20 INCH-OUNCE)

GEARCASE POSITION
(VALVE SHOWN CLOSED)

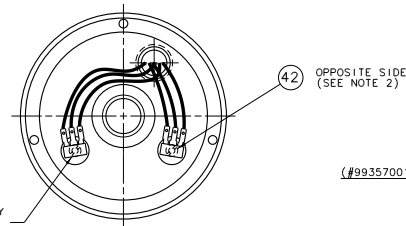
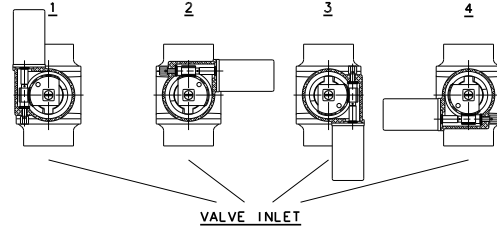

COVER DETAIL

- 6) BEFORE APPLYING DECAL SURFACE MUST BE CLEANED W/RUBBING ALCOHOL OR OTHER NON RESIDUE CLEANER. ALSO, PREMASK SHOULD NOT BE REMOVED FROM DECAL.
- 5) FILE THREADS FLAT WITH GEAR SEGMENT SURFACE.
- 4) PIN MUST BE IN CENTER OF SHAFT COUPLING.
- 3) APPLY GENERAL PURPOSE PETROLEUM BASE GREASE.
- 2) SECURE THREADS WITH "LOCTITE" ADHESIVE #242 (BLUE)

(E)	(B)	81205000	INFORMATION AND PARTS PACKET	1
(E)	(B)	81052000	SWITCH/INDICATOR MODULE	1
(E)	(B)	81196000	ELECTRIC VALVE CONTROL MODULE SUB-ASSEMBLY	1

ELECTRIC CONTROL MODULE

(H)	(D)	45	57380000	O-RING (AS 568-233) 0.178-10 X 0.070 C/S	1
(H)	(D)	44	63699000	SCREW-SET, SS (CUP POINT) #10-32 X 0.187-LG. SOC. HEX	1
(D)	(D)	43	64072000	SCREW-CAP (#300 SERIES S/S) #10-32 X 0.150-LG. SOC. HD	3
(D)	(D)	42	61177000	SCREW-PAN MACH #4-40 X 0.187 LG. (TYPE #302 SS)	2
(C)	(D)	41	25025000	DECAL-WARNING	1
(C)	(D)	40	61046000	SCREW-CAP (#300 SERIES S/S) #10-32 X 0.045-LG. SOC. HD	1
(C)	(D)	39	33784001	GEAR-SEGMENTAL	1
(C)	(D)	38	46051000	MAGNET # 0.31 X 0.67 #8-32 THD.	1
(C)	(D)	37	47652001	NUT-VALVE (3/4 HEX)	1
(A)	(D)	36	51248000	PIN-ROLL 7#-028-120-0825	1
(A)	(D)	35	17702000	BEARING-THRUST (5/16)	1
(A)	(D)	34	71516000	WASHER-THRUST (5/16)	2
(A)	(D)	33	63601001	SPACER	1
(G)	(D)	32			
(G)	(D)	31			
(G)	(D)	30	63935001	SHAFT-WORM	1
(G)	(D)	29	51071000	PIN-DRVLOC	1
(D)	(D)	28	20985001	COUPLING-FEMALE SHAFT	1
(D)	(D)	27	65201000	SCREW-SET, SS (CUP POINT) #10-32 X 0.045-LG. SOC. HD	1
(D)	(D)	26	17701000	BEARING-THRUST (1/4)	1
(D)	(D)	25	71515000	WASHER-THRUST (1/4)	2
(F)	(D)	24			
(D)	(D)	23	81119001	ASSEMBLY GEAR/MOTOR, 12-VDC (65.5:1 GEAR RATIO)	1
(D)	(D)	22	16995001	BODY-VALVE (2.5)	1
(C)	(D)	21	58894001	RETAINER SEAT (2.5)	2
(C)	(D)	20	57379000	O-RING (AS 568-233) 7#-040-187-0875	2
(C)	(D)	19	61173000	BOLT-HEX SS 0.375-18X 0.875	4
(A)	(D)	18	65111000	SCREW-MACH, SS #10-32 X 0.150-LG. SOC. HD	8
(A)	(D)	17	51815000	PLATE-STOP	1
(D)	(D)	16	23581001	CASE-GEAR (SMALL) N/S	1
(D)	(D)	15	33048000	GASKET-COVER	1
(D)	(D)	14	23519001	COVER-GEAR CASE (SMALL)	1
(D)	(D)	13	36782000	HARNES-CONTROL	1
(B)	(D)	12	64065000	SCREW-CAP (STML'S STL.) #8-32 X 0.370-LG. SOC. HD	3
(B)	(D)	11	57321000	O-RING (AS 568-233) 0.178-10 X 0.070 C/S	1
(B)	(D)	10	63771001	SHAFT-ACTUATOR (UPPER)	1
(B)	(D)	9	71514001	WASHER-THRUST	1
(B)	(D)	8	51235000	PIN-ROLL 7#-040-187-0875	1
(B)	(D)	7	57474000	O-RING (AS 568-038) 0.314 ID X 0.070 C/S	1
(B)	(D)	6	63775001	SHAFT-ACTUATOR (LOWER)	1
(B)	(D)	5	57396000	O-RING (AS 568-124) 2.27 ID X 0.103 C/S	1
(B)	(D)	4	71188000	WASHER-TEFLON	1
(B)	(D)	3	17313000	BALL-VALVE (2.5) ACETAL	1
(B)	(D)	2	63857000	SEAT-VALVE (2.5) U.H.W.P.E.	2
(B)	(D)	1	57436000	O-RING (AS 568-134) 3.737 ID X 0.103 C/S	4

NO.	PART NO.	PART NAME	REQ.
ELKHART BRASS MFG. CO., INC. ELKHART, IND. USA			
VALVE - FIRE APPARATUS WITH 2.5 BALL			
NO.	PART NO.	PART NAME	REQ.
1	2925-E	VALVE - FIRE APPARATUS WITH 2.5 BALL	1

REV.	BY	DATE	DESCRIPTION
1	WJ	01/01/00	ISSUED FOR PRODUCTION
2	WJ	01/01/00	REVISIONS

REV.	BY	DATE	DESCRIPTION
1	WJ	01/01/00	ISSUED FOR PRODUCTION
2	WJ	01/01/00	REVISIONS

REV.	BY	DATE	DESCRIPTION
1	WJ	01/01/00	ISSUED FOR PRODUCTION
2	WJ	01/01/00	REVISIONS

PART # 02925100 2925-E (REV. 1)