



FLUSH INLET

NPT OUTLET SIZE (Inches)	INLETS				BODY TYPE	Individual Drop Clapper	MEASUREMENTS (Inches)										CERT		AVAILABLE ESCUTCHEON LETTERING		MATERIAL/ FINISH			Weight (Lbs.)	MODEL	FIGURE		
	NHT (F)		STORZ				Straight	Inverted 90°	A	B	C	D	E	F	G	H	J	FM Approved	U.L. Listed	Auto-Spkr	Standpipe	Standpipe and Auto-Spkr	BRASS					
	1.5"	2.5"	4"	5"																			Polished Brass				Polished Chrome	Elk-O-Lite®
	1	1	2	3																			1				1	1
1½	•																	s				s	1¼	141	1			
2½	•																	o	s			s	o	8⅞	151-2.5	1		
	•													7	10½			s	o			s	o	11	161-2.5	2		
3	•																	o	s			s	o	8⅞	151-3	1		
	•													7	10½			s	o			s	o	11¼	161-3	2		
4			•												12			s	o			s		6⅞	171	1		
				•											12			s	o			s		10⅞	171	1		
		•					•	11	7½	5	6⅞	3 ²⁵ / ₃₂	3 ⁷ / ₃₂			13 ⁷ / ₁₆	•	•	s	o	o	s	o	23	166-4-ST**	3		
		•					•	11½	7½	5	6⅞	3 ¹⁹ / ₃₂	3 ³ / ₈	3 ⁷ / ₁₆	5 ⁵ / ₈	13 ⁷ / ₁₆	•		s	o	o	s	o	26¼	166-4-90**	4		
		•					•	11 ¹¹ / ₁₆	7½	5	6¼	3 ³ / ₄	3 ³ / ₈	4 ⁷ / ₁₆	7 ¹ / ₁₆	13 ⁷ / ₁₆			s	o	o	s	o	31	166-4-INV**	5		
6			•												12			s	o			s		7¼	171	1		
				•											12			s	o			s		10¼	171	1		
		•					•	11½	7½	7½	8	3 ³ / ₄	3 ³ / ₈			13 ⁷ / ₁₆	•		s	o	o	s	o	30¾	166-6-ST**	3		
		•					•	12	7 ⁷ / ₈	7½	7¾	4	4 ⁷ / ₃₂	3 ⁷ / ₁₆	6 ⁵ / ₃₂	13 ⁷ / ₁₆	•		s	o	o	s	o	34 ³ / ₈	166-6-90**	4		
			•				•	17 ⁷ / ₁₆	6 ⁷ / ₈	7 ³ / ₈	6 ¹¹ / ₁₆	3 ³ / ₈	4 ¹ / ₁₆		4 ³ / ₁₆				s		s	o		68	167-W-ST***	8		
			•				•	17¼	6 ⁷ / ₈	7 ⁷ / ₈	8 ⁷ / ₁₆	4 ¹⁵ / ₃₂	4	3 ¹⁵ / ₁₆	5 ¹⁵ / ₁₆	20¼			s		s	o		68	167-W-90***	6		
			•				•	17¾	6 ⁷ / ₈	7 ⁷ / ₈	8 ⁷ / ₁₆	4 ¹⁵ / ₃₂	4	3 ¹⁵ / ₁₆	5 ¹⁵ / ₁₆	20¼			s		s	o		68	167-W-INV***	7		

Key s = standard o = option
 * Straight connection adapter.
 ** Can order body separately.
 *** Can order parts (with or without clappers) separately.

ADDITIONAL INFORMATION

- Bodies rated for 175 psi (12.1 bar).
- Each 2½" NHT inlet has a rated flow of 250 gpm (946 lpm).
- Supplied with plug(s) and chain(s).

THREADS

Unless otherwise noted, all hose threads are NHT. See index T-13 for available optional threads.

OTHER PRODUCTS

- See page 13-16 for Flush 4-Way Inlet Connections.
- 2½" nipple required for all 166 and 167-W models. Elkhart Brass does not supply.
- On the 166, the body is roughed in during construction; escutcheon and nipple assemblies are installed after construction. Elkhart Brass personnel can help with construction installation information.

FIGURE 1

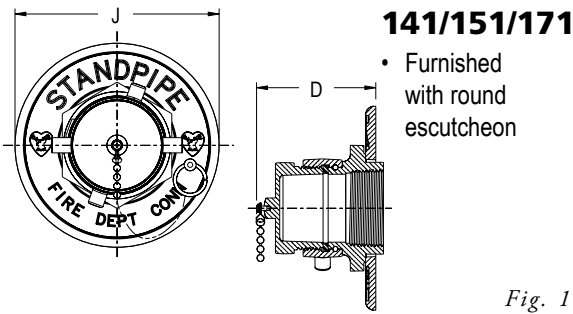

FIGURE 2

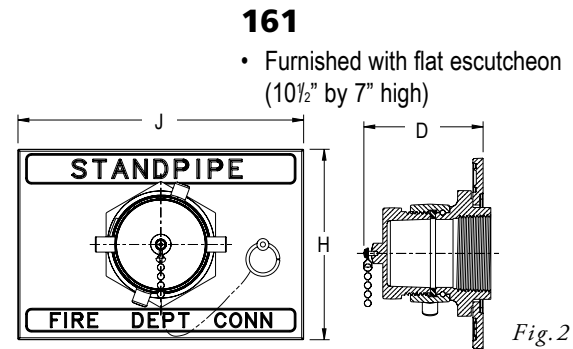

FIGURE 3

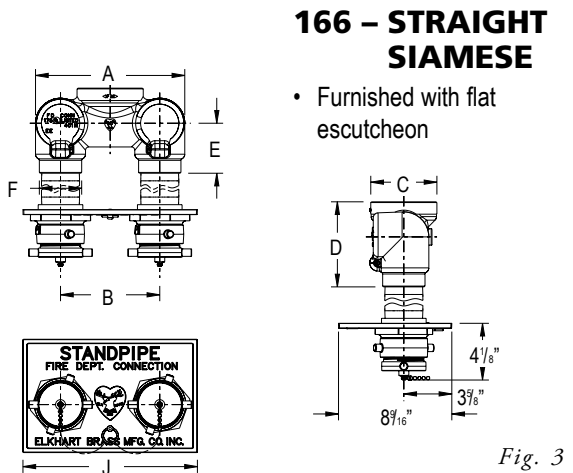

FIGURE 4

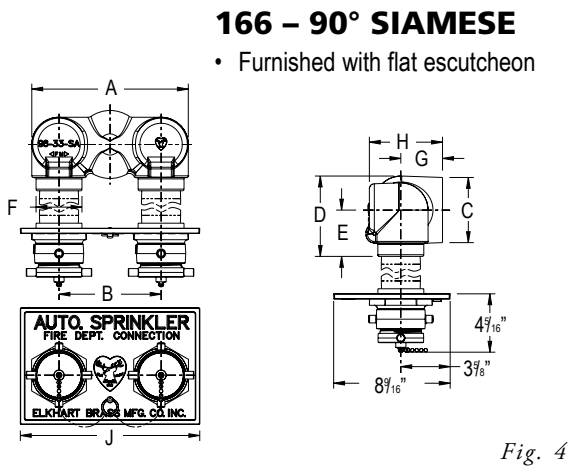

FIGURE 5

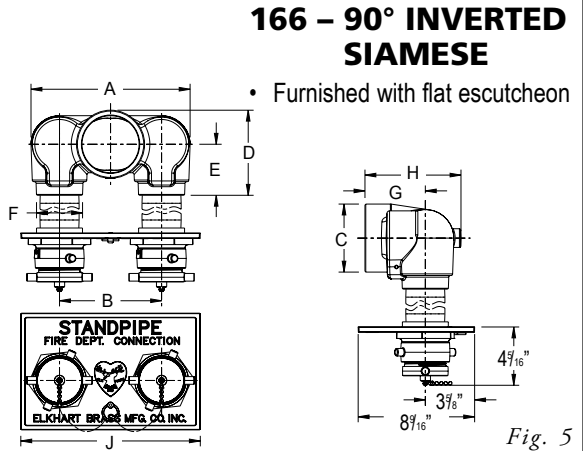

FIGURE 6

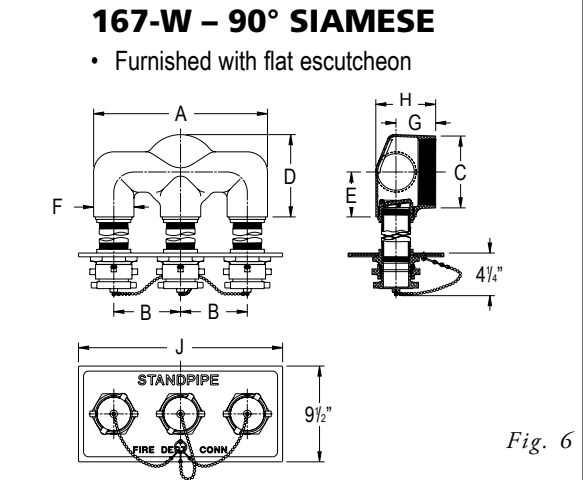

FIGURE 7

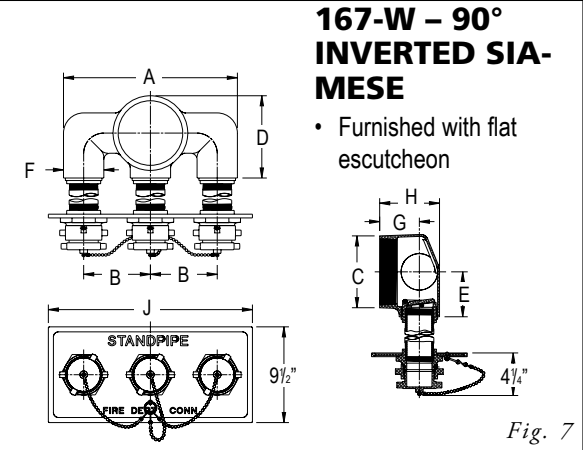

FIGURE 8

