



# Ordering Guide

## Select a monitor

\_\_\_\_\_ 7600X2 Magnum 5000 GPM (20,000 LPM)

## Select inlet option

\_\_\_\_\_ 6.0" 150# Flange

## Select outlet option

\_\_\_\_\_ 6.0" NHT M



## Nozzle options

\_\_\_\_\_ CM-3000E (D) – 6.0" inlet fixed flow nozzle (includes integrated stream shaper)

\_\_\_\_\_ CM-5000E (D) – 6.0" inlet fixed flow nozzle (includes integrated stream shaper)

\_\_\_\_\_ CM-3000EX (D) – 6.0" inlet fixed flow extended reach nozzle (includes integrated stream shaper)

## Select input controllers

\_\_\_\_\_ 7010X2 Panel Mount Controller

\_\_\_\_\_ 7015X2 Wireless Handheld Package (must select FCC or CE version below)

\_\_\_\_\_ FCC application (915 MHz) \_\_\_\_\_ CE application (868 MHz)

\_\_\_\_\_ 7030X2 Proportional Joystick

## Accessory options

\_\_\_\_\_ 7051X2 Position Display (provides horizontal and vertical monitor position via LED display)

## Recommended Water Valve – 6.0" or 8.0" Butterfly Valve

Refer to the Unibody Configurator at [www.elkhartbrass.com/downloads/tools](http://www.elkhartbrass.com/downloads/tools) to select the appropriate valve and endcap package. The EB series of valves matched with the E14X/E16X Electric Actuator all have the capability of being controlled from any of the EXM2 input controllers listed above.





# CANbus Harness Selector Guide

## EXM2 MONITOR

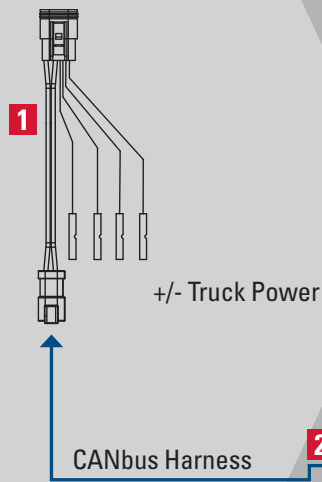

## EXM2 COMPONENT

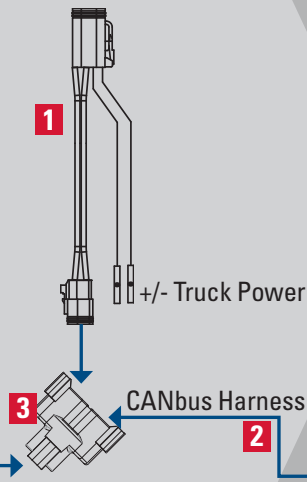

## EXM2 COMPONENT

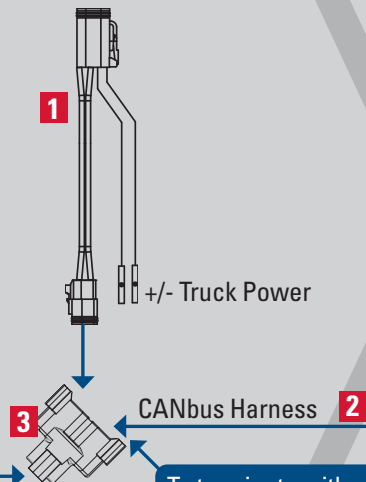

## UNIBODY VALVE

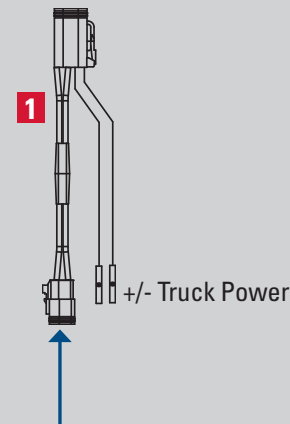

To terminate without a Unibody valve, insert the CAN Termination Plug here. This represents the end of the CANbus network.

Each EXM2 monitor and component comes with a harness/pigtail (1) with wire leads for +/- truck power and wire leads for CANbus. The EXM2 monitor harness is equipped with two sets of truck power leads.

EXM2 components include Panelmount Controller, Joystick, Wireless Handheld Gateway Module and Position Display.

To construct the system, select a CANbus harness (2) by determining the distance between each component (select quantity and length below). Add a CAN Splitter (3) for each location where the CANbus will continue to the next component. The example above will require three (3) CANbus harnesses and two (2) CAN Splitters.

The monitor should be at one end of the CANbus network and if using a Unibody Valve with the system, the valve should be installed at the other end of the CANbus network as shown. For systems where the valve is NOT at the end of the network, refer to the APEX VALVE CONTROLLER Installation Manual at [www.elkhartbrass.com/products/apparatus-valves/APEX/manuals](http://www.elkhartbrass.com/products/apparatus-valves/APEX/manuals).

The CANbus system requires termination at each ends of the network. Each EXM2 monitor and Unibody valve includes integrated termination. If the network is constructed as shown with monitor and valve on each end, no further termination is required. If a Unibody Valve is not part of the system, the last component opposite the monitor must be terminated using a CAN Splitter and CAN Termination Plug (select below).

\_\_\_\_\_ 37543002 - 2' CAN extension harness

\_\_\_\_\_ 37543010 - 10' CAN extension harness

\_\_\_\_\_ 37543015 - 15' CAN extension harness

\_\_\_\_\_ 37543020 - 20' CAN extension harness

\_\_\_\_\_ 37543030 - 30' CAN extension harness

\_\_\_\_\_ 37543040 - 40' CAN extension harness

\_\_\_\_\_ 24196000 - CAN Splitter

\_\_\_\_\_ 24197000 - CAN Termination Plug

1-574-295-8330  
[www.elkhartbrass.com](http://www.elkhartbrass.com)





# Components

## Panel Mount Controller 7010X2

Designed to be mounted on a panel, the controller is hardwired directly to the monitor via CANbus. Compatible with 12 or 24VDC systems and rated to IP67.

Panel Mount Controller



## Wireless Handheld Controller/Gateway 7015X2

The IP67 rated wireless remote control includes everything needed to operate a monitor, nozzle and optional Unibody valve from a safe location. The docking station with built-in induction charging system eliminates the need for replaceable batteries. The wireless controller comes pre-configured to communicate via RF to the Gateway Module. The module, with an external antenna, can then be mounted in a location convenient to the apparatus builder. The Gateway connects via CANbus harnesses directly to the monitor.

Wireless Handheld Controller & Gateway



## Joystick Controller 7030X2

The joystick controller is designed to be surface mounted in the vehicle cab, providing convenient and intuitive control of the monitor. Containing all of the EXM2 monitor controls, the joystick utilizes proportional speed control for precise positioning of the water stream. Operate a Unibody Valve using the joystick trigger or the OPEN/ CLOSE buttons on the mounting plate. Integrating CANbus within the joystick design eliminates the need for an external module, simplifying installation and programming.

Joystick Controller



## Position Display 7051X2

The Position Display provides instant feedback to the operator on the monitor's current position utilizing the signal from the monitor's integrated position sensors.

Position Display

